

Sensor Signal Amplifier Type 7b (Miniature Patrone)

integrated rotor coil

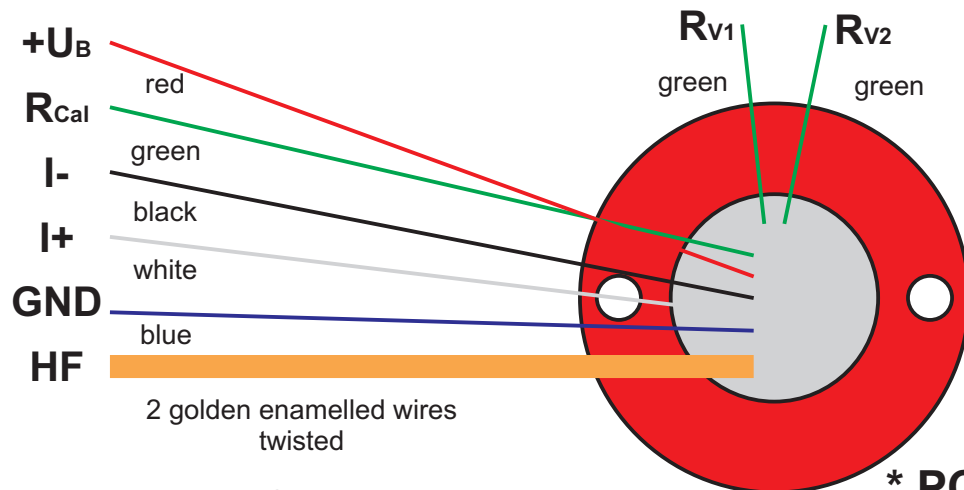
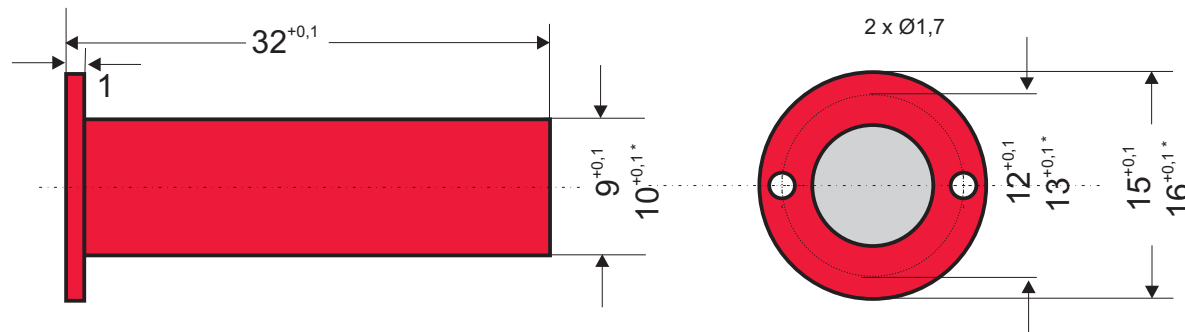
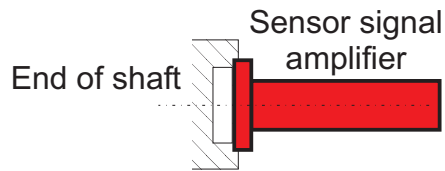

Gewicht: 5 g
Trägheitsmoment: 1,5E-8 kgm²

* PCM-Version

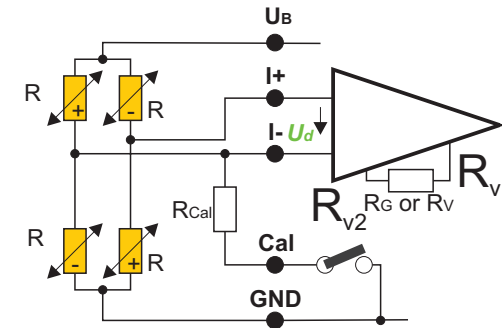

1 Channel FM/PCM Transmitter

For strain gage, PT100, Thermocouple

Sensitivity: 0,02 mV/V to 20 mV/V

Bandwidth: 0 (10) Hz to 50 kHz

Strain gage bridge supply: 6 V (3,3 V*)

Strain gage bridge resistance: 1000 Ω

Transmission: inductive sensortelemetry FM, PCM

Integrated filter

Resolution: 14 Bits, 16 Bits*

Zero point drift: 0,02, (0,01, 0,003* option)

Remote shunt calibration

Environmental temperature range: -25 to +85°C (125°C, 160°C)

Max load: 150 000 g (depending on fixing)

Type: SV_7b_<bandwidth>_<accuracy>_<temp>_<mod>

1 kHz	0,02	85	FM
10 kHz	0,01	125	PCM16
40 kHz	0,003	160	