

Standard Encoder EE 63 EE 71

Optical incremental shaft encoders with inch mounting dimensions available with **Sine/Cosine Signals**

Centering diameter 31,75 mm = 1 1/4 Zoll
 Shaft diameter 9,52 mm = 3/8 Zoll
 EE 63 with servoflange, EE 71 with square flange

Resolution

Resolution (Pulses/Revolution):

1 - 6000	7000	7200	7500
8000	8192	9000	9144
10000			

Every other resolution up to 500 000 on request

Type explanation

EE 63-6-5000-05-D-RM10

Encoder type	Incremental
Flange diameter	ø 63 mm
Case diameter	ø 58 mm
Number of channels	3 = A + B + M 6 = AA + BB + MM
Resolutions	xxxx = Impulse pro Umdrehung
Supply voltage	05 = 5 VDC ± 5% 30 = 10..30 VDC
Output driver	D-RS422 P S
Position of connection	R S
Connector	C07 = 7 pins Binder C12 = 12 pins M23 M10 = 10 pins MIL
Shaft diameter	ø 10 mm

Technical data

Mechanical data

Rotational speed	? 12000 min ⁻¹
Torque	? 0,3 Ncm
Breakaway torque	? 0,1 Ncm
shaft loading	? 20 N radial ? 10 N axial
Angular acceleration	? 10 ⁴ rad/sec ²
Weight	? 0,6 kg

Environmental conditions

Vibration	200 ms ⁻² (20 ... 2000 Hz)
Shock	2000 ms ⁻² (11 ms)
Operating temperature	0 .. +80°C standard -20 .. +110°C optional -42 .. +110°C optional
Atmospheric humidity	? 85% r.h.
Protection class	IP 65 (DIN 40050/IEC 144) IP 68 (optional)

Electrical data

Scanning type	Optical, without contact
Transmitter, infrared	LED
Receiver	Photo-Transistor
Measurement accuracy	± 1' standard ± 10" optional
Supply voltage	V _{cc} = 5 VDC ±5% V _{cc} = 10...30 VDC
Power consumption	200 mA max
Output frequency	? 300 kHz (Output D) ? 160 kHz (Output P, S)
Signal level	High > V _{cc} -2 V (Output D, P) Low < 0,5 V (Output D, P) Analog 1 V _{ss} (Output S)
Load capacity of the outputs	20 mA

Cable 3 channels

Wire colour	Signal
Brown	+Vcc
Grey	0 V GND
Green	Signal A
White	Signal B
Yellow	Signal M
Shield	N.C.

Cable 6 channels

Wire colour	Signal
Brown 0,5 mm ²	+Vcc
Blue	+Vcc Sense ¹⁾
White 0,5 mm ²	0 V GND
White	0 V Sense
Brown	Signal A+
Green	Signal A-
Grey	Signal B+
Pink	Signal B-
Red	Signal M+
Black	Signal M-
Shield	N.C.

1) nur bei Vcc = 5 VDC TTL

Connector 7 pins Binder

Connection	Signal
Pin 1	0 V GND
Pin 2	N.C.
Pin 3	Signal A
Pin 4	Signal B
Pin 5	+Vcc
Pin 6	Signal M
Pin 7	Shield

Connector 12 pins M23

Connection	Signal
Pin 1	Signal B- ¹⁾
Pin 2	+Vcc Sense ²⁾
Pin 3	Signal M+
Pin 4	Signal M- ¹⁾
Pin 5	Signal A+
Pin 6	Signal A- ¹⁾
Pin 7	N.C.
Pin 8	Signal B+
Pin 9	Shield
Pin 10	0 V GND
Pin 11	0 V Sense
Pin 12	+Vcc

1) nur bei 6 Ausgangskanälen

2) nur bei Vcc = 5 VDC TTL

Connector 10 pins MIL

Connection	Signal
Pin A	Signal B+
Pin B	Signal A+
Pin C	Signal M+
Pin D	+Vcc
Pin E	+Vcc Sense
Pin F	0 V GND
Pin G	Shield
Pin H	Signal B- ¹⁾
Pin I	Signal A- ¹⁾
Pin J	Signal M- ¹⁾

1) nur bei 6 Ausgangskanälen

Output driver

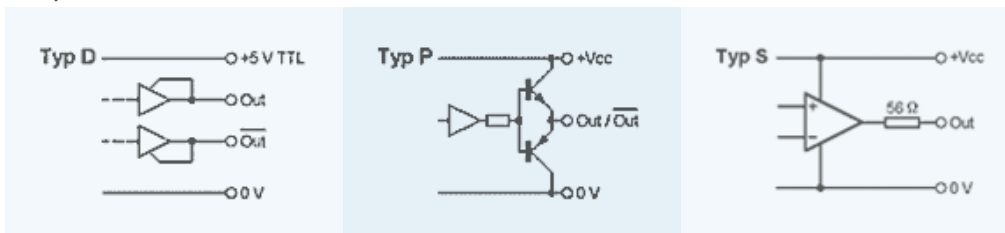

Outline drawing

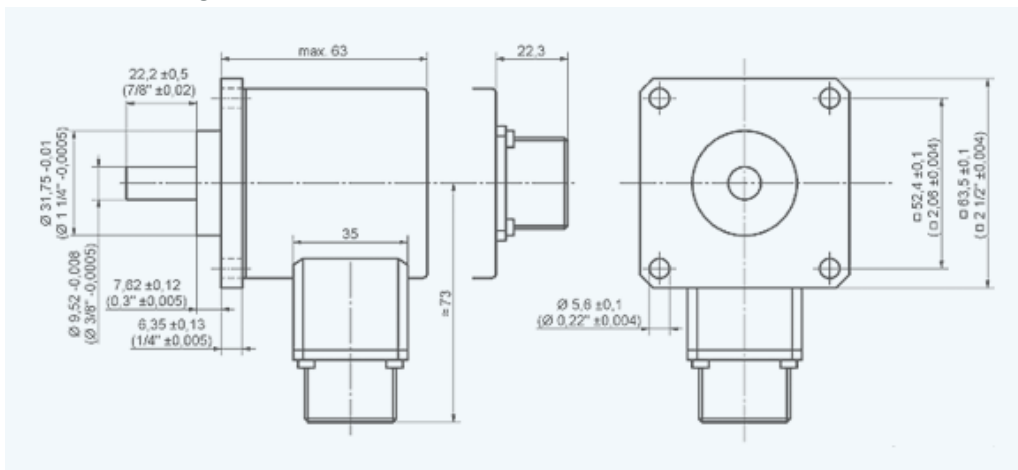

Version E 518-207 · Subject to change

INDUcoder® · INDUcoder Messtechnik GmbH, Kaiserstraße 316, 47178 Duisburg, Deutschland
 Tel: (0203) 57047-0, Fax: (0203) 57047-20, E-Mail: info@inducoder.de, Internet:
www.inducoder.de