



## Standard No Shaft Encoder EDH 75/EDH 751

Optical incremental encoder with hollow shaft

### Resolution

#### Resolution (Pulses/Revolution):

1	4	10	12
50	100	128	157
180	200	250	256
350	360	375	400
500	512	600	720
1000	1024	1250	1500
1800	2000	2048	2160
2500	3600	4000	4096
4500	5000	5400	6000
7200	9000	10000	18000

Every other resolution up to 900 000 on request

### Type explanation

#### EDH 75-6-2500-05-D-SC12/Ø15

Encoder type	Incremental
Hollow shaft	Yes
Flange diameter	ø 75 mm
Case diameter	ø 75 mm
Number of channels	3 = A + B + M 6 = AA + BB + MM
Resolutions	xxxx = Impulse pro Umdrehung
Supply voltage	05 = 5 VDC ± 5% 30 = 10..30 VDC
Output driver	D-RS422 P S
Position of connection	S
Connector	C07 = 7 pins Binder C12 = 12 pins M23
Shaft diameter	ø 15 mm

## Technical data

### Mechanical data

Rotational speed	? 8000 min <sup>-1</sup>
Torque	? 1 Ncm
Breakaway torque	? 3 Ncm
Loading of bearings	20 N radial ? 10 N axial
Angular acceleration	? 10 <sup>4</sup> rad/sec <sup>2</sup>
Weight	? 0,7 kg

### Environmental conditions

Vibration	200 ms <sup>-2</sup> (20 ... 2000 Hz)
Shock	2000 ms <sup>-2</sup> (11 ms)
Operating temperature	0 .. +80°C standard -20 .. +110°C optional -42 .. +110°C optional
Atmospheric humidity	? 85% r.h.
Protection class	IP 54 (DIN 40050/IEC 144) IP 65 (DIN 40050/IEC 144)

### Electrical data

Scanning type	Optical, without contact
Transmitter, infrared	LED
Receiver	Photo-Transistor
Measurement accuracy	± 1' standard ± 5" optional
Supply voltage	V <sub>cc</sub> = 5 VDC ±5% V <sub>cc</sub> = 10...30 VDC
Power consumption	200 mA max.
Output frequency	? 300 kHz (Output D) ? 160 kHz (Output P, S)
Signal level	High > V <sub>cc</sub> -2 V (Output D, P) Low < 0,5 V (Output D, P) Analog 1 V <sub>ss</sub> (Output S)
Load capacity of the outputs	20 mA

### Cable 3 channels

Wire colour	Signal
Brown	+ Vcc
Grey	0 V GND
Green	Signal A
White	Signal B
Yellow	Signal M
Shield	N.C.

### Cable 6 channels

Wire colour	Signal
Brown 0,5 mm <sup>2</sup>	+Vcc
Blue	+Vcc Sense <sup>1)</sup>
White 0,5 mm <sup>2</sup>	0 V GND
White	0 V Sense
Brown	Signal A+
Green	Signal A-
Grey	Signal B+
Pink	Signal B-
Red	Signal M+
Black	Signal M-
Shield	N.C.

1) nur bei Vcc = 5 VDC TTL

### Connector 7 pins Binder

Connection	Signal
Pin 1	0 V GND
Pin 2	N.C.
Pin 3	Signal A
Pin 4	Signal B
Pin 5	+Vcc
Pin 6	Signal M
Pin 7	Shield

### Connector 12 pins M23

Connection	Signal
Pin 1	Signal B- <sup>1)</sup>
Pin 2	+Vcc Sense <sup>2)</sup>
Pin 3	Signal M+
Pin 4	Signal M- <sup>1)</sup>
Pin 5	Signal A+
Pin 6	Signal A- <sup>1)</sup>
Pin 7	N.C.
Pin 8	Signal B+
Pin 9	Shield
Pin 10	0 V GND
Pin 11	0 V Sense
Pin 12	+Vcc

1) nur bei 6 Ausgangskanälen

2) nur bei Vcc = 5 VDC TTL

### Output driver

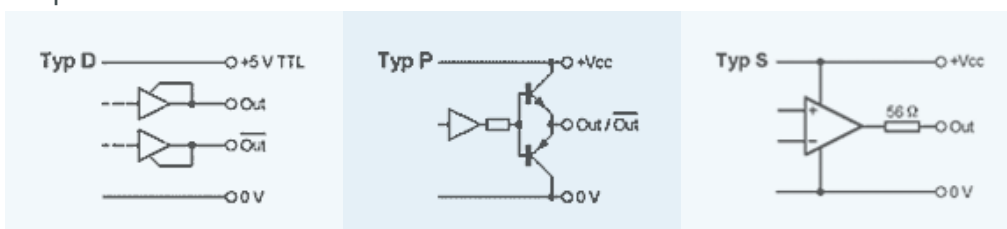

## Outline drawing

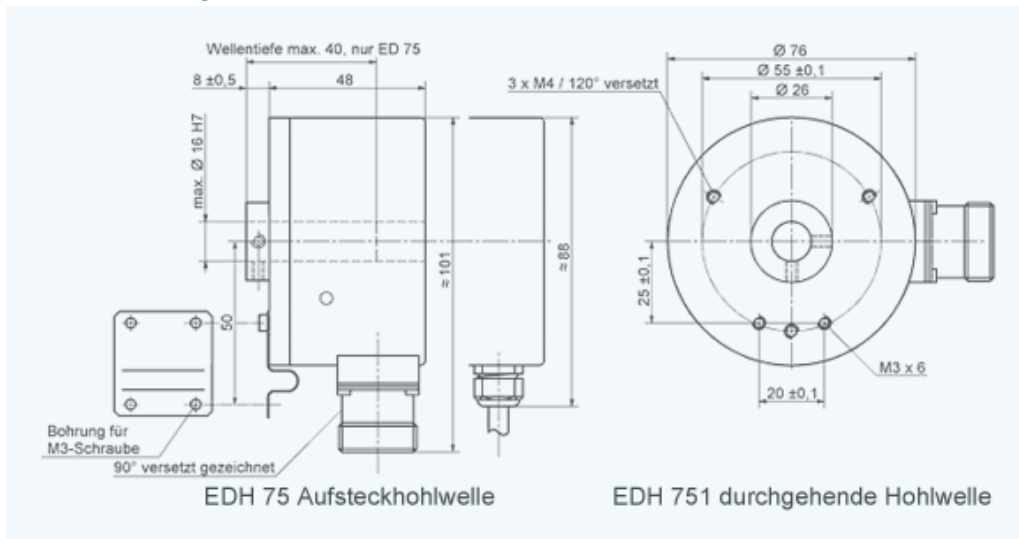

Version E 608-209 · Subject to change

INDUcoder® · INDUcoder Messtechnik GmbH, Kaiserstraße 316, 47178 Duisburg, Deutschland  
Tel: (0203) 57047-0, Fax: (0203) 57047-20, E-Mail: [info@inducoder.de](mailto:info@inducoder.de), Internet:  
[www.inducoder.de](http://www.inducoder.de)