

# DIGITAL TENSION CONTROLLER

MODEL **TC-3A** PAT.

*It's because of our experience  
in the industry that we can provide you  
with a user-friendly Digital Tension Controller.*



## ■ Introduction

The TC-3A operates as a tension controller, and it also has a pre-set counter.

The tension output can be preset to the counter's value and the TC-3A outputs voltage in proportion to the counting value so that it maintains continuous tension control between the empty bobbin tension and full bobbin tension.

In combination with a tension control device, ie powder clutch, you can keep continuous control of the tension in coiling and uncoiling, without the use of a dancer roller.

## ■ Special features

- When the empty and full bobbin tension outputs are preset to the counter's value, the tension output will change from one to another in proportion to the counter's value so that tension control can be kept smooth and continuous.  
Also before operating, you can see the tension for each counter's value and anytime while operating, you can check the counting value and the tension.
- This can be used as a preset counter with an output relay, that actuates on the preset value or zero reading.
- Both power output and voltage output are provided.  
The power output can directly control a powder clutch, etc, while the voltage output can control devices such as a voltage regulator.
- An optional tension setter and calculator can be connected to the TC-3A in order to compensate for inertia during starting and stopping of the machine.
- The TC-3A has an auxiliary input pin, which can receive positive and negative signals from the dancer roll. The TC-3A will mix the signal with the counter and give the correct output voltage.
- The number of digits on the counter display can be changed easily.
- The power supply of DC 15V, 50mA for sensor and DC  $\pm 15V$ , 10mA auxiliary power supply are built in.
- The count value can be retained in memory with a built-in battery.
- Unnecessary zeros are suppressed so as to avoid confusion for the operator.
- Light and compact.

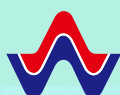

**WADECO CO.,LTD.**

# DIGITAL TENSION CONTROLLER

## ■ Specifications

**Model :** TC-3A-6 (6 digit) — Standard  
 TC-3A-5 (5 digit)  
 TC-3A-4 (4 digit)

**Control power supply :** AC 200V ± 10%, 50/60Hz

**Power consumption :** 9VA

Except for the consumption of sensor and auxiliary power supply.

**Main power supply :** Max. AC 30V, 50/60Hz

**Power output :** DC 0 ~ 24V, 4A

**Voltage output :** DC 0 ~ 10V, 10mA

**Counter :** Changing-over of 4, 5, 6 digit, Red LED.

**Output meter :** Analogue voltmeter

Full scale DC 10V ~ DC 24V (Adjustable)

**Counting :** Increasing or decreasing

With increasing counting method :

The counter keeps counting after the preset value is reached and after it comes to the maximum number it will begin from zero again.

With decreasing counting method :

After reaching zero, it will stop counting.

**Maximum counting speed :**

100CPS, contact or non-contact input. Switching ratio : 1/1

**Counting input :** To be counted when ON → OFF, "L" → "H"

H : over 5V, L : Under 3V.

**Auxiliary input :** ± 10VDC



**Output contact :** AC 250V, 3A (cosφ = 1), 1C

Keep or oneshot (500msec.)

With increasing counting, the output relay will be actuated at or over the preset value.

With decreasing counting, the output relay will be actuated at zero with oneshot signal or one continuous signal.

**Power supply for sensor :** DC 15V, 50mA

**Auxiliary power supply :** DC ± 15V, 10mA

**Memory function :** Over 500 hours.

**Ambient temperature :** -10°C ~ +50°C

**Finish color :** Black

**Weight :** 2.2kg

## ■ Preset and adjustment

### 1. Configuration of digital counter

Select a configuration of either 4, 5 or 6 digits.

The selection must cover the counting value from empty to full bobbin for the thinnest wire.

After configuration only the first 4 of the selected digits may be converted to an analogue output.

As a result, if the counting value is too small in proportion to the configured number of digits you may not obtain enough output voltage.

When the empty tension dial is set at "0", and the full tension dial is set at its maximum, the range of the counting values to obtain the maximum output on a full tension setting is as follows.

4-digit : 40 ~ 9999 5-digit : 400 ~ 99999

6-digit : 4000 ~ 999999

The number of digits is configured in the factory according to the users requirements.

On site configuration of the counter however may be done as follows:

- ① Loosen the securing screws of the green connector and remove the connector (14).
- ② Remove the back cover.
- ③ Remove the top cover.
- ④ Locate the bank of counter configuration pins (CC).
- ⑤ Connect the pins according to the following diagram.

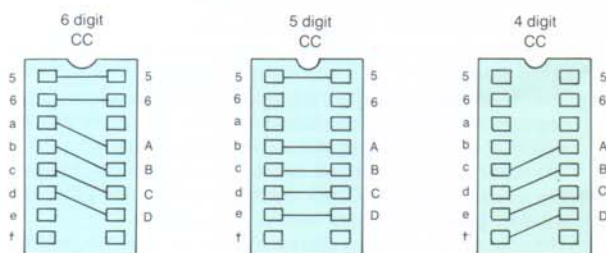

- ⑥ Replace the top cover and the back cover then insert the green connector (14) and fasten the two screws. Be careful not to insert the connector upside down.

### 2. Change over output meter

(Factory connected to power output voltage.)

In order to indicate the power output voltage (The voltage between terminals 5 and 6) the output meter connector has been factory connected to pin J1 on the lower printed circuit board.

However if you would like the voltage output (The voltage between connector pins 17 and 18) indicated on the output meter, follow the procedure below.

- ① Remove the green connector (14) as before.
- ② Remove the back cover.
- ③ Partially pull out the lower printed circuit board and remove the connector socket from pin J1.
- ④ Connect it to pin J5 on the upper printed circuit board.
- ⑤ Replace the back cover and insert the green connector (14) as before.

### 3. Adjusting the full scale of output meter

(It has been factory adjusted to show full scale (10) to full output) (when AC 20V is applied to main power supply terminals.)

The output meter is a DC 10 Volt full scale voltmeter. The full scale of the voltmeter can be varied from 10 to 24 Volt DC with the voltmeter full scale rheostat.

When the output meter is connected to the voltage output (pin J5) it will indicate the voltage output regardless of the voltmeter full scale rheostat's position.

Set full scale of the output meter according to the main power supply voltage as below.

- ① After completing external wiring turn on the control and the main power supply.
- ② Set the empty tension dial (5) at maximum (Turned fully clockwise).
- ③ Adjust the voltmeter full scale rheostat (16) so that the output meter indicates 10.

### 4. Counter gain adjustment :

(It is factory adjusted on the counting value of 100,000.)

- ① Set the counting number to the digital switch (8), which measures from the empty bobbin to the full bobbin, by winding the thickest wire to get the minimum count number of a full bobbin.
- ② Press the load button (6). The counter (1) will automatically show the number that was set by the digital switch (8).
- ③ Turn the empty bobbin tension dial (5) counter clockwise to the position "0".
- ④ Turn the full bobbin tension dial (4) clockwise to the position "10".
- ⑤ The value of the output meter will be increased while the counting gain main adjusting rheostat (9) or fine rheostat (10) turned clockwise. And stop turning just when the output meter indicates 10.

## Operation

V<sub>f</sub> : Full bobbin tension (adjustable)  
 V<sub>0</sub> : Empty bobbin tension (adjustable)  
 C<sub>f</sub> : Maximum number of turns or length of full bobbin. (adjustable)

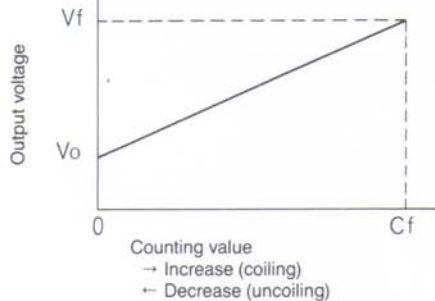

1. Push the reset button ⑦ and counter ① will automatically indicate "0".
2. While reading the output meter ③, set the empty bobbin tension (V<sub>0</sub>) with the empty bobbin tension dial ⑤.  
The empty bobbin tension should be set prior to setting the full bobbin tension.
3. Set the digital switch ⑧ to the maximum number of turns or length (C<sub>f</sub>) to be processed.
4. Press the load button ⑥, the counter ① will automatically indicate the value (C<sub>f</sub>) entered from the digital switch.
5. While reading the output meter ③, set the full bobbin tension (V<sub>f</sub>) with full bobbin tension dial ④.
6. In the coiling process, start the machine after pushing the reset button ⑦. In the uncoiling process, start the machine after pressing the load button ⑥.

## Connection

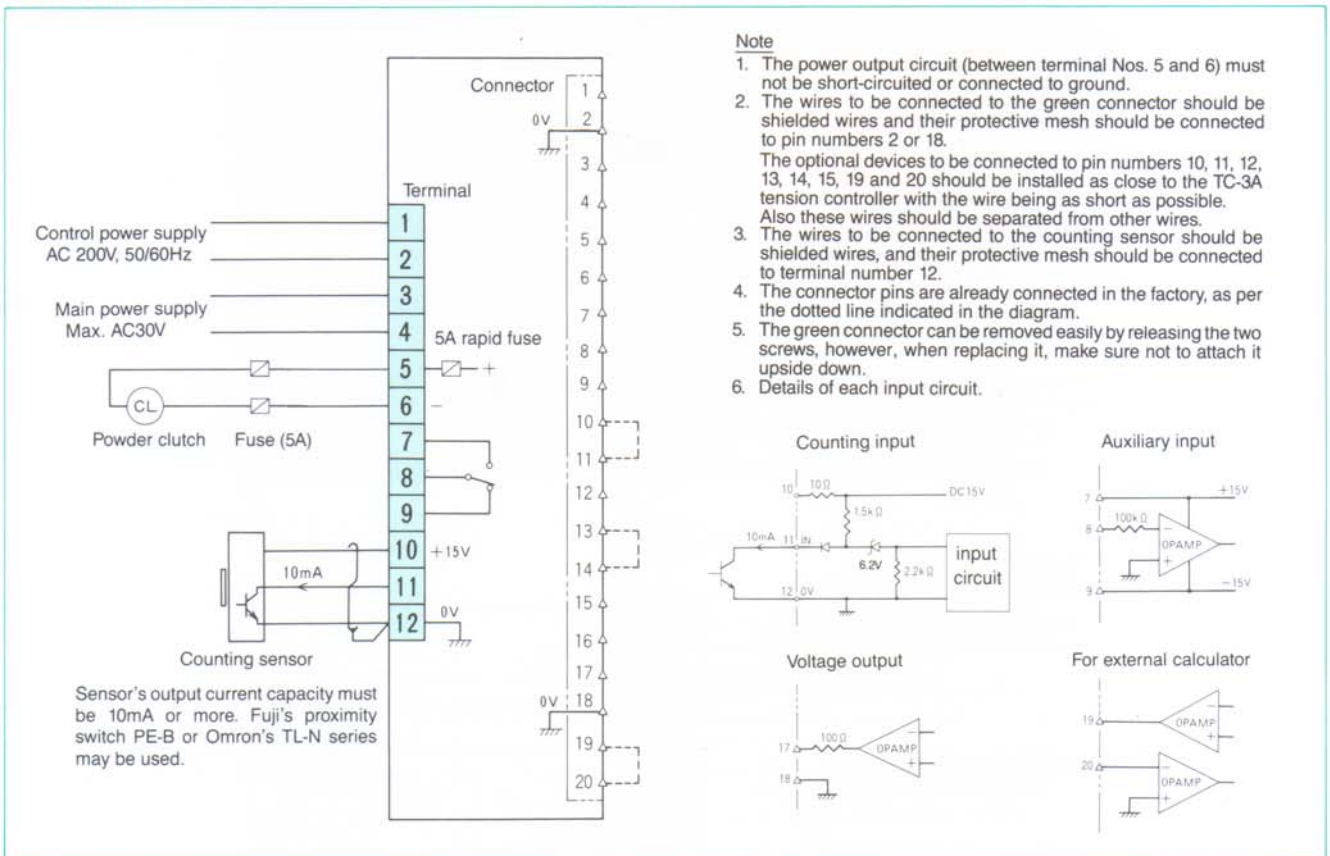

## Terminal description

Nos.	Name	Description	Nos.	Name	Description		
Terminal	1-2	Control power supply	To be connected to a supply of AC 200V.	Connector pin	5-6	Keep and single shot change over	Connecting 5 and 6 makes the output relay keep and opening it makes a single shot.
	3-4	Main power supply	To be connected to a maximum of AC 30V main power supply.		7	Auxiliary power supply ⊕	DC +15V, Max. 10mA
	5-6	Power output	DC load such as powder clutch can be connected with max. DC 24V, 4A.		8	Auxiliary input signal pin	Used for auxiliary input
	7-8-9	Output contact	This can be actuated at the preset value for the increasing process or at "0" for the decreasing process.		9	Auxiliary power supply ⊖	DC -15V, Max. 10mA
	10-12	Power supply for sensor	The DC 15V power supply for sensor, with up to a max. of 50mA.		10-11-12	Pins for external full bobbin tension dial	When an external full bobbin tension is required, remove the jumper between pin numbers 10 and 11 and connect the option.
	11	Counting input	The output of the counting sensor is connected.		13-14-15	Pins for external empty bobbin tension dial	When an external empty bobbin tension is required, remove the jumper between pin numbers 13 and 14 and connect the option.
Connector pin	1	Increasing decreasing change over	Opening 1 and 2 increases the count, and connecting decreases count.	17	Voltage output pin	Output voltage 0-10VDC, 10mA, useable for controlling voltage regulator.	
	2	Common pin	"0" V	18	Common pin	"0" V	
	3	Load pin	Connecting 3 and 2 loads the preset value into the counter.	19-20	Pins for external calculator	Optional external calculator can be connected. When connected, remove the jumper between pin numbers 19 and 20.	
	4	Reset pin	Connecting 4 and 2 resets the counter.				

**Dimensions**

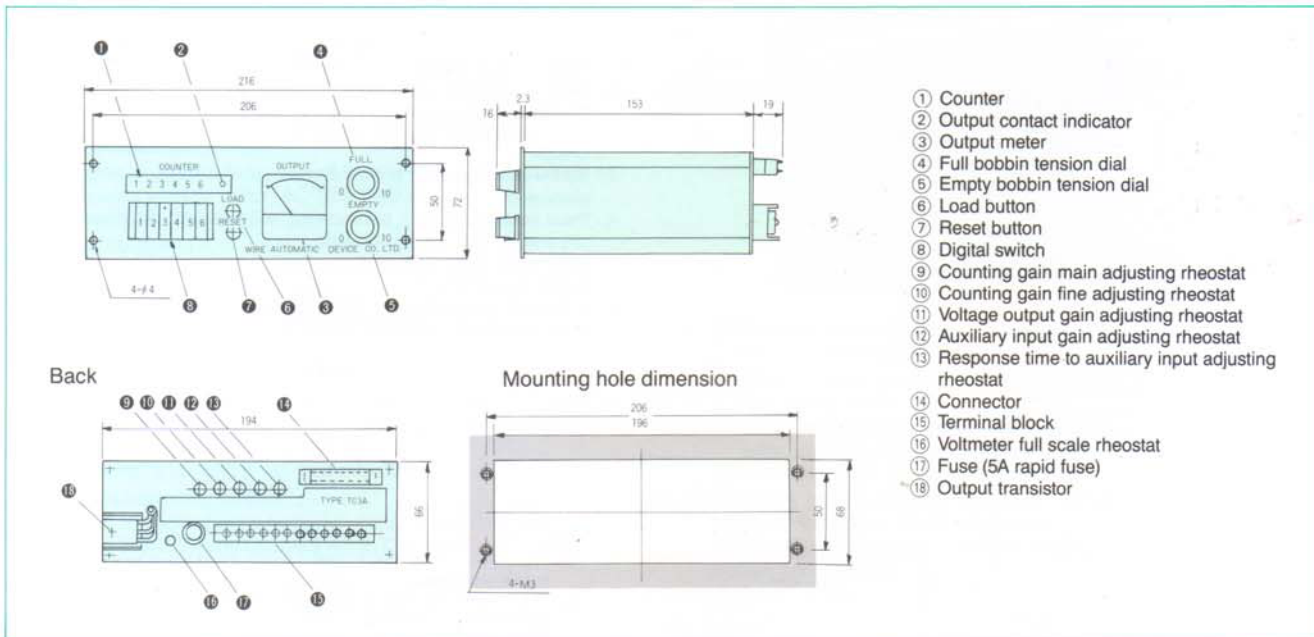

**Application**

The take up bobbin is driven by a motor via the powder clutch. The capstan draws the wire, which is coiled onto the take-up bobbin. The tension controller's empty bobbin and full bobbin tension dials are set, then push the reset button, and start the machine. The tension controller counts the length measuring pulse, that is generated from the proximity switch, and outputs the output voltage. This output voltage increases the converted torque of the powder clutch in proportion to the counting value. Therefore, the tension controller can keep the wire's tension constant from a coil empty to a coil full bobbin. In addition to the build-up tension control, the tension controller can automatically stop the machine when it reaches its preset length. With the use of optional units, the tension during accelerating and decelerating can also be easily controlled.

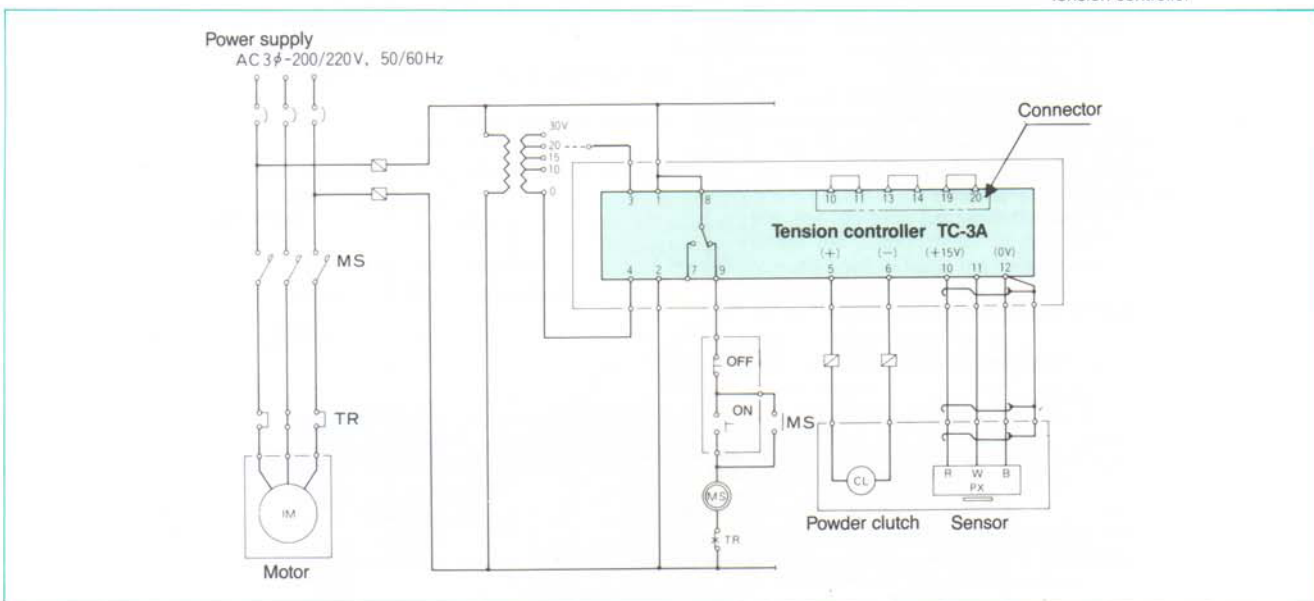
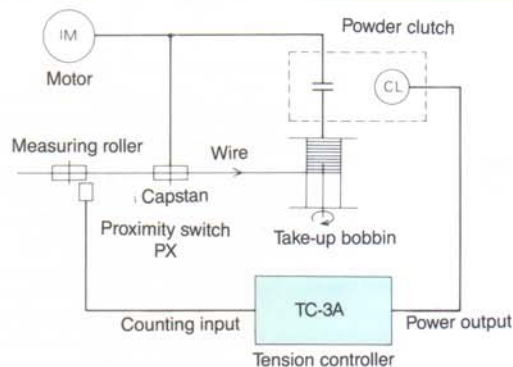

**WADECO CO.,LTD.**

HEAD OFFICE WADECO Bld., 1-12-9, Meishin-cho, Amagasaki-shi, Hyogo-ken 661-0021, Japan  
 TEL.+81-6-6482-3838 FAX.+81-6-6481-6321

TOKYO BRANCH 202 Shibuya-homes,2-1,Udagawa-cho,Shibuya-ku,Tokyo 150-0042,Japan  
 TEL.+81-3-3770-5519 FAX.+81-3-3770-5520

URL : <http://www.wadeco.co.jp>

This specification may be changed without notifying the buyer.