

Sentro 8 Sensorstation Eight-channel sensor monitoring station

Environments: Mining • Tunnelling

Applications: Underground storage areas • Underground transportation • Conveyor systems • Water utilities • Pump stations • Machine monitoring • Ventilation systems

Features

- Intelligent plug-in sensing modules are available for on-board gas detection (eModules) or remote sensor connections (rModules)
- Up to eight different gases, or a combination of eight remote sensors, can be monitored simultaneously without the need for complex system design
- All functions can be programmed externally using the heavy-duty waterproof keypad
- Programmable alarm setpoints can be user configured to activate the integral audio alarm and flashing visual warning
- Modbus data communications architecture allows up to 32 Sentro 8 Sensorstations on a single data cable to a central location reducing installation and cabling costs

Benefits

- Sentro 8 is convenient and compact, and has fewer failure risk points than traditional systems
- The backlit LCD screen provides clear information with direct on-screen instructions and diagnostic data
- Significant cost savings and safety improvements make a real impact on expenditure when applied across an entire industrial installation or throughout a global system structure
- System design is significantly reduced, with further economies in cabling, installation, commissioning, maintenance and downtime costs
- System installation, maintenance and servicing can be carried out without the need for specialist support
- Dual-wall housing gives maximum impact strength, and is protected against dust and moisture to IP65 and is EMC protected for use in arduous operating environments
- On a simple system, sensing module data logs are easily extracted for data analysis using an RS485 interface and PC application



Functional Overview

The Sentro eModule and rModule are at the heart of the Sentro 8. The Sentro eModule is an intelligent standardised gas sensing module that detects a range of toxic and flammable gases. Dynamic data is stored within the eModule, together with the condition of the gas sensing element and its service history.

You can easily service and calibrate the Sentro 8, or change to a different gas, by simply changing the eModule, even with the power still applied.

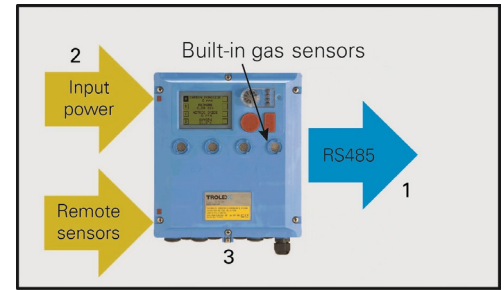

Hazardous area



eModule - fitted inside the Sentro 8

Technical Information

① Output:	RS485	
Electrical details:	General Purpose	Mining M1 (Exi)
② Supply voltage:	24 V dc/85 to 265 V ac	12 V dc
Supply current:	200 mA maximum loading including one pellistor eModule	
Output relays:	Four independent alarm relays each programmable to any alarm setpoint on any monitoring channel for preferred alarm priority grouping	
Relay contacts:	One changeover contact on each relay	
	2 Amps 230 V ac	Suitable for, and clearance compatible for, intrinsically safe circuits
Alarms:	Built-in visual alarms can be selected to operate at two adjustable set-points and high intensity audible sounder rated at 95 dB at 300 mm	
Operating temperature range:	-10 to +40 °C	
Humidity:	95%RH, non-condensing	
Storage temperature limits:	-20 to +60 °C	
③ Housing materials:	Reinforced polymer EMC protected and proof against surface electrostatic charge	
Protection classification:	Housing dust and waterproof to IP65 Gas port IP54	
Weight:	2.8 kg	
Mounting:	Two 6.5 mm diameter fixing holes (Unistrut 6946 compatible)	

Sentro Sensing Modules

A wide choice of interchangeable sensing modules is available, each with its own processor for intelligent data storage and signal conditioning circuits. They will detect most of the common toxic and flammable gases, or the same system architecture will measure any combination of remote sensors including flow, level, pressure, proximity, temperature, vibration and speed. Up to eight can be plugged into the Sentro 8 in any combination.

The modules are already calibrated so you can substitute them at any time with a replacement module in a matter of seconds. Each module contains its type identification and stores its full service history including gas identity, measuring range, data logging, predicted life span, calibration history, set points, failure modes and alarm setting. All the acquired data stays with the module throughout its functional life. On a simple system, sensor module data logs are easily extracted using an RS485 interface and PC application. Sensor module data logs can then be analysed for trends in gas concentrations, number of alarms, etc. On larger more complex systems sensor module data is automatically sent via the SCADA system.

There is no danger of inserting the wrong module. You can configure up to twenty insert codes and Sentro 8 automatically identifies the module that is inserted. Security coding is used to ensure that the same type of Sentro eModule is always used.

There are two basic module formats, the eModule and the rModule:



Sentro eModules are used for environmental gas concentration monitoring. Three types of eModules are available (detailed on page 4): electrochemical cells to detect toxic gases, catalytic combustion sensors to monitor flammable gases and infrared sensors to monitor Carbon Dioxide or Methane in the environment.

Sentro rModules are used for remote sensing devices such as flow sensors, vibration sensors and temperature sensors. The rModules are detailed on page 5.

Sentro eModules and rModules can be combined in almost any format and in any position. Sentro 8 will recognise the module when it is inserted and will quickly configure itself for immediate operation.

Note that eModules and rModules have separate order numbers and must be ordered as well as the required Sentro 8 model.

Sentro eModules

Electrochemical Cells for Toxic Gas Detection

Electromechanical cells monitor the concentration of toxic gases present in the environment. These cells combine good sensitivity at low gas concentration with high-range capability and excellent stability.



Carbon Monoxide (CO):	0 to 50 ppm*	TX6350.xx.250.50
	0 to 250 ppm*	TX6350.xx.250.250
	0 to 300 ppm*	TX6350.xx.250.300
	0 to 500 ppm*	TX6350.xx.250.500
	0 to 1000 ppm*	TX6350.xx.250.1000
Chlorine (CL₂):	0 to 10 ppm	TX6350.xx.255
Hydrogen (H₂):	0 to 1000 ppm	TX6350.xx.261
Hydrogen Sulphide (H₂S):	0 to 50 ppm*	TX6350.xx.251
Nitric Oxide (NO):	0 to 50 ppm*	TX6350.xx.259
Nitrogen Dioxide (NO₂):	0 to 10 ppm*	TX6350.xx.254.10
Nitrogen Dioxide (NO₂):	0 to 20 ppm*	TX6350.xx.254
Oxygen (O₂):	0 to 25% v/v	TX6350.xx.257
Sulphur Dioxide (SO₂):	0 to 20 ppm*	TX6350.xx.252

* selected eModules have STEL and TWA calculation capability

Poison-resistant Catalytic Sensor for Flammable Gas Detection

This sensor uses a poison-resistant catalytic combustion sensor to monitor flammable gases present in the atmosphere. The sensor responds to most flammable gases and vapours to varying degrees. It is normally calibrated to Methane in terms of % LEL or % volume, although calibration for other gases can be supplied (contact Trolex).

Methane (CH₄):	0 to 100% LEL	TX6350.xx.240
Methane (CH₄):	0 to 4% v/v	TX6350.xx.246
Methane (CH₄):	0 to 5% v/v	TX6350.01.244

Infrared Sensor for Carbon Dioxide / Methane Gas Detection

This infrared sensor monitors environmental concentrations of either Carbon Dioxide or Methane. It is highly specific to the selected gas and exhibits consistent sensing accuracy with superior long term stability, minimising calibration and maintenance.

Carbon Dioxide (CO₂):	0 to 2% v/v	TX6350.xx.253
Carbon Dioxide (CO₂):	0 to 5% v/v	TX6350.xx.278
Carbon Dioxide (CO₂):	0 to 100% v/v	TX6350.xx.279
Methane (CH₄):	0 to 100% LEL	TX6350.xx.245
Methane (CH₄):	0 to 5% v/v	TX6350.xx.243
Methane (CH₄):	0 to 100% v/v	TX6350.xx.242

Remember to order the eModule you require when you order the Sentro 8. Replace xx with 01 for Group 1 eModules and with 03 for General Purpose eModules.

For details of the full range of gas sensors contact the Trolex Sales Team: sales@trolex.com

Sentro rModules

Any remotely connected auxiliary sensors can be connected into the Sentro 8, in any combination, as part of an integrated monitoring system. The Sentro rModule also provides power to drive the remote sensor.

Remotely Connected Sensors

The list below details the remotely connected sensors that can be connected to different rModules:



0.4 to 2.0V:	Voltage input signals, analogue sensor input, 2 and 3-wire connections.	TX9160.xx.303
4 to 20 mA:	Industrial standard analogue sensor input, 2 and 3-wire connections.	TX9160.xx.301
On/Off:	NAMUR proximity switch with line fault monitoring. Examples include conventional contacts, pressure switches, limit switches, etc.	TX9160.xx.501
On/Off & Diode:	On/Off switch inputs with diode line protection.	TX9160.xx.502
PT100:	Standard PT100 temperature monitoring input with line compensation.	TX9160.xx.306

Remember to order the rModule you require when you order the Sentro 8. Replace xx with 01 for Group 1 rModules and with 03 for General Purpose rModules.

Individual Configuration(s) for any Monitoring Application

Environmental Monitoring System

A Sentro 8 Sensorstation configured for environmental monitoring, fitted with four Sentro eModules for:

- Oxygen
- Methane
- Carbon Monoxide
- Hydrogen Sulphide

Four additional Sentro rModules for remote mounted sensors to provide safety condition monitoring:

- Air flow sensor
- Pressure sensor
- Vibration sensor
- Temperature sensor



Environmental and Safety Monitoring System

A Sentro 8 Sensorstation with eight Sentro rModules for remote mounted sensors on a machine condition monitoring system:

- 2 x air flow sensors
- 2 x pressure sensors
- 2 x vibration sensors
- 2 x temperature sensors



Condition Monitoring System

A Sentro 8 Sensorstation with one Sentro eModule for single gas sensing.

Six Sentro rModules for remote mounted sensors on a ventilation fan:

- 2 x air flow sensors
- 2 x vibration sensors
- Pressure sensor
- Temperature sensor



Dimensions

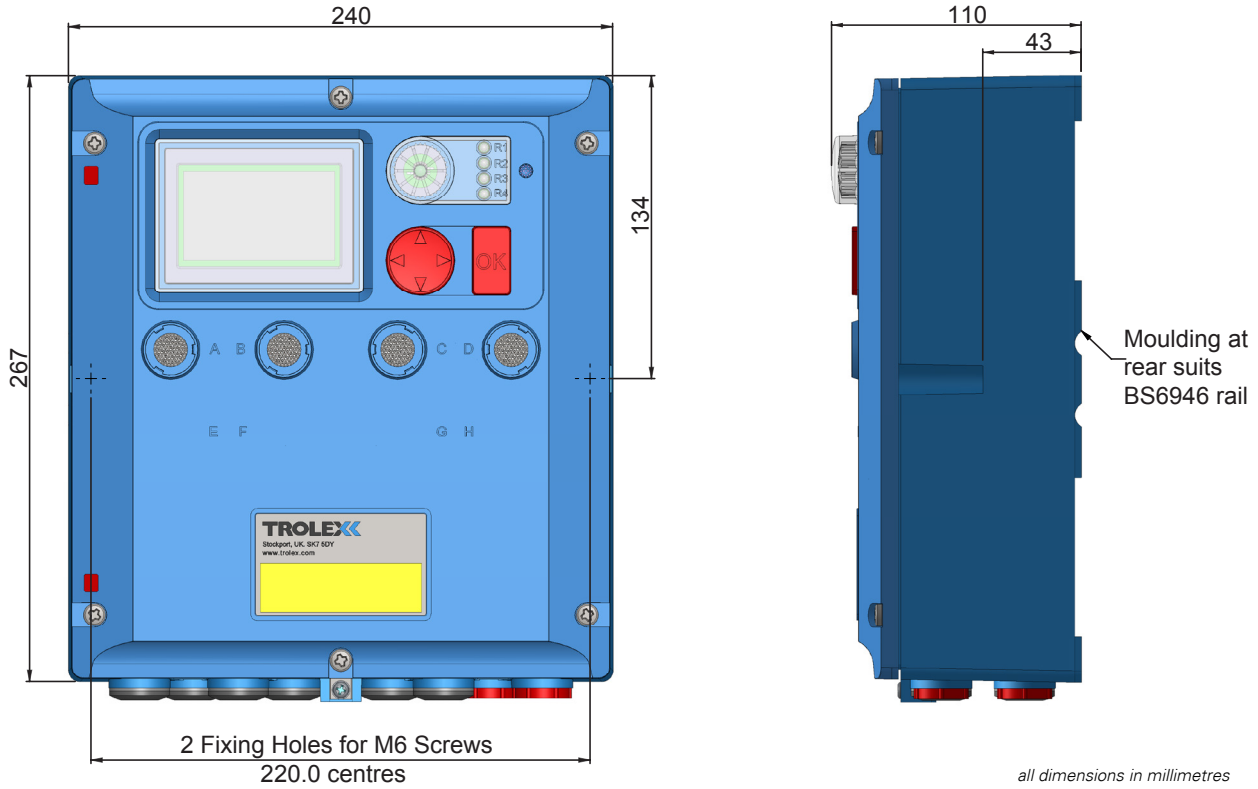

Connections

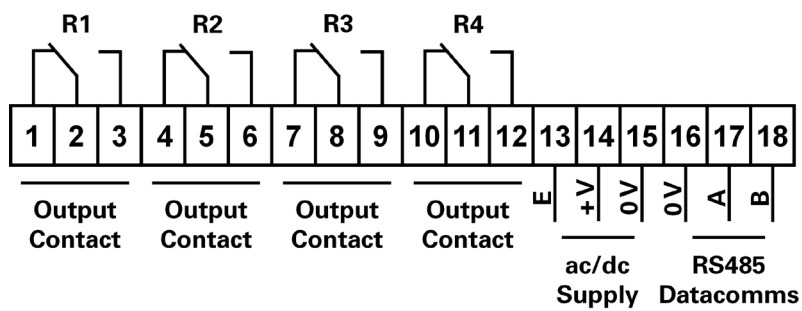

Order Reference

TX9165.01	Sentro 8 Sensorstation - Group 1 - 12 V dc
TX9165.03.102	Sentro 8 Sensorstation - General Purpose - 24 V dc
TX9165.03.114	Sentro 8 Sensorstation - General Purpose - 85 to 265 V ac (universal)
P9000.223.01	Battery Back-up Unit
P9000.223.02	Battery Back-up Unit with RS485 Repeater
P9000.223.03	Battery Back-up Unit with Ethernet Converter



Remember to order the required eModules or rModules order reference (see pages 4 & 5).

Please contact the Trolex Sales Team for further information and advice:

+44 (0)161 483 1435
sales@trolex.com

Certifications



Europe:
Certified intrinsically safe for use in underground mines:
TX9165.01.i Sentro 8 Sensorstation (Group 1)
Ex Certificate Number: SIRA 09ATEX2285X

I M1 Ex ia I Ma



ATEX directive 94/9/EC
EMC directive 2004/108/EC



International (IECEx):
TX9165.01.i Sentro 8 Sensorstation (Group 1)
Ex Certificate number: IECEx SIR 09.0120X

Ex ia I Ma



Russia (Customs Union):
Ex Certificate number: RU C-GB.ГБ05.B.00616

PO Ex ia I Ma X



South Africa (MASC):
Ex Certificate number: MASC M/11-420

Ex ia I Ma

Copyright and Trademarks

© 2015 Trolex® Limited.

Trolex is a registered trademark of Trolex Limited. The use of all trademarks in this document is acknowledged.

Document history:	Issue 03	2 December 2014	Third publication of this document
	Issue 04	8 June 2015	Fourth publication of this document

Trolex Limited

Newby Road, Hazel Grove, Stockport, Cheshire SK7 5DY, United Kingdom
+44 (0)161 483 1435 sales@trolex.com www.trolex.com

