

UPT-6010 [®]

Operating instructions



The UPT-6010 temperature controller is a key component in an ULTRA-PULSE system, because it is responsible for all heat management functions, i.e. controlling the temperature of the heating element.

Important features

- Microprocessor technology
- Complete control via PROFINET interface ("Conformance Class B", IO / RT acc. to IEC 61784-2) (2 x RJ-45)
- Automatic zero calibration (AUTOCAL)
- Automatic configuration of the secondary voltage and current ranges (AUTORANGE)
- Automatic frequency adjustment
- Large current and voltage range
- Booster connection as standard
- 0...10VDC analog output for ACTUAL temperature
- Alarm function with error diagnosis
- Heatsaling element alloy and temperature range selectable
- Cooling system monitored

Contents

1	Safety and warning notes	3	8	Startup and operation	17
1.1	Use	3	8.1	View of the controller	17
1.2	Heating element	3	8.2	Controller configuration	17
1.3	Impulse transformer	3	8.3	Heating element	19
1.4	Current transformer PEX-W2/-W3	3	8.4	Startup procedure	20
1.5	Line filter	3	9	Controller functions	22
1.6	Standards / CE marking	4	9.1	LEDs and controls	22
1.7	Warranty provisions	4	9.2	PROFINET communication	24
2	Application	4	9.3	Device master file (GSDML)	24
3	System description	5	9.4	Communication protocol	25
3.1	Temperature controller	5	9.5	Input data	25
3.2	Current transformer	6	9.6	Output data	27
3.3	Booster	6	9.7	Parameter data	29
4	Accessories and modifications	6	9.8	Undervoltage detection	33
4.1	Accessories	6	9.9	Temperature indication (actual value output)	33
4.2	Modifications (MODs)	7	9.10	Booster connection	34
5	Technical data	8	9.11	Diagnostic interface / visualization software	34
6	Dimensions	10	9.12	Total cycle counter	35
7	Installation	11	9.13	Operating hours counter	35
7.1	Installation steps	11	9.14	Data memory for error messages and AUTOCAL	35
7.2	Installation steps	11	9.15	Integrated clock (date and time)	35
7.3	Installation procedure	11	9.16	System monitoring / alarm output	36
7.4	Power supply	13	9.17	Error messages	37
7.5	Line filter	14	9.18	Fault areas and causes	40
7.6	Current transformer PEX-W3	14	10	Factory settings	42
7.7	Wiring diagram (standard)	15	11	Maintenance	42
7.8	Wiring diagram with booster connection	16	12	How to order	43
			13	Index	44

1 Safety and warning notes

This CIRUS temperature controller is manufactured according to DIN EN 61010-1. In the course of its manufacture it passed through quality assurance, whereby it was subjected to extensive inspections and tests.

It left the factory in perfect condition.

The recommendations and warning notes contained in these operating instructions must be complied with, in order to guarantee safe operation.

The device can be operated within the limits indicated in the "Technical Data" without impairing its operational safety. Installation and maintenance may only be performed by technically trained, skilled persons who are familiar with the associated risks and warranty provisions.

1.1 Use

CIRUS temperature controllers may only be used for heating and temperature control of heatsealing elements which are expressly suitable for them, and providing the regulations, notes and warnings contained in these instructions are complied with.

 **In case of non-compliance or use contrary to the intended purpose, there is a risk that safety will be impaired or that the heatsealing element, electrical wiring, transformer etc. will overheat. Ensuring such compliance is the personal responsibility of the user.**

1.2 Heating element

The temperature coefficient of a CIRUS temperature controller is specially adapted to CIRUS heating elements.

 **The controller is not allowed to be operated with any other heatsealing bands because they could be overheated and damaged beyond repair.**

1.3 Impulse transformer

A suitable impulse transformer is necessary to ensure that the control loop functions perfectly. This

transformer must be designed according to VDE 0570/ EN 61558 (isolating transformer with reinforced insulation) and have a one section bobbin. When the impulse transformer is installed, suitable shock protection must be provided in accordance with the national installation regulations for electrical equipment. In addition, water, cleaning solutions and conductive fluids must be prevented from seeping into the transformer.

 **Incorrect installation of the impulse transformer impairs electrical safety.**

1.4 Current transformer PEX-W2/W3

The current transformer supplied with the CIRUS temperature controller is an integral part of the control system.

 **Only the original ROPEX PEX-W2 or PEX-W3 current transformer may be used. Other transformers may cause the equipment to malfunction.**

The current transformer may only be operated if it is connected to the CIRUS temperature controller correctly (see section 9, "Startup and operation"). The relevant safety instructions contained in section 8.3, "Power supply", must be obeyed. External monitoring modules can be used in order to additionally increase operating safety. They are not included in the scope of supply of the standard control system and are described in a separate document.

1.5 Line filter

The use of an original ROPEX line filter is mandatory in order to comply with the standards and provisions mentioned in section 8.3 "Standards / CE marking" on page 1. This device must be installed and connected according to the instructions contained in section 8.3, "Power supply" as well as the separate documentation enclosed with the line filter.

1.6 Standards / CE marking

The controller described here complies with the following standards, provisions and directives:

DIN EN 61010-1:2001 (2006/95/EG)	Safety requirements for electrical equipment for measurement, control and laboratory use (low-voltage directive): pollution degree 2, protection class II, measurement category I (for U_R and I_R terminals)
DIN EN 60204-1 (2006/42/EG)	Electrical equipment of machines (machinery directive)
EN 55011:1998 + A1:1999 + A2:2002 EN 61000-3-2:2006-04 EN 61000-3-3:1995-01 + A1:2001 + A2:2005-11 (2004/108/EG)	EMC genery emissions: Group 1, Class A
EN 61000-6-2:2005 (2004/108/EG)	EMC generic immunity: Class A (ESDs, RF radiation, bursts, surges) <u>Exception:</u> Line voltage interruption acc. EN 61000-4-11 is not fulfilled (This leads to a designated error message of the controller)

Compliance with these standards and provisions is only guaranteed if original accessories and/or peripheral components approved by ROPEX are used. If not, then the equipment is operated on the user's own responsibility.

2 Application

This CIRUS temperatue controller is an integral part of the "series 6000". Its sole purpose is to control the temperature of CIRUS/UPT heating elements, wich are used mainly for Impulse-heatsealing PP and RE films.

The CE marking on the controller confirms that the device itself complies with the above-mentioned standards.

It does not imply, however, that the overall system also fulfils these standards.

It is the responsibility of the machine manufacturer and of the user to verify the completely installed, wired and operationally ready system in the machine with regard to its conformity with the safety provisions and the EMC directive (see also section 8.3, "Power supply"). If peripheral components (e.g. the transformer or the line filter) from other manufacturers are used, no functional guarantee can be provided by ROPEX.

1.7 Warranty provisions

The statutory provisions for warranties apply for a period of 12 months following the delivery date.

All devices are tested and calibrated in the factory. Devices that have been damaged due to faulty connections, dropping, electrical overloading, natural wear, incorrect or negligent handling, chemical influences or mechanical overloading as well as devices that have been modified, relabeled or otherwise altered by the customer, for example in an attempt to repair them or install additional components, are excluded from the warranty.

Warranty claims must be examined in the factory and approved by ROPEX.

The most important applications are packaging machines, pouch-making machines, splicers, machines for making pharmaceutical and medical products etc.

3 System description

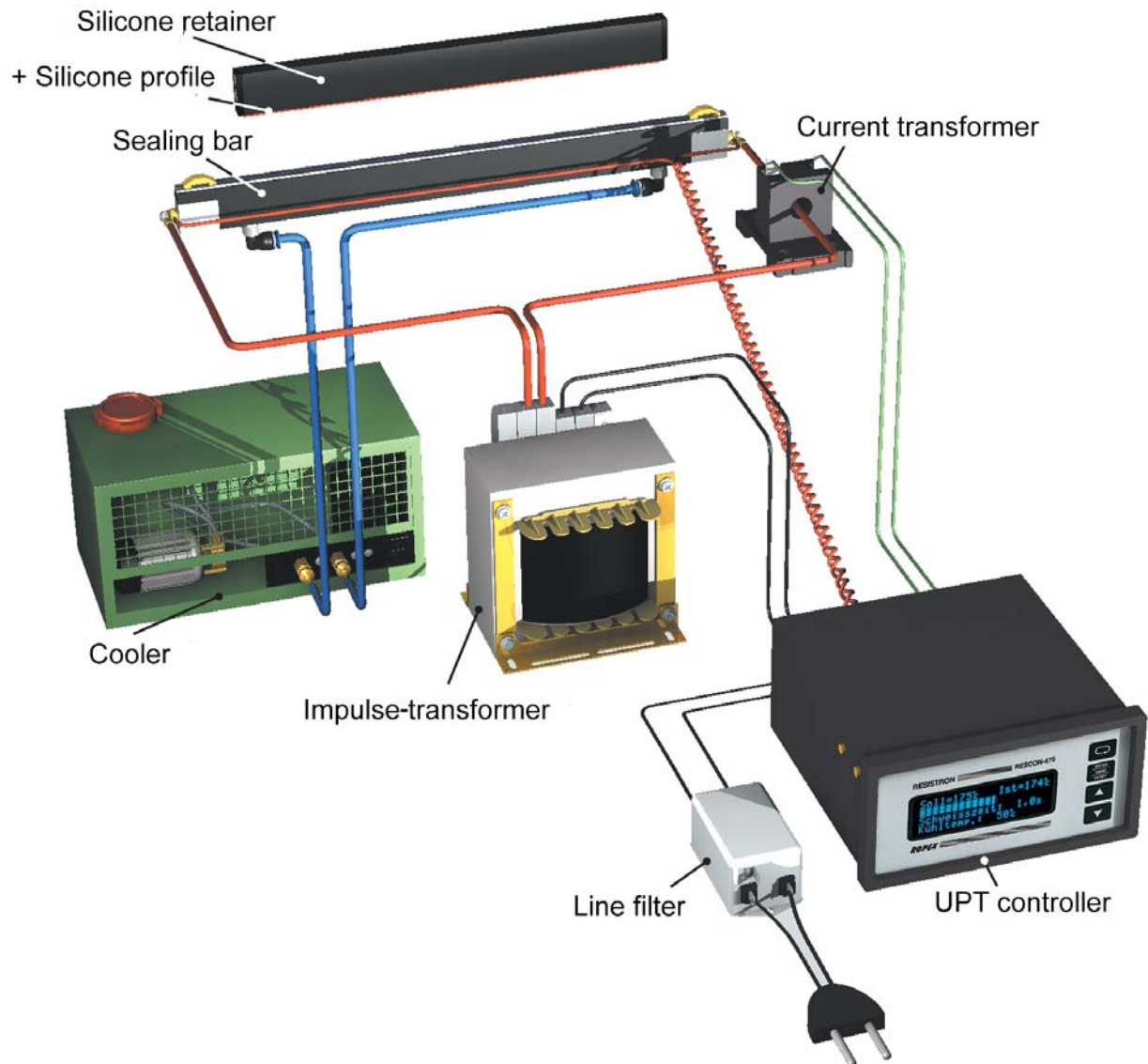

The basic design of the overall system is shown in the diagram above.

CIRUS heating elements, and in particular UPT heating elements, are high-performance systems which operate efficiently and reliably providing all the components in the control loop are optimally tuned to one another – and to the task at hand. Exact compliance with the installation and wiring instructions is essential. The system has been evolved and optimized by ROPEX GmbH in an intensive development process. Users who follow our technical recommendations will profit from the unique functionality of this technology, which reduces the customer's effort for installation, commissioning and maintenance to a minimum.

3.1 Temperature controller

The controller calculates the resistance of the heating element by measuring the current and voltage at a high sampling rate (= line frequency), compares it with the set point and – if the difference is not 0 – adjusts the heating current with the help of a phase angle-controlled transformer so that set = actual.

The fact that purely electrical variables are measured in quick succession and the small mass of the heating

layer of the UPT heating element together result in a highly dynamic, thermo-electrical control loop.

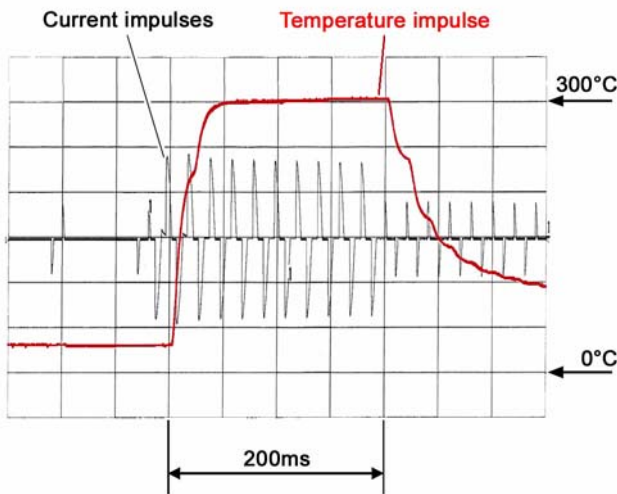

Thanks to its microprocessor based technology, the controller features an optimized control algorithm as well as numerous functions tailored to the various tasks, such as "AUTOCAL", ALARM with fault diagnosis etc. These are described in detail below.

The CIRUS temperature controller UPT-6010 is equipped with two PROFINET interfaces. These interfaces can be used to control all the controller functions and interrogate controller information.

The ACTUAL temperature of the heating element is supplied to the PROFINET interface and to an analog 0 to 10V DC output. The real heating element tempera-

ture can thus be displayed on an external temperature meter (e.g. ATR-x).

The UPT-6010 features an integrated fault diagnosis function, which tests both the external system (heating element, wiring etc.) and the internal electronics and outputs a selective error message in case of a fault.

To increase operational safety and interference immunity, all PROFINET signals are electrically isolated from the controller and the heating circuit.

The compact design of the CIRUS temperature controller UPT-6010 and the plug-in connections make this controller easy to install.

3.2 Current transformer

The PEX-W2 or PEX-W3 current transformer supplied with the CIRUS UPT-6010 controller is an integral part of the control system. Only this original ROPEX current transformer is allowed to be used.

Never attempt to operate the current transformer with open connections!

3.3 Booster

If the maximum load exceeds the rated current of the controller (☞ section 5 "Technical data" on page 8), an external switching amplifier (booster) must be used (☞ section 4.1 "Accessories" on page 6).

The other system components – UPT sealing bars, transformers, filter, cooler etc. – are described in separate brochures.

4 Accessories and modifications

A wide range of compatible accessories and peripheral devices are available for the CIRUS temperature controller UPT-6010. They allow it to be optimally adapted to your specific heatsealing application and to your plant's design and operating philosophy.

4.1 Accessories

The products described below are only a few of the wide range of accessories available for CIRUS temperature controllers (☞ "Accessories" leaflet).



Analog temperature meter ATR-x

For front panel mounting or mounting on a top hat rail (DIN TS35 rail).

Analog indication of the ACTUAL temperature of the heating element in °C. The meter damping of the unit is optimized for the abrupt temperature changes that occur in impulse mode.

	<p>Digital temperature meter DTR-x For front panel mounting or mounting on a top hat rail (DIN TS35 rail). Digital indication of the ACTUAL temperature of the heating element in °C, with HOLD function.</p>
	<p>Line filter LF-xx480 Essential in order to ensure CE conformity. Optimized for the CIRUS temperature controller.</p>
	<p>Impulse transformer ITR-x Designed according to VDE 0570/EN 61558 with a one section bobbin. Optimized for impulse operation with CIRUS temperature controllers. Specified according to the heatsealing application (↪ ROPEX Application Report).</p>
	<p>Communication interface CI-USB-1 Interface for connecting a RESISTRON temperature controller with diagnostic interface (DIAG) to the PC (USB port). Associated PC visualization software for displaying setting and configuration data, and for recording SET and ACTUAL temperatures in real time.</p>
	<p>Booster B-xxx400 External switching amplifier, necessary for high primary currents (continuous current > 5A, pulsed current > 25A).</p>
	<p>Monitoring current transformer For detecting frame short-circuits on the heating element. Used as an alternative to the standard PEX-W2/-W3 current transformer.</p>
	<p>Measurement cable UML-1 twisted measurement cable for the U_R-voltage measurement. Trailing cable, halogene und silicone free.</p>

4.2 Modifications (MODs)

Owing to its universal design, the CIRUS temperature controller UPT-6010 is suitable for a very wide range of heatsealing applications. One modification (MOD) is available for the CIRUS temperature controller UPT-6010 for implementing special applications.

MOD 01

Amplifier for low secondary voltages ($U_R = 0.25...16VAC$). This modification is necessary, for example, for very short or low-resistance heating elements.

5 Technical data

Type of construction	Housing for installation in the electrical cabinet Snaps onto a standard top hat rail (DIN TS35 rail, 35mm) acc. to DIN EN 50022 Dimensions: 90 x 75mm; height: 135mm (incl. terminals)
Line voltage	400VAC version: 380VAC -15%...415VAC +10% (equivalent to 323...456VAC) Depending on the version selected (↪ section 12 "How to order" on page 43)
Power supply system	Balanced TN or TT system, max. 415VAC Installation category III  Operation in a potential-free system (e.g. an IT system) is only permitted after consultation with ROPEX.
Line frequency	47...63 Hz, automatic adjustment to frequencies in this range
24VDC supply voltage Terminals 19+20	24VDC, I _{max} = 200mA Tolerance: ±10%
Measuring range	Secondary voltage U _R : 0.4...120VAC Secondary current I _R : 30...500A (with PEX-W2/-W3 current transformer) ↪ ROPEX Application report
PROFINET interface	"Conformance Class B", IO / RT acc. to IEC 61784-2 2 Ethernet switch ports RJ45 Wiring: IEC61784-5-3 Baud rate: 100MHz Data transport layer: Ethernet II, IEEE 802.3 Topology discovery: LLDP, SNMP V1, MIB2, physical device Addressing: DCP or selectable with rotary coding switch FSU (Fast Startup) support: Yes, but startup time approx. 1.5s.
Heatsealing element type and temperature range	The temperature range and temperature coefficient settings can also be specified by means of the ROPEX visualization software (↪ section 9.11 "Diagnostic interface / visualization software" on page 34) in addition to the rotary coding switch or the PROFINET interface (see below): Temperature range: 200°C, 300°C, 400°C, or 500°C Temperature coefficient: 400...4000ppm/K (variable setting range) Two different ranges can be set with the rotary coding switch or via the PROFINET interface: Temperature coefficient 1700ppm/K, 0...300°C (CIRUS) Temperature coefficient 1700ppm/K, 0...500°C (CIRUS)
Analog output (actual value) Terminals 17+18	0...10VDC, I _{max} = 5mA Equivalent to 0...300°C or 0...500°C Accuracy: ±1% plus 50mV
Fault relay Terminals 12, 13, 14	U _{max} = 30V (DC/AC), I _{max} = 0.2A, changeover contact, potential-free

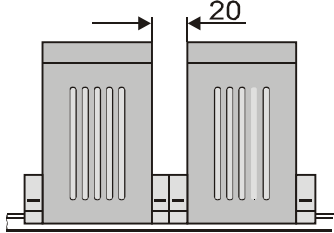
Current consumption (primary current of impulse transformer)	$I_{max} = 5A$ (duty cycle = 100%) $I_{max} = 25A$ (duty cycle = 20%)
Power dissipation	Max. 20W
Ambient temperature	+5...+45°C
Degree of protection	IP20
Installation	<p>A minimum safety clearance of 20mm all round (e.g. from other devices and wiring) must be allowed when installing the controller.</p> <p>The moving clip required for fastening must be facing down for mounting on a horizontal top hat rail.</p> <p>End holders to mechanically fix the controller must be fitted at both ends for mounting on a vertical top hat rail.</p> 
Weight	Approx. 0.5kg (incl. connector plug-in parts)
Housing material	Plastic, polycarbonate, UL-94-V0
Connecting cables Type / cross-sections	<p>Rigid or flexible; 0.2...2.5mm² (AWG 24...12) Plug-in connectors</p> <p>Screw terminals: Clamping torque: 0.5...0.6Nm (Screw driver size: SZS 0.6x3.5mm)</p> <p>⚠ If ferrules are used, they must be crimped in accordance with DIN 46228 and IEC / EN 60947-1. This is essential for proper electrical contact in the terminals.</p>

6 Dimensions

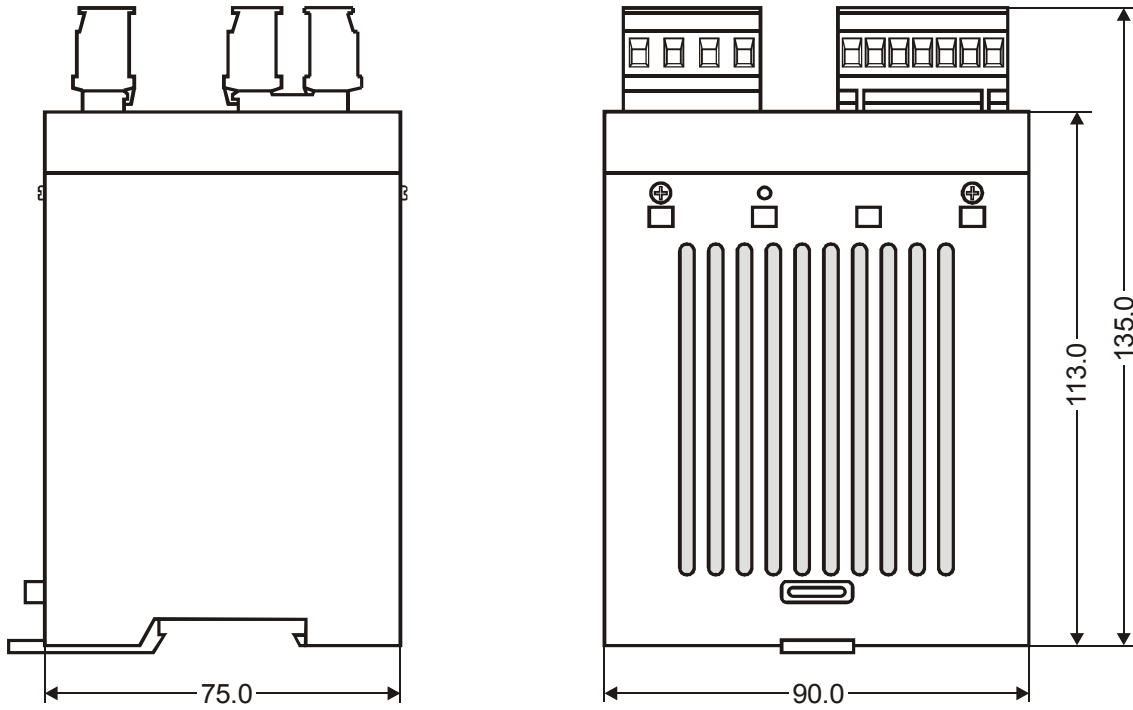

7 Installation

↳ See also section 1 "Safety and warning notes" on page 3.

⚠ Installation and startup may only be performed by technically trained, skilled persons who are familiar with the associated risks and warranty provisions.

7.1 Installation steps

1. Please refer to the safety and warning notes (↳ section 1 "Safety and warning notes" on page 3).
2. The information provided in the customized ROPEX Application Report, which is prepared by ROPEX specifically for each application, should be heeded at all times.
3. All electrical components, such as the controller, the impulse transformer and the line filter, should be installed as close as possible to the UPT sealing bar(s) in order to avoid long wires.
4. Connect the voltage measurement cable U_R directly to the UPT sealing bar and lay it twisted to the controller (UML-1 voltage measurement cable ↳ section 4 "Accessories and modifications" on page 6).
5. Ensure an adequate cable cross-section for the primary and secondary circuits (↳ Application Report).
6. Use only ROPEX impulse transformers or transformers approved by ROPEX. Please note the power, the duty cycle and the primary and secondary voltages (↳ Application Report).

7.2 Installation steps

1. Please refer to the safety and warning notes (↳ section 1 "Safety and warning notes" on page 3).
2. The information provided in the customized ROPEX Application Report, which is prepared by ROPEX specifically for each application, should be heeded at all times.
3. All electrical components, such as the controller, the impulse transformer and the line filter, should be installed as close as possible to the UPT sealing bar(s) in order to avoid long wires.
4. Connect the voltage measurement cable U_R directly to the UPT sealing bar and lay it twisted to the controller (UML-1 voltage measurement cable

↳ section 4 "Accessories and modifications" on page 6).

5. Ensure an adequate cable cross-section for the primary and secondary circuits (↳ Application Report).
6. Use only ROPEX impulse transformers or transformers approved by ROPEX. Please note the power, the duty cycle and the primary and secondary voltages (↳ Application Report).

7.3 Installation procedure

Proceed as follows to install the CIRUS temperature controller UPT-6010:

1. Switch off the line voltage and verify that the circuit is de-energized.
2. The supply voltage specified on the nameplate of the CIRUS temperature controller must be identical to the line voltage that is present in the plant or machine. The line frequency is automatically detected by the CIRUS temperature controller in the range from 47Hz...63Hz.
3. Install the CIRUS temperature controller in the electrical cabinet on a standard top hat rail (DIN TS35 rail, according to DIN EN 50022). If several controllers are installed on one top hat rail, the minimum clearance specified in section 5 "Technical data" on page 8 must be allowed between them.
4. Wire the system in accordance with the instructions in section 7.4 "Power supply" on page 13, section 7.7 "Wiring diagram (standard)" on page 15 and the ROPEX Application Report. The information provided in section 7.4 "Power supply" on page 13 must also be heeded additionally.

An overcurrent protective device (e.g. a fuse) with a maximum rating of 10A must be fitted when the controller is installed provided this is adequate for the heatsealing application. If not, two separate overcurrent protective devices should be provided, one for the controller and one for the application (↳ ROPEX Application report).

The minimum possible specification for this device must be entered in the ROPEX Application Report based on the calculated currents. If a larger overcurrent protective device is fitted, you must match the current carrying capacity of the other components accordingly (e.g. cables, impulse transformer etc.).

5. Connect the CIRUS temperature controller to the

PROFINET-Controller using a cable according to.

6. Make sure that the wiring conforms to the relevant national and international installation regulations.



Check the tightness of all the system connections, including the terminals for the impulse transformer windings.

7.4 Power supply

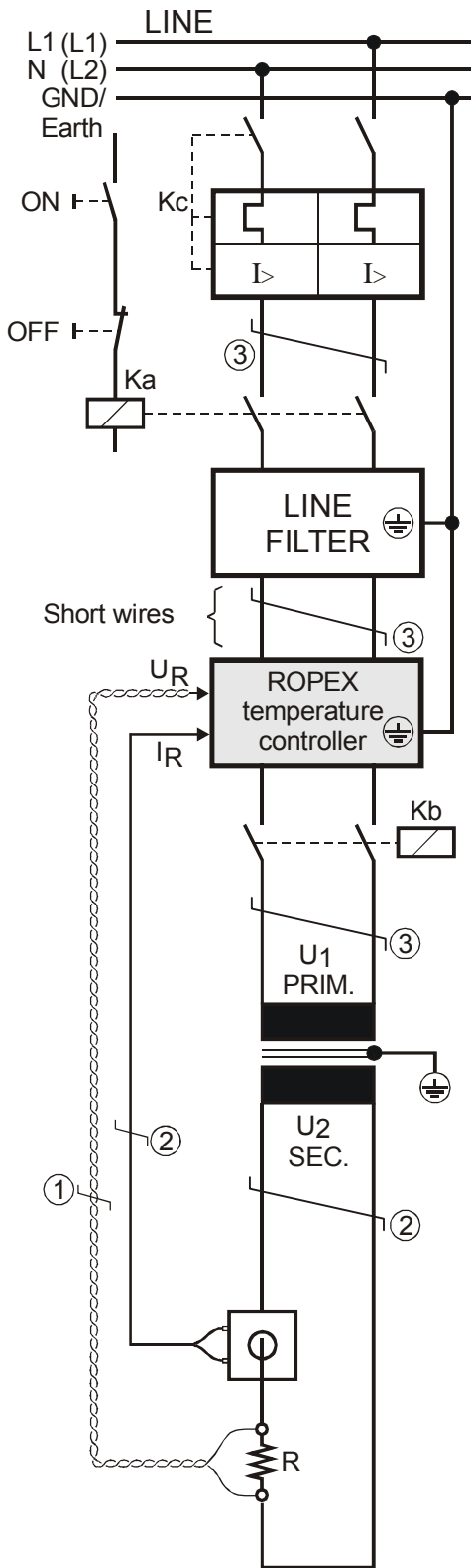

Line

400VAC
50/60Hz

Over-current protection

Double-pole circuit-breaker or fuses,
(☞ ROPEX Application Report)

- ⚠ Short-circuit protection only.
- ⚠ CIRUS temperatue controller not protected.

Relay Ka

For "HEAT ON - OFF" function (all-pole) or "EMERGENCY STOP".

Line filter

The filter type and size must be determined according to the load, the transformer and the machine wiring (☞ ROPEX Application Report).

- ⚠ Do not run the filter supply wires (line side) parallel to the filter output wires (load side).

CIRUS temperatue controller belonging to the 6xx Series.

Relay Kb

Load break (all-pole), e.g. in combination with the alarm output of the temp. controller (ROPEX recommendation).

- ⚠ When using a series resistor RV-....-1 the relay Kb shall be installed.

Impulse Transformer

Designed according to VDE 0570/EN 61558 (isolating transformer with reinforced insulation). Connect core to ground.

- ⚠ Use transformers with a one section bobbin. The power, duty cycle and voltage values must be determined individually according to the application (☞ ROPEX Application Report and "Accessories" leaflet for impulse transformers).

Wiring

The wire cross-sections depend on the application (☞ ROPEX Application Report).

Guide values:

Primary circuit: min. 1.5mm², max. 2.5mm²
Secondary circuit: min. 4.0mm², max. 25mm²

- ① These wires must always be twisted (>20turns/meter).
- ② These wires must be twisted (>20turns/meter) if several control loops are laid together ("crosstalk").
- ③ Twisting (>20turns/meter) is recommended to improve EMC.

7.5 Line filter

To comply with EMC directives – corresponding to EN 50081-1 and EN 50082-2 – RESISTRON control loops must be operated with line filters.

These filters damp the reaction of the phase-angle control on the line and protect the controller against line disturbances.

⚠ The use of a suitable line filter is part of the standards conformity and a prerequisite of the CE mark.

installed and wired correctly, they guarantee compliance with the EMC limit values.

You can find the exact specification of the line filter in the ROPEX Application Report calculated for your particular heatsealing application.

For more technical information: ↪ "Line filter" documentation.

⚠ It is permissible to supply several CIRUS control loops with a single line filter, providing the total current does not exceed the maximum current of the filter.

ROPEX line filters are specially optimized for use in RESISTRON control loops. Providing that they are

The wiring instructions contained in section 7.4 "Power supply" on page 13 must be observed.

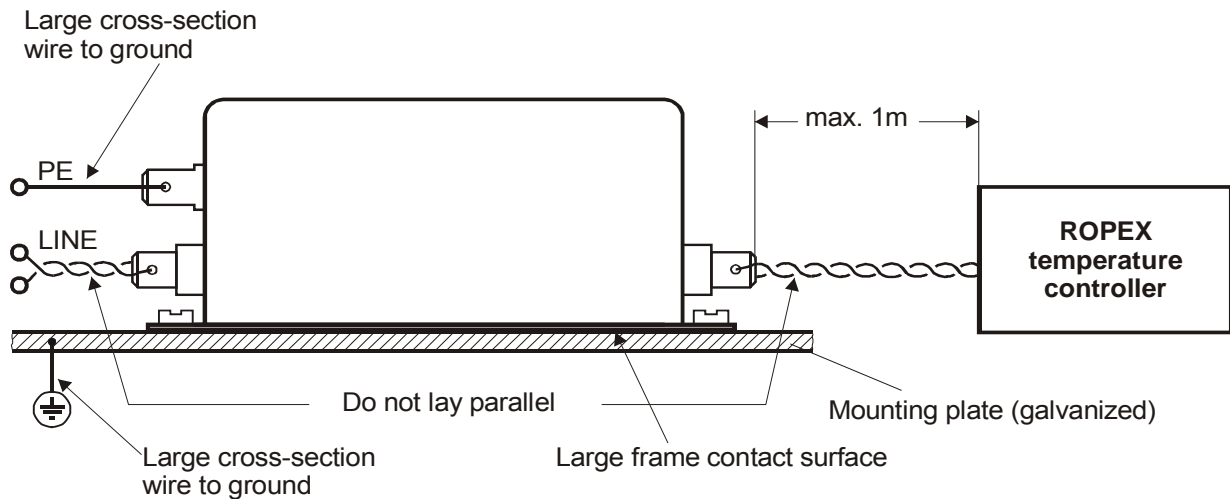

7.6 Current transformer PEX-W3

The PEX-W3 current transformer supplied with the RESISTRON temperature controller is an integral part

of the control system. The current transformer may only be operated if it is connected to the temperature controller correctly (↪ section 7.4 "Power supply" on page 13).

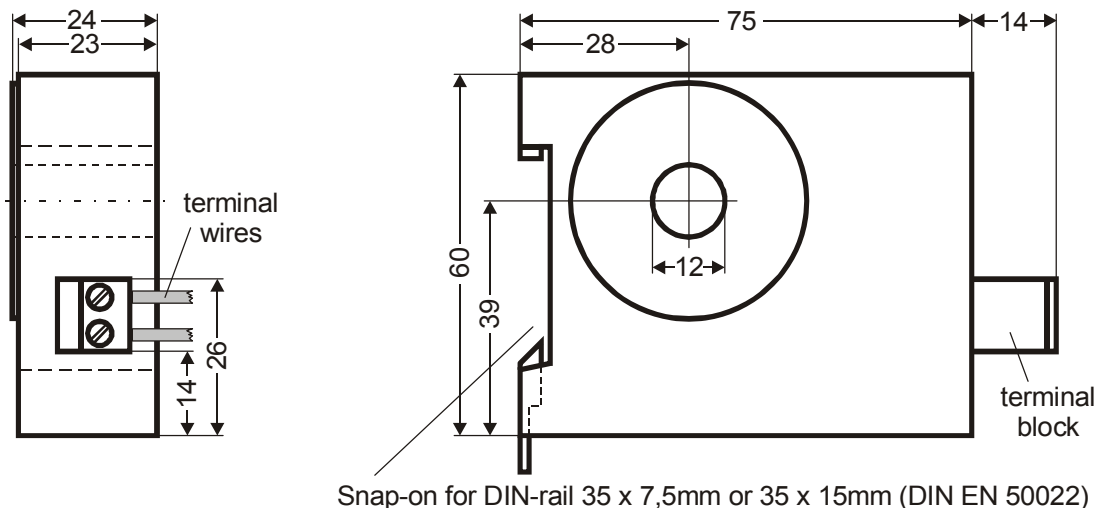

7.7 Wiring diagram (standard)

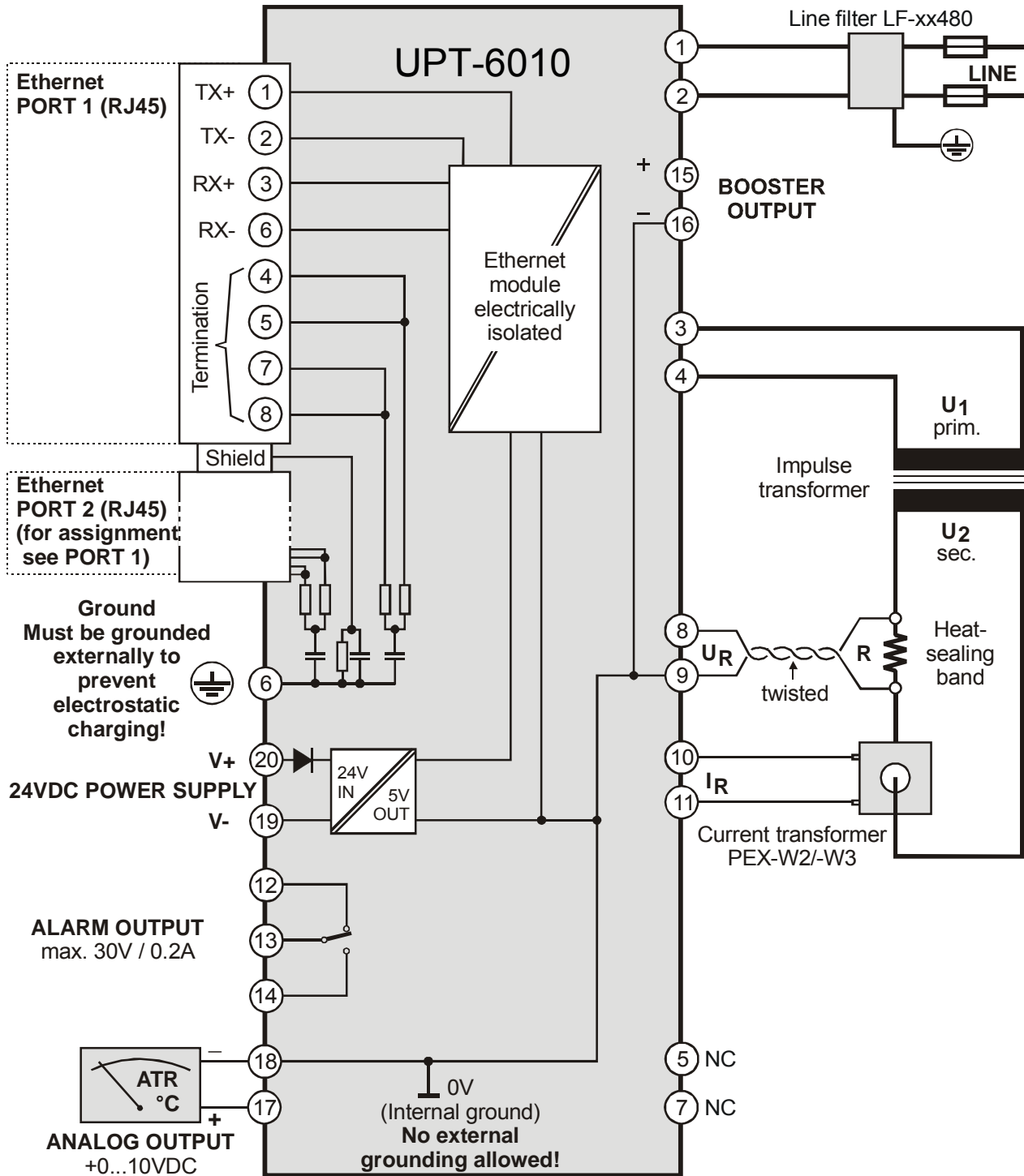

7.8 Wiring diagram with booster connection

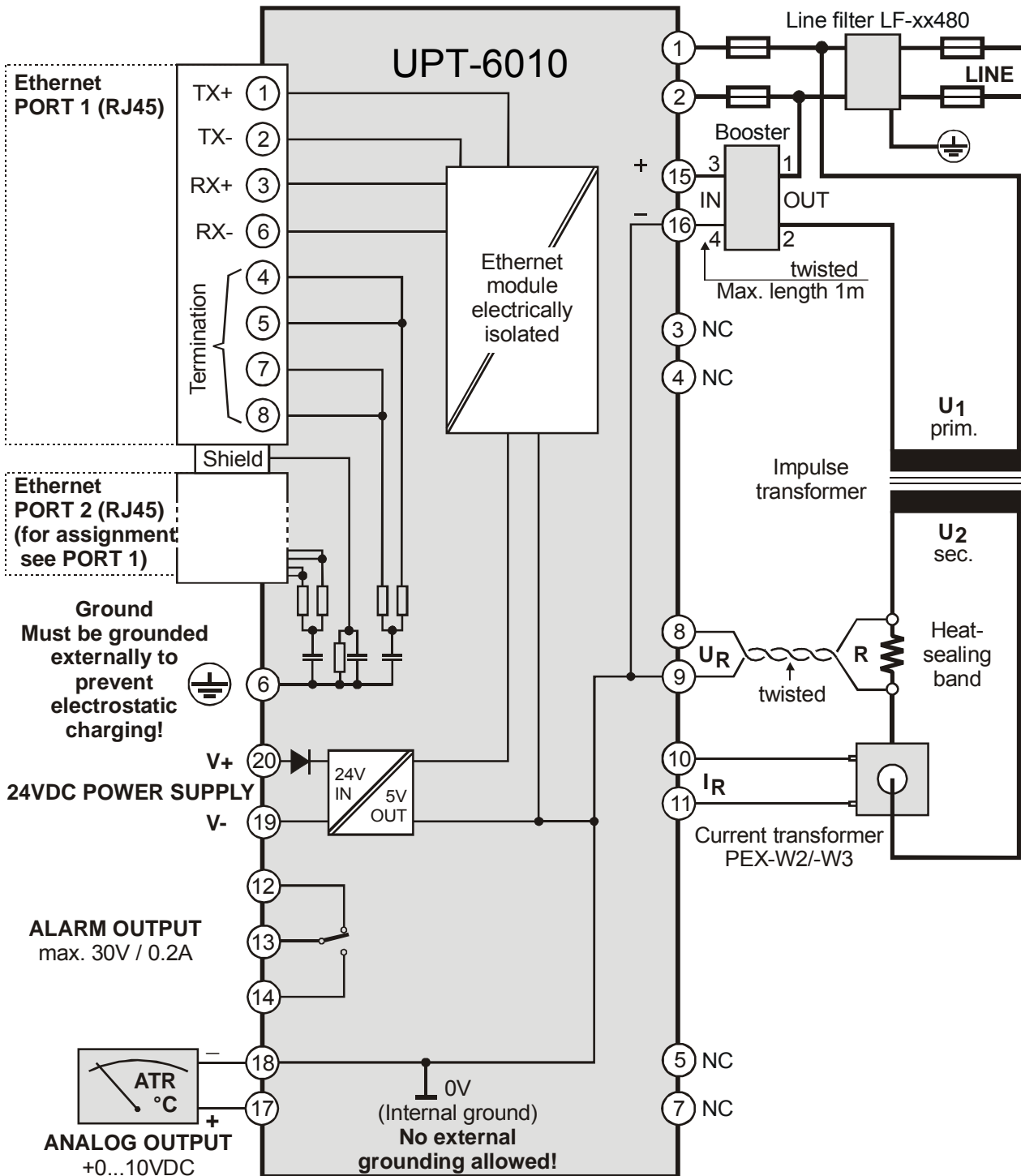

8 Startup and operation

8.1 View of the controller

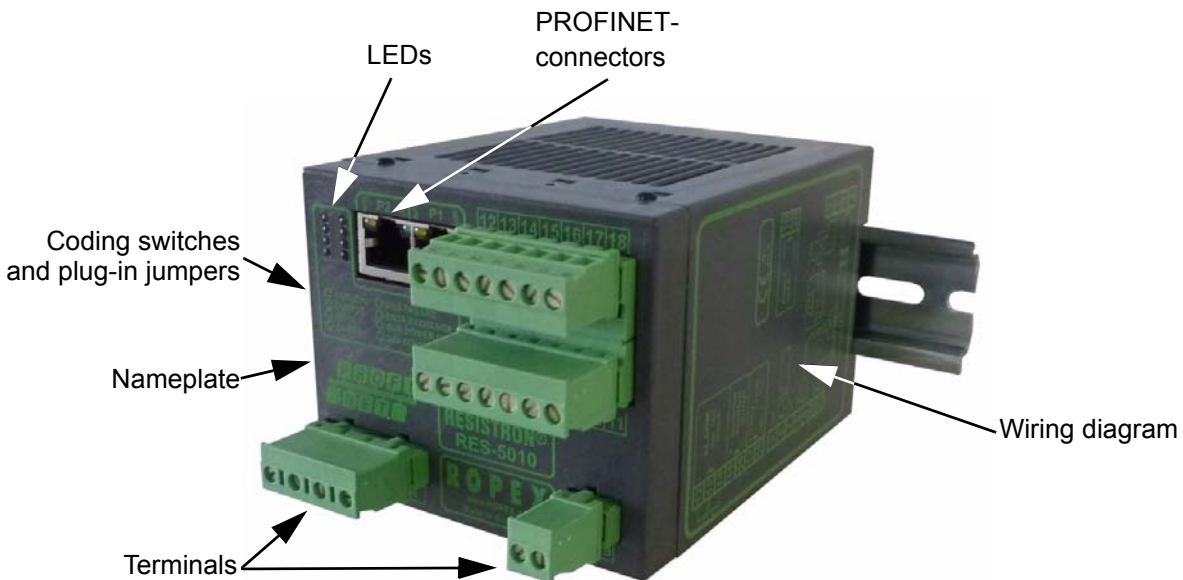

8.2 Controller configuration

⚠ The controller must be switched off in order to configure the coding switches and plug-in jumpers.

8.2.1 Configuration of the secondary voltage and current ranges

The secondary voltage and current ranges are automatically configured by the automatic calibration

function (AUTOCAL). The voltage is configured in the range from 0.4VAC to 120VAC and the current in the range from 30A to 500A. If the voltage and / or current are outside of the permissible range, a detailed error message appears on the controller (↪ see section 9.17 "Error messages" on page 37).

If the secondary current I_2 is less than 30A, the secondary high-current wire must be laid twice (or several times) through the PEX-W2 or PEX-W3 current transformer (↪ ROPEX Application Report).



8.2.2 Configuration of the rotary coding switch for the temperature range and alloy

Switch position	Temp. range	Temp. coefficient	Band alloy
0	300°C	1700ppm/K	(CIRUS)
4	500°C	1700ppm/K	(CIRUS)
9	PC-CONFIGURATION		

0 = Factory settings

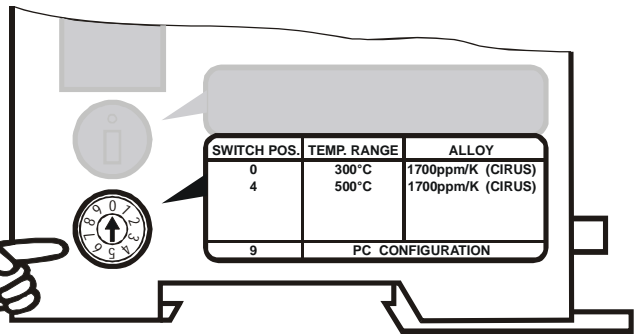
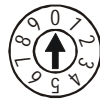

⚠ The setting of the rotary coding switch for the temperature range and alloy can be overwritten with the parameter data (see section 9.7 "Parameter data" on page 29).

If the switch is set to "9", more temperature ranges and alloys can be selected by means of the ROPEX visualization software (see section 9.11 "Diagnostic interface / visualization software" on page 34).

new setting does not take effect until the next time the controller is switched on.

The preset station name "UPT-6010" is configured as follows, depending on the settings of the rotary coding switches:

8.2.3 Configuration of the rotary coding switches for station names

These coding switches can be used to set the names of the UPT-6010 stations in the PROFINET network. A

Rotary coding switch	Station name
00	The last name assigned is static
01...FE	UPT-6010-01...UPT-6010-FE
FF	The last station name assigned and the I&M data are erased

Station name selectable.

00 = Factory settings

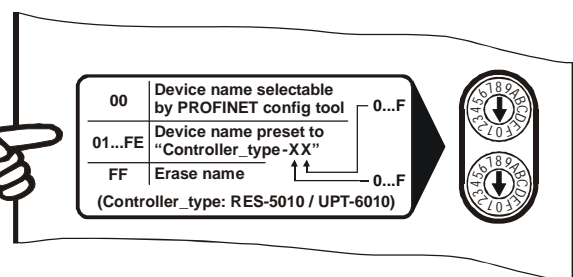
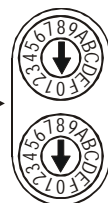
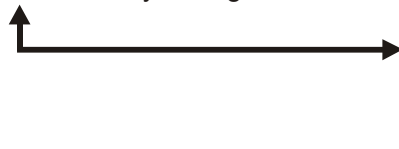

By assigning station names using rotary coding switches, it is possible to replace a device in an existing machine without a programming tool. The replacement device must simply be configured with the same switch settings.

If the UPT-6010 was named using a suitable PROFINET tool (e.g. Siemens STEP7), the preset station name can be erased by means of the rotary coding switches. To do this, make sure the controller is de-energized, then set the switches to 0xFF and switch the controller on again. It is sufficient to supply the

controller with 24VDC. No connection to the PROFINET network is required. When the station name has been successfully erased, the DATA EXCHANGE LED (red) blinks at approx. 4Hz. The power supply to the controller must then be momentarily interrupted in order for the new switch settings to take effect.

⚠ In addition to the station name, restoring the controller's factory settings by setting the

rotary coding switches to "0xFF" also erases all I&M data in the memory.

! In order to assign the station name via the PROFINET interface (e.g. using a programming tool), the rotary coding switches must be set to "0x00".

Note: By using a configuring tool (e.g. Siemens STEP7) to specify the PROFINET topology, you can also assign names automatically if the controller does not already have a station name when it is switched on. In this case, the PLC automatically assigns it the name stored in the project.

8.2.4 Configuring the fault relay

Alarm relay de-energized by alarm/ PC-CONFIGURATION.

Alarm relay energized by alarm.
(factory setting)

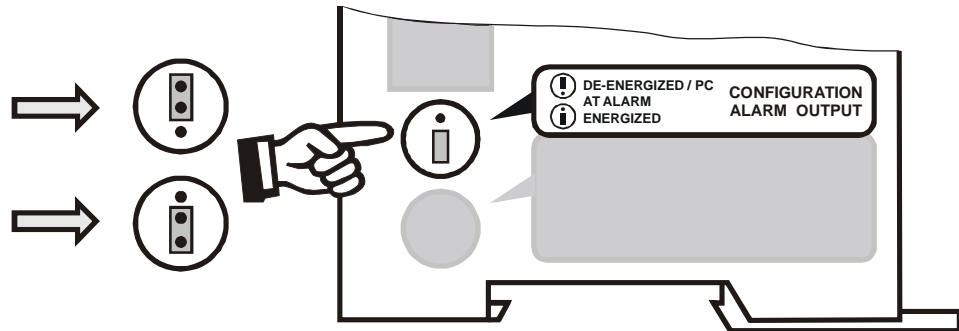

! If the jumper is not inserted – or if it is incorrectly inserted – an error message appears when the controller is switched on (↪ section 9.17 "Error messages" on page 37).

If the "Fault relay de-energized at alarm / PC CONFIGURATION" position is selected, the behavior of the alarm output can be configured in more detail by means of the ROPEX visualization software (↪ see section 9.11 "Diagnostic interface / visualization software" on page 34).

8.3 Heating element

8.3.1 General

The heating element is a key component in the control loop, since it is both a heating element and a sensor. The geometry of the heating element is too complex to be discussed at length here. We shall therefore only refer to a few of the most important physical and electrical properties:

The measuring principle applied for this system necessitates a heating element alloy with a suitable temperature coefficient TCR, i.e. one whose resistance increases as the temperature rises.

Too low a TCR leads to oscillation or uncontrolled heating.

When heating elements with a higher TCR are used, the controller must be calibrated for this.

! The base resistance of the heating elements rises continuously during operation (construction-conditioned). Due to this the AUTOCAL function must be executed every 100.000 sealing cycles for preventing measurement failures of the ACTUAL temperature.

8.3.2 Replacing the heating element

All power supply leads must be disconnected from the CIRUS temperature controller in order to replace the heating element.

! The heating element must be replaced in accordance with the instructions provided by the manufacturer.

Each time the heating element is replaced, the zero point must be calibrated with the AUTOCAL function (↪ section 9.5.1 "Automatic zero calibration "AUTOCAL" (AC)" on page 26) while the element element is still cold. The correction factor Co (↪ section 9.7.9 "Correction factor Co" on page 31) must be adjusted too. With this procedure the produc-

tion-related resistance tolerances of the heating element will be compensated.

8.4 Startup procedure

Please also refer to section 1 "Safety and warning notes" on page 3 and section 2 "Application" on page 4.

 **Installation and startup may only be performed by technically trained, skilled persons who are familiar with the associated risks and warranty provisions.**

8.4.1 Initial startup

Prerequisites: The controller must be correctly installed and connected (↪ section 7 "Installation" on page 11). Proceed as follows to start up the controller for the first time:

1. Switch off the line voltage and verify that all circuits are de-energized.
2. The supply voltage specified on the nameplate of the controller must be identical to the line voltage that is present in the plant or machine. The line frequency is automatically detected by the temperature controller in the range from 47...63Hz.
3. Link the device master file (GSDML) into the PROFINET controller (↪ section 9.3), then select the required parameters, assign a name to the device, and start the communication.
4. Make sure the "ST" bit is not set.
5. Switch on the line voltage and the 24VDC auxiliary supply (the order is arbitrary).
6. When the voltage is switched on, the yellow "AUTOCAL" LED lights up for approximately 0.3 seconds to indicate that the controller is being powered up correctly. The "BUS FAILURE" LED (red) lights up as long as no PROFINET communication is active. It does not go out again until it detects an active communication.

 **If the red "ALARM" LED lights up for 0.3s in addition to the yellow "AUTOCAL" LED when the voltage is switched on, the configuration of this controller has been changed by means of the visualization software (↪ section 9.11 "Diagnostic interface / visualization software" on page 34). In order to avoid malfunctions, please check the controller configuration before continuing the startup procedure.**

7. The green "DATA EXCHANGE" LED lights up to indicate an active PROFINET communication.
8. One of the following states then appears:

"ALARM" LED	"OUTPUT" LED	ACTION
OFF	Short pulses every 1.2s	Go to 9
BLINKS fast (4Hz)	OFF	Go to 9
LIT continuously	OFF	Error code <u>901</u> (Error group: 7): No line voltage / sync signal (↪ section 9.2) <u>Otherwise:</u> Error diagnosis (↪ section 9.17)

9. Activate the AUTOCAL function while the heating element is still cold by setting the "AC" bit (AUTOCAL) in the PROFINET protocol (↪ section 9.4 "Communication protocol" on page 25). The yellow "AUTOCAL" LED lights up for the duration of the calibration process (approx. 10...15s). The "AA" bit (AUTOCAL active) is additionally set and a voltage of approx. 0VDC appears at the actual value output (terminals 17+18). If an ATR-x is connected, it indicates 0...3°C.
When the zero point has been calibrated, the "AUTOCAL" LED goes out and a voltage of 0.66VDC (300°C range) or 0.4VDC (500°C range) appears at the actual value output instead. If an ATR-x is connected, it must be set to "Z".
If the zero point has not been successfully calibrated, the "AL" bit (alarm active) is set and the red "ALARM" LED blinks slowly (1Hz). In this case the controller configuration is incorrect (↪ section 8.2 "Controller configuration" on page 17 and ROPEX Application Report). Repeat the calibration after the controller has been configured correctly.
10. When the zero point has been successfully calibrated, specify a defined temperature by means of the PROFINET protocol (set point) and set the "ST" bit. The "RA" bit (controller active) is then activated and the "HEAT" LED lights up. The heating and control process can be observed at the actual value output.

The controller is functioning correctly if the temperature (which corresponds to the signal change at the analog output or the actual value in the PROFINET protocol) has a harmonious motion, in other words it must not jump abruptly, fluctuate, or deviate temporarily in the wrong direction. This kind of behavior would indicate that the U_R measurement cable has been laid incorrectly.

If an error message is displayed, please proceed as described in section 9.17 "Error messages" on page 37.

11. The heatup process and the temperature control must be optimized by means of setting the correction factor Co in the parameter data (GSDML file) or the acyclic services (↪ section 9.7.9 "Correction factor Co " on page 31) now. With this setting the manufacturing process related tolerances of the heating element are compensated.

The controller is now ready

9 Controller functions

See also section 7.4 "Power supply" on page 13.

9.1 LEDs and controls

RX/TX (yellow LED)	Lit or blinking if Ethernet frames are transmitted.
LINK (green LED)	Lit if connection exists to Ethernet.

BUS FAILURE (red/green LED)	Lit or blinking if no connection exists to PROFINET.
DATA EXCH (red/green LED)	Lit (green) while data exchange with PROFINET controller.
BUS PWR OK (green LED)	Lit if internal 5VDC power supply for PROFINET interface is OK.
24V SUPPLY (Green LED)	Lit if external 24VDC power supply is present.

AUTOCAL (yellow LED)	Lit while AUTOCAL process is executing.
OUTPUT (Green LED)	Indicates pulses in measurement mode. In control mode, luminous intensity is proportional to heating current.
HEAT (yellow LED)	Lit during heating phase.
ALARM (Red LED)	Lit or blinking to indicate fault.

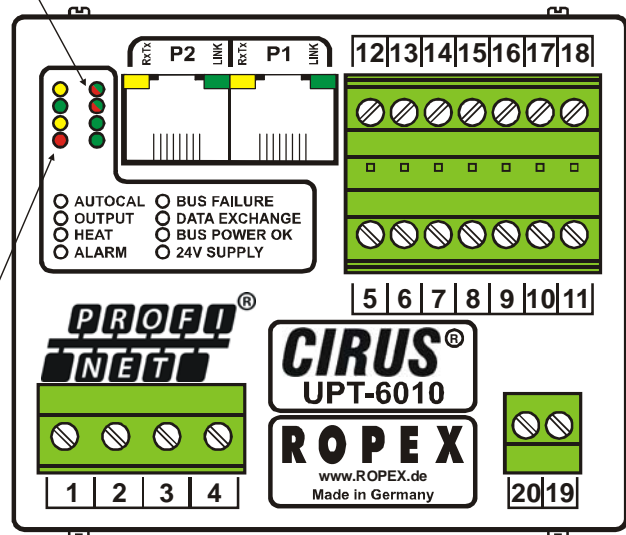

In addition to the functions shown in the diagram above, various controller operating states are indicated

by the LEDs. These states are described in detail in the table below:

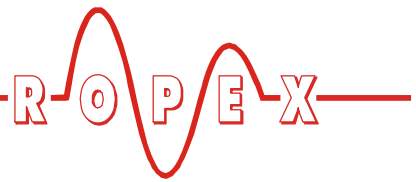

LED	BLINKS slowly (1Hz)	BLINKS fast (4Hz)	Lit continuously
AUTOCAL (yellow)	"RS" bit is set (reset)	AUTOCAL requested but function disabled (e.g. START active)	AUTOCAL executing
	LED blinks with a different frequency: Supply voltages incorrect (too low)		
HEAT (yellow)	—	START requested but function is locked (e.g. AUTOCAL active, set temperature < 40°C)	START executing
OUTPUT (green)	In control mode, the luminous intensity is proportional to the heating current		
ALARM (red)	Configuration error, AUTOCAL not possible	Controller calibrated incorrectly, run AUTOCAL	Error, ↪ section 9.17
DATA EXCHANGE (red / green)	—	Rotary coding switches for station name are set to 0xFF (factory settings restored)	Green: Communication with PROFINET controller is active Red: Internal error in PROFINET module
BUS FAILURE (red / green)	Blinks (red) for 3s at 2Hz: No data exchange Blinks (green or yellow) at 2Hz: DCP signal service activated over the bus		Red: No communication or slow / no physical connection
LINK PORT 1, 2 (green)	—	—	Connection exists to Ethernet
RX / TX PORT 1, 2 (yellow)	The device is transmitting / receiving Ethernet frames		

9.2 PROFINET communication

! The following sections describe only controller-specific functions. For general information about the PROFINET interface and the system configuration, please refer to the description of your PLC.

! The PROFINET interface of the UPT-6010 supports "Conformance Class B" with IO/RT according to IEC 61784-2. "Conformance Class C" with IO/RT is not supported.

The controller can communicate via the PROFINET interface provided the 24VDC supply voltage (terminals 19+20) is present.

! However, if the line voltage is not present (e.g. if it is switched off in order to open a door), error code 901 or 201 (error group 7, no line voltage / sync signal) appears on the controller and the fault relay is switched. This error can be reset by switching on the line voltage again and setting the "RS" bit (↪ section 9.5.3 "Reset (RS)" on page 27).

The error code that appears if the line voltage is switched off can be easily processed – and switching of the fault relay suppressed – in the PLC program.

9.3 Device master file (GSDML)

Configuring tools for the PROFINET controller that must be configured interpret the content of the device master files (GSDML) and uses it to create a parameter set for the PROFINET controller which is responsible for useful data communication. The *GSDML-V2.2-ROPEX-0150-UPT-6010-20120131.XML* file of the UPT-6010 contains all the controller information needed for the configuration, e.g. the I/O data description, parameter descriptions, error messages etc. The device master files and the associated image files (.BMP) (for visualization in the configuring tool) can be requested by e-mail (support@ropex.de) or downloaded from our website (www.ropex.de).

After the required device master file has been linked into the configuring tool, you must assign a unique name to the controller. The controller is not assigned a name at the factory. You must also select the desired parameter values.

9.4 Communication protocol

The communication protocol consists of 2x16 bit input words and 3x16 bit output words (from the point of view of the controller). This protocol separates the set point and the actual value of the UPT-6010 from the status

information and the control functions, to enable it to be decoded more easily by the PROFINET controller.



Bits 0...7 form the low byte and bits 8...15 the high byte ("INTEL format").

The 2 x 16-bit **input data** contains the set point in word ① and the control functions in word ②:

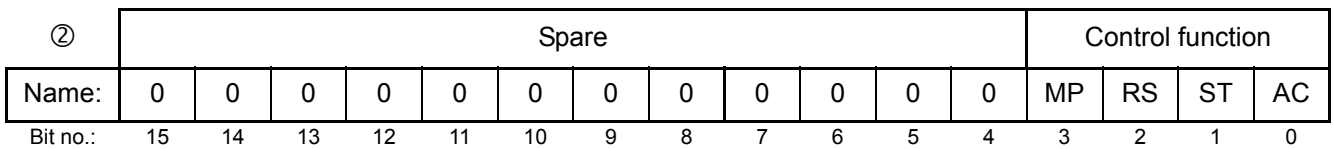
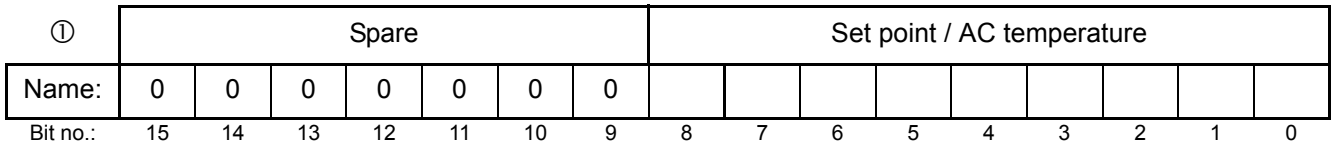

The 3 x 16-bit **output data** contains the actual value in word ①, the status information in word ②, and the error code in word ③:

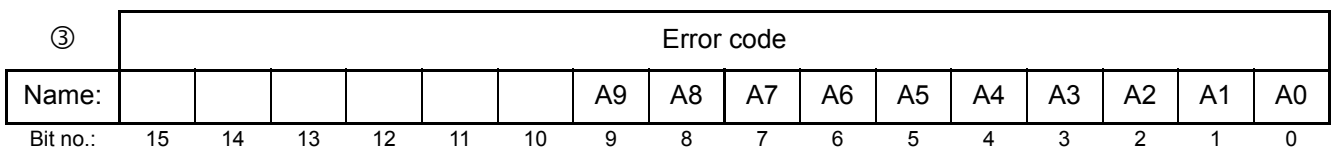
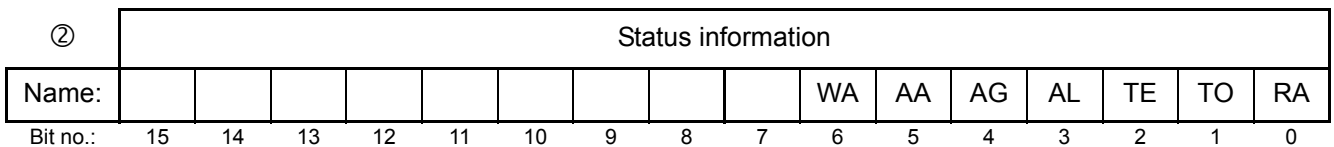
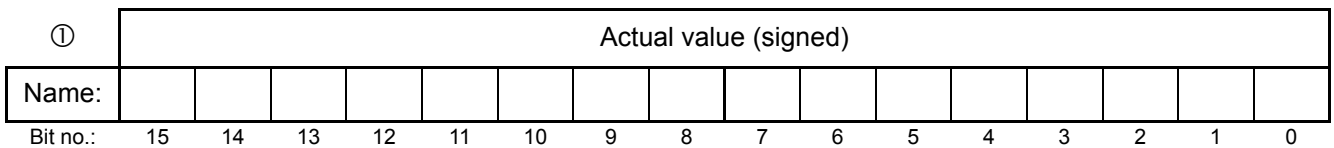

9.5 Input data

The term "input data" refers to the data that is transferred from the PROFINET controller to the

UPT-6010. It contains the set point and the control functions, such as START or AUTOCAL for the UPT-6010. These functions are explained in the following.

9.5.1 Automatic zero calibration "AUTOCAL" (AC)

Owing to the automatic zero calibration (AUTOCAL) function, there is no need to adjust the zero point manually on the controller. This function matches the controller to the current and voltage signals that are present in the system and calibrates it to the value which is predefined in the parameter data (↪ section 9.7.4 "Variable calibration temperature" on page 30). If no parameter data is transferred by the PROFINET controller, the default value is 20°C.

Some PROFINET controllers do not allow the parameter data to be changed during operation. It is therefore not possible to adapt the calibration temperature to the prevailing ambient conditions in the machines.

The calibration temperature can be specified by means of the "Set point / AC temperature" input data whenever the zero point is calibrated, provided this setting is selected in the parameter data (↪ section 9.7.4 "Variable calibration temperature" on page 30). It can be specified in the 0...+40°C range. The value selected for the calibration temperature must be entered in the "Set point / AC temperature" input data when the "AUTOCAL" function is activated ("AC" bit = 1). This selected value must remain entered until the "AUTOCAL" function has finished.

If the specified temperature is too high (greater than 40°C) or if the selected value varies, an error message appears (error codes 115 and 116; ↪ section 9.17 "Error messages" on page 37).

The AUTOCAL request ("AC" bit = 1) is executed by the controller provided the AUTOCAL function is not disabled.

The automatic calibration takes around 10...15 seconds. The heating element is not heated during this process. The yellow LED on the front panel lights up while the AUTOCAL function is active and the controller reports "AUTOCAL active" ("AA" bit = 1) in the output data. The actual value output (terminals 17+18) is 0...3°C (corresponds to approx. 0VDC).

If the temperature of the heating element varies, the "AUTOCAL" function is executed a maximum of three times. If the function still cannot be terminated successfully, an error message appears (↪ section 9.17 "Error messages" on page 37).

 **You should always wait for the heating element and the bar to cool down (to ambient temperature) before activating the "AUTOCAL" function.**

Reasons for disabled AUTOCAL function:

1. An "AUTOCAL" request cannot be processed until 10 seconds after the controller is switched on. During this time the controller reports "AUTOCAL disabled" ("AG" bit = 1) in the output data.
2. The "AUTOCAL" function is not activated if the heating element cools down at a rate of more than 0.1K/s. If the "AC" bit is set, the function is automatically executed when the cooling rate falls below the above-mentioned value.
3. If the "START" bit ("ST" bit = 1) is set, the AUTOCAL function is not executed ("HEAT" LED lit).
4. If the "RESET" bit ("RS" bit = 1) is set, the "AUTOCAL" function is not executed.
5. The "AUTOCAL" function cannot be activated if error codes 101...103, 201...203, 801 or 9xx occur at startup (↪ section 9.17 "Error messages" on page 37). It cannot be activated with error codes 201...203, 801, or 9xx if the controller has operated correctly at least once since startup.

 **If the AUTOCAL function is disabled ("AG" bit = 1) and you attempt to activate it ("AC" bit = 1), the "AUTOCAL" LED blinks fast (4 Hz).**

9.5.2 Start (ST)

When the "START" bit is set ("ST" bit = 1), the controller's internal set / actual comparison is enabled and the heating element is heated to the SET temperature. It remains at this temperature either until the "ST" bit is reset or until the actual heating time exceeds the preset heating time limit (↪ section 9.7.5 "Heating time limit" on page 30).

The "HEAT" LED on the front panel of the UPT-6010 lights up continuously for the duration of the heatup time.

A start request is not processed if the AUTOCAL function is active, the controller has reported a fault, the set point is less than 40°C or the "RS" bit is set. In all of these cases the "HEAT" LED blinks.

The heatup process is terminated if the "ST" bit is reset or if an PROFINET error is signaled.

 **The "ST" bit is only accepted if the AUTOCAL function is deactivated and there are no faults.**

The fault relay is switched if the "ST" bit is set while a warning message is indicating error codes 8...12 (104...106, 111...114, 211, 302, or 303) (↪ section 9.17 "Error messages" on page 37). The heating element is no longer heated.

9.5.3 Reset (RS)

This bit resets the controller if the controller reports a fault.

No AUTOCAL or START requests are accepted as long as the "RS" bit is set. Until it is reset again, only error codes 5 and 7 (201...203, 901, 913) are evaluated and output by the error diagnosis function. The power section is not activated in this state and no measuring impulses are generated. As a result of this, the actual value is no longer updated. The reset request is not processed until the "RS" bit is reset. The PROFINET communication is not interrupted by a controller reset. The controller simply requests the parameter data from the PROFINET controller again. The controller actual value output changes to 0...3 °C (i.e. approximately 0VDC) while the "RS" bit is being set. This may be interpreted by the higher-level controller (e.g. a PLC) as feedback.

The "AUTOCAL" function is not aborted if the "RS" bit is set while it is still executing.

! The controller performs an internal initialization lasting approximately 500ms after the "RS" bit is reset. The next heatsealing process cannot be started until it has finished.

! If a contactor Kb is used to deactivate the control loop (↪ section 7.4 "Power supply" on page 13), it must be energized again 50ms at the latest after the "RS" bit is reset. If it is energized too late, an error message will be output by the controller.

9.5.4 Measurement pause (MP)

No more measuring impulses are generated by the controller as soon as the "MP" bit is set. Until it is reset again, only error codes 5 and 7 (201...203, 901, 913) are evaluated and output by the error diagnosis function. In addition, the actual value is no longer updated. The last valid value before the bit was set is output. As soon as the bit is reset, new measuring impulses are generated, all error messages are evaluated, and the actual value is updated again. This bit is only active in measuring mode. "ST", "RS", and "AC" take priority.

The bit is suitable for all applications in which the electrical connections of the heating element need to be disconnected during normal operation without triggering a fault (e.g. sliding rail contacts).

In contrast to the "RS" bit (RESET), the "MP" bit does not reset any fault signals when it is set. The controller is activated again as soon as the bit is reset, in other words there is no initialization phase.

! When the controller is started, it only evaluates the "MP" bit if the system test (including the functional test of the heating circuit) is successful. This can take several hundred milliseconds.

9.5.5 Set point

A set point of up to 300 °C or 500 °C is allowed, depending on the selected temperature range (↪ section 9.7.1 "Temperature range and alloy" on page 30). If you attempt to enter a higher set point, it is limited internally to 300 °C or 500 °C.

9.6 Output data

The term "output data" refers to the data that is transferred from the UPT-6010 to the PROFINET controller. It contains the current actual value and all important information about the momentary status of the controller. If a fault is signaled, it can be diagnosed accurately with the help of the error code.

9.6.1 AUTOCAL active (AA)

The "AA" bit indicates that the AUTOCAL function is currently executing.

9.6.2 AUTOCAL disabled (AG)

If the "AG" bit is set, the AUTOCAL function is temporarily disabled. This is the case if "START" is active or if the heating element is still in the cooling phase.

9.6.3 Fault active (AL)

If the "AL" bit is set, a fault has been triggered but not yet reset. The error code provides information about the exact cause of the fault (↪ section 9.17 "Error messages" on page 37).

9.6.4 Warning active (WA)

This bit can be set in addition to the "AL" bit. If the "WA" bit is set, a warning is output for the current fault. In this case, the fault relay is not active.

9.6.5 Temperature reached (TE)

The "TE" bit is set if the actual temperature exceeds 95% of the set temperature. As soon as the control mode is exited ("ST" bit = 0) or a fault is signaled ("AL" bit = 1), this status bit is reset again.

9.6.6 Temperature OK (TO)

The UPT-6010 checks whether the actual temperature is within a settable tolerance band ("OK" window) either side of the set temperature. The lower ($\Delta\vartheta_{lower}$) and upper ($\Delta\vartheta_{upper}$) limits of the tolerance band can be changed independently of one another by means of the parameter data (see section 9.7 "Parameter data" on page 29). The following settings are possible:

1. "Off"

The "TO" bit is always reset.

2. "Active if Tact = Tset" (factory setting)

The "TO" bit is set if the actual value is inside the specified temperature tolerance band. If the actual temperature is outside of the tolerance band, the "TO" bit is reset (see graph below).

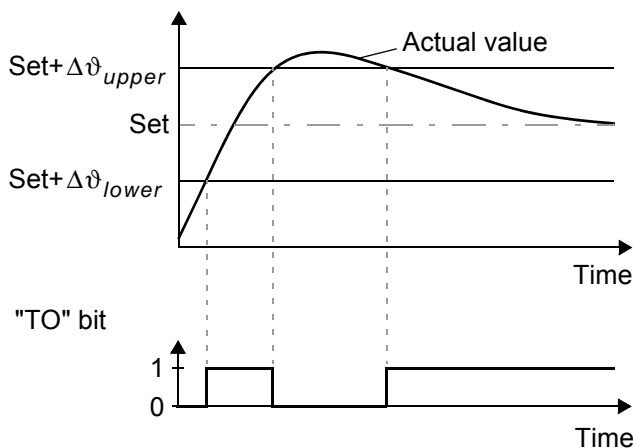

Unlike the "Temperature reached" status bit ("TE" bit), the actual temperature is evaluated independently of the control mode.

3. "Active if Tact = Tset" with latch function

A heatsealing cycle starts when the "ST" bit is set. The "TO" bit is set when the actual temperature reaches the temperature tolerance band for the first time during a heatsealing cycle. If the actual temperature leaves the tolerance band again –while the "ST" bit is still set– the "TO" bit is reset (refer to Fig.a.). If the actual temperature does not leave the tolerance band –while the "ST" bit is still set– the "TO" bit is not reset until the start of the next heatsealing cycle (latch function, refer to Fig.b.).

The switching state of the "TO" bit can thus be queried after the "ST" bit has been reset and before the start of the next heatsealing cycle.

a.) Temperature not OK

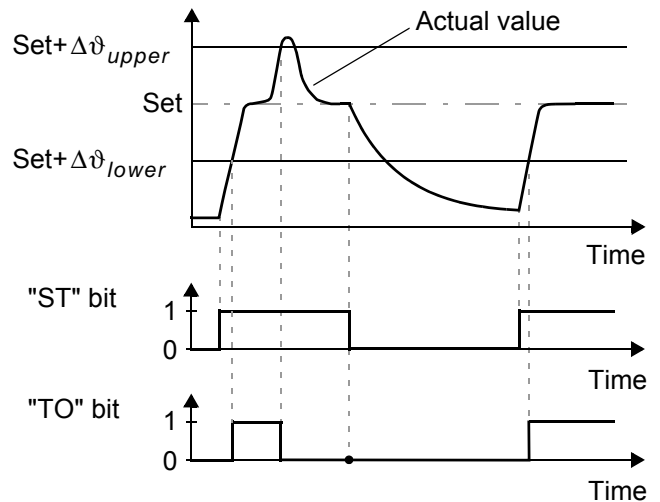

b.) Temperature OK

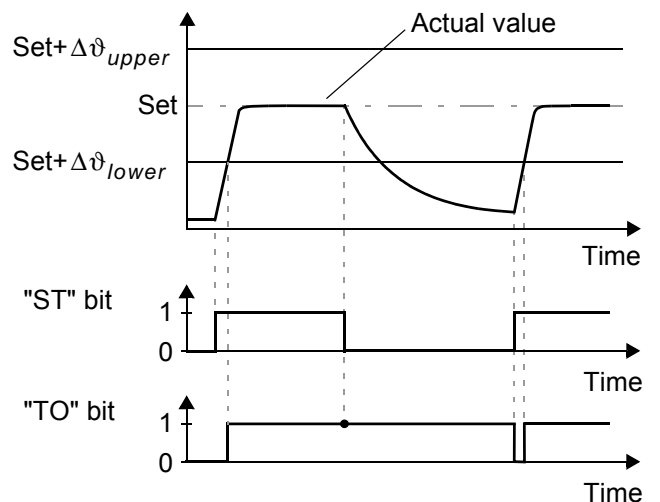

! The limits of the tolerance band are adjustable up to a maximum of +99 K.

9.6.7 Controller active (RA)

The UPT-6010 has successfully processed the "START" request and entered control mode if the "RA" bit = 1.

9.6.8 Actual value

All 16 bits of the first word must be interpreted as a signed number (twos complement notation). During the calibration procedure or if a fault is signaled, the actual value is 0.

9.6.9 Error codes

If a fault is signaled ("AL" bit = 1), the error code allows the exact cause to be determined. The error code is contained in the third word at bit positions 0...9 (↪ section 9.17 "Error messages" on page 37).

In addition to the error codes, the PROFINET diagnosis function also sends error messages to the PROFINET controller. The error messages corresponding to each error code are already stored in the device master file (GSDML), so that they automatically appear in plain text on the PROFINET controller whenever the device diagnosis for the UPT-6010 is queried there. The error messages are stored in the GSDML file in English and German. You can select the required language in the configuration tool.

9.7 Parameter data

The parameter data contains values for selecting the heating element alloy, the temperature range, the upper and lower tolerance band limits for temperature monitoring, the calibration temperature, and the optional heating time limit. It is transferred from the PROFINET controller to the UPT-6010 each time the system is started up. The parameters can also be queried by the PROFINET controller or sent by it to the UPT-6010 at any time by means of asynchronous read/write services. They are not stored in the UPT-6010. The parameter data can be addressed at slot 1, subplot 1, starting at index 4 and has the following structure:

Index	Function	De- fault value ¹	Value range
4	Temperature range / alloy	10	0, 1, 4, 5, 8, 10, 11 (↪ 9.7.1)
5	Lower temperature OK threshold	10K	3...99K
6	Upper temperature OK threshold	10K	3...99K
7	Calibration temperature	20°C	-1, 0...40°C
8/9	Heating time limit (100ms steps)	0	0...999 (0...99.9s)

Index	Function	De- fault value ¹	Value range
10	External module / channel errors	On	Off, on
11	Measuring impulse duration	17	17...30 (1.7...3.0ms)
12	Data format	Little Endian (Intel)	Little Endian (Intel), Big Endian (Motorola)
13	Correction factor	100%	25...200 (25...200%)
14/15	Temperature coefficient	1100p pm/K	400...400 0ppm/K
16/17	Maximum start temperature	100°C	20...500 (20...500°C)
18	Temperature range	300°C	200, 300, 400, 500°C
19/20	Maximum temperature	300°C	200...500° C
21	Temperature diagnosis	Off	Off, on
22/23	Temperature diagnosis delay time (100 ms steps)	0 s	0...999 (0...9.99s)
24/25	Heatup timeout (100ms steps)	0 s	0...999 (0...99.9s)
26	Temperature OK bit	Active if Tact=Tset	Off, active if Tact=Tset, active if Tact=Tset with latch
27	Hold mode	Off	Off, on, 2s

1. The default value is stored in the device master file (GSDML) and transferred from the PROFINET controller to the UPT-6010 when the system is started up.

9.7.1 Temperature range and alloy

This parameter selects both the temperature range and the heating element alloy. You can overwrite the setting of the rotary coding switch by changing the default value (10) (↪ section 8.2.2 "Configuration of the rotary coding switch for the temperature range and alloy" on page 18).

Value	Temperature range	Alloy
0	300°C	TCR = 1700ppm/K, e.g. CIRUS
4	500°C	TCR = 1700ppm/K, e.g. CIRUS
9	PC configuration (ROPEX visualization software)	PC configuration (ROPEX visualization software)
10	Rotary coding switch setting	Rotary coding switch setting
11	Variable: Parameter index 18 is used	Variable: Parameter index 14/15 is used

Setting 11 applies the value stored in parameter index 18 to the temperature range and the value stored in parameter instance 14/15 to the alloy.

 **You must always execute the AUTOCAL function after changing the "Temperature range/alloy", "Temperature range", or "Temperature coefficient" parameter.**

9.7.2 Lower temperature OK threshold

Lower threshold value for the "OK" window. Refer to section 9.6.6 "Temperature OK (TO)" on page 28 and section 9.7.11 "Temperature diagnosis" on page 31.

9.7.3 Upper temperature OK threshold

Upper threshold value for the "OK" window. Refer to section 9.6.6 "Temperature OK (TO)" on page 28 and section 9.7.11 "Temperature diagnosis" on page 31.

9.7.4 Variable calibration temperature

The calibration temperature is set to 20°C as default. You can change it to another value between 0°C and 40°C in order to adapt it to the temperature of the cold heating element.

Some PROFINET controllers do not allow the parameter data to be changed during operation. It is therefore not possible to adapt the calibration temperature to the prevailing ambient conditions in the machines.

The calibration temperature can be activated for setting by means of the input data by selecting the value "-1" in the parameter data. The calibration temperature can then be specified via the "Set point / AC temperature" input data (↪ section 9.5.1 "Automatic zero calibration "AUTOCAL" (AC)" on page 26).

 **You do not need to execute the AUTOCAL function after changing the calibration temperature.**

9.7.5 Heating time limit

The heating time limit provides additional protection against unwanted permanent heating. The controller automatically deactivates the heating impulse after the set heating time limit has elapsed if the start bit remains set for longer than the time specified by this limit. The start bit must be reset before the controller can be started up again.

The heating time limit is activated as default (value 5.00s) but can be set to any value between 0s and 9.99s (0 and 999).

9.7.6 External module / channel errors

The controller diagnosis uses the diagnostic function of the PROFINET protocol to display several errors of the UPT-6010 directly on the PROFINET controller. There is a text message stored in the device master file (GSDML) for each error which is automatically displayed in plain text on the PROFINET controller provided the controller has this capability.

The display of external module / channel errors can be activated or deactivated by means of the parameter at index 9. The default setting for external module / channel errors is "on".

You can query the controller status by means of the user data regardless of this parameter.

9.7.7 Measuring impulse duration

The length of the measuring impulses generated by the controller can be set by means of the parameter at

index 10. It may be necessary to set a measuring impulse that is longer than the default 1.7 ms for certain applications.

9.7.8 Data format

This parameter specifies the order of the bytes ("Little Endian (Intel)", "Big Endian (Motorola)") in the cyclic data for both input and output data (↪ section 9.4 "Communication protocol" on page 25). We recommend setting "Big Endian (Motorola)" for Siemens PLCs.

9.7.9 Correction factor Co

The correction factor Co permits the UPT-6010 controller to be adapted to the real conditions in the machine (type of UPT heating element, impulse transformer specification, length of connecting wires, cooling etc.).

Proceed as follows to determine the optimum correction factor Co (setting in step 6):

1. Controller settings:
 - Set temperature: 160...180°C
 - sealing time: 0.20...0.30s
2. Activate sealing pulses ("ST" bit = 1)
Refer to section 9.5.2 "Start (ST)" on page 26.

Slowly increase the correction factor – starting either with the lowest value (50%) or with the value recommended in the ROPEX Application Report minus 25% – to the indicated hold value = set temperature.

The correction factor should be checked, and if necessary corrected, whenever the machine is operated or the set temperature or the heatsealing time are changed.

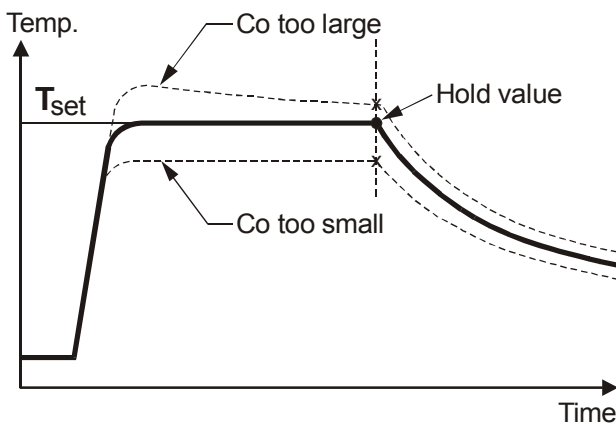

9.7.10 Maximum starting temperature

In the PROFINET parameter data the maximum starting temperature can be adjusted. This temperature is the maximum permissible actual value at the start time. The value is determined by the controller at the start of each impulse and compared with the preset value. This function serves to monitor the cooling circuit.

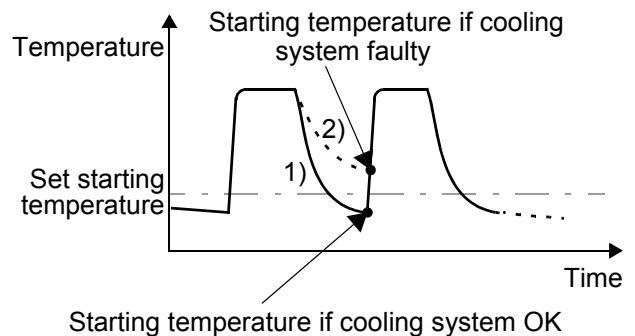

If the cooling system is intact, the tool is cooled down according to curve 1). If the cooling system is faulty, it is cooled down according to curve 2) because the water is no longer cooled. As a result, the temperature is always at least the value set with this menu step. In this case, the controller ignores the next heating command and reports an alarm. The corresponding error code 305 is indicated and the fault output is switched (↪ section 9.17 "Error messages" on page 37). This prevents the UPT sealing bar from being damaged beyond repair.

⚠ The maximum value of the setting range is limited either by the value for the maximum temperature or by the temperature range. Both values are preset in the PROFINET parameter data.

Setting:

We advise you not to set this parameter until you have determined the optimum heatsealing parameters (temperature and cooling time) for productive operation. The starting temperature should be set to approximately 50% of the heatsealing temperature for the trial run, to enable the optimum working parameters to be established correctly.

9.7.11 Temperature diagnosis

An additional temperature diagnosis can be activated by means of the PROFINET parameter data (GSDML file). The UPT-6010 checks whether the ACTUAL temperature is within a settable tolerance band ("OK" window) on either side of the SET temperature. The lower ($\Delta\vartheta_{lower}$) and upper ($\Delta\vartheta_{upper}$) tolerance

band limits are the same like in the „Temperature OK“ function (↪ section 9.6.6 "Temperature OK (TO)" on page 28). The limits are configured in the factory to -10K and +10K.

If the actual temperature is inside the specified tolerance band when the "START" signal is activated, the temperature diagnosis is activated as well. If the ACTUAL temperature leaves the tolerance band, the corresponding error code (307 or 308) is indicated and the alarm relay is switched (↪ section 9.17 "Error messages" on page 37).

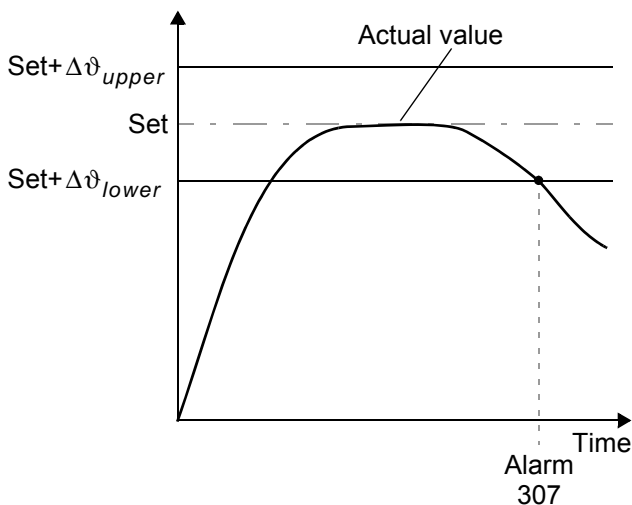

If the temperature diagnosis is not activated by the time the "START" bit is deactivated (i.e. if the ACTUAL temperature does not exceed the upper or lower tolerance band limit), the corresponding error code (309, 310) is indicated and the alarm relay is switched.

An additional delay time (0...9.99s) can be set by means of the PROFINET parameter data (GSDML file). The first time the lower tolerance band limit is exceeded, the temperature diagnosis is not activated until the parameterized delay time has elapsed. The temperature diagnosis function can thus be explicitly deactivated, e.g. if the temperature drops temporarily owing to the closure of the sealing jaws.

⚠ The lower and upper tolerance band limits cannot be set in the ROPEX visualization software. The same limits apply as for the TO bit. They can only be set by means of the PROFINET parameter data (↪ section 9.7 "Parameter data" on page 29).

9.7.12 Heatup timeout

An additional heatup timeout can be activated by means of the PROFINET parameter data (GSDML file).

This timeout starts when the „START“ bit is activated. The UPT-6010 then monitors the time required for the ACTUAL temperature to reach 95% of the SET temperature. If this time is longer than the parameterized time, the corresponding error code (304) is indicated and the alarm relay is switched (↪ section 9.17 "Error messages" on page 37).

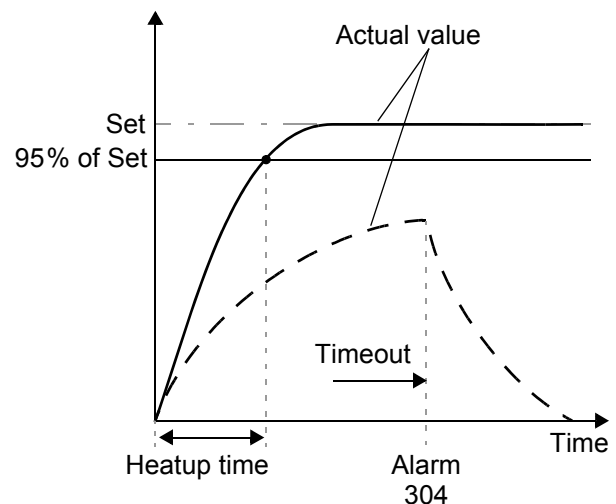

⚠ The "Heatup timeout" function must be activated by means of the PROFINET parameter data (↪ section 9.7 "Parameter data" on page 29). (default setting: Heatup timeout off)

9.7.13 Hold mode

The behavior of the ACTUAL temperature indication via the PROFINET protocol can be configured by means of the parameter data (device master file) as follows:

1. **"Off" (factory setting)**
The ACTUAL temperature is always indicated in real time.
2. **"On"**
The ACTUAL temperature that was valid at the end of the last heatsealing phase is always indicated. When the controller is switched on, the real ACTUAL temperature is indicated until the end of the first heating phase.
3. **"2 s"**
This setting causes the current ACTUAL temperature to be displayed for an additional 2 seconds at the end of a heatsealing phase by means of the PROFINET protocol. The ACTUAL temperature is then indicated again in real time until the end of the next heatsealing phase.

! Hold mode only applies to the ACTUAL temperature indication via the PROFINET communication and the digital temperature display in the ROPEX visualization software. It has no effect on the ACTUAL temperature that appears at the controller's analog output or is recorded in the graphics window of the ROPEX visualization software.

The various hold modes are shown below:

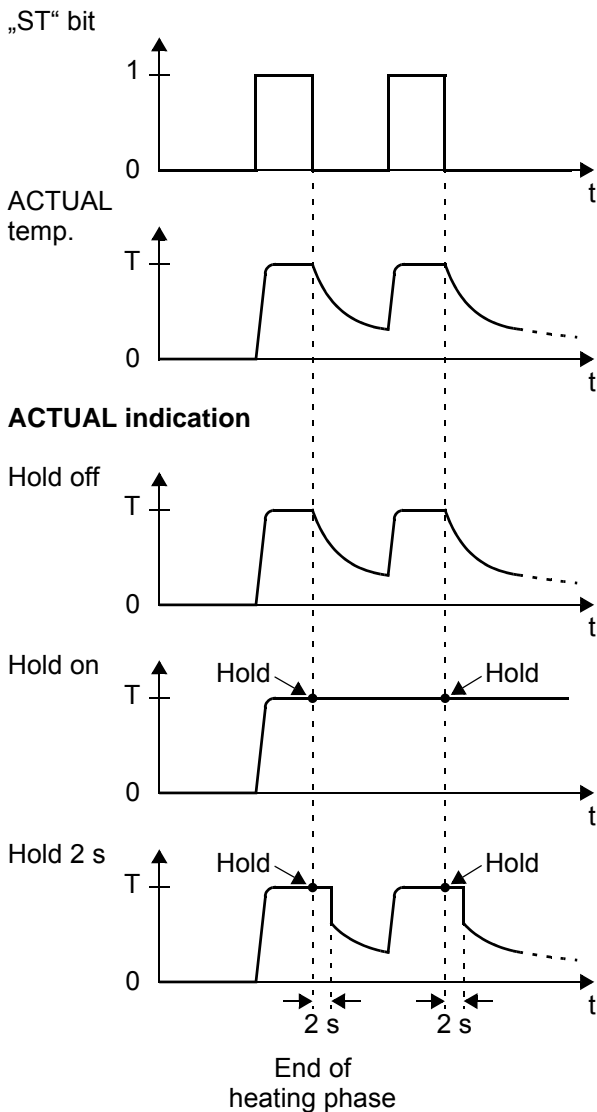

! The "hold mode" function must be activated by means of the PROFINET parameter data (↪ section 9.7 "Parameter data" on page 29). (Default setting: Hold mode off)

9.8 Undervoltage detection

Trouble-free operation of the temperature controller is guaranteed within the line voltage and 24VDC supply voltage tolerances specified in section 5 "Technical data" on page 8.

If the 24VDC supply voltage drops below the permitted lower limit, the controller is switched to standby mode. No more heatsealing processes take place and no more measuring impulses are generated. Normal operation is resumed when the input voltage returns to the specified tolerance range again.

Standby mode is indicated by 0...3 °C (i.e. approx. 0V) at the analog output.

! Trouble-free operation of the controller is only guaranteed within the specified tolerance range of the input voltage. An external voltage monitor must be connected to prevent defective heatseals due to low line or 24VDC supply voltage.

9.9 Temperature indication (actual value output)

The UPT-6010 supplies an analog 0...10VDC signal, which is proportional to the real ACTUAL temperature, at terminals 17+18.

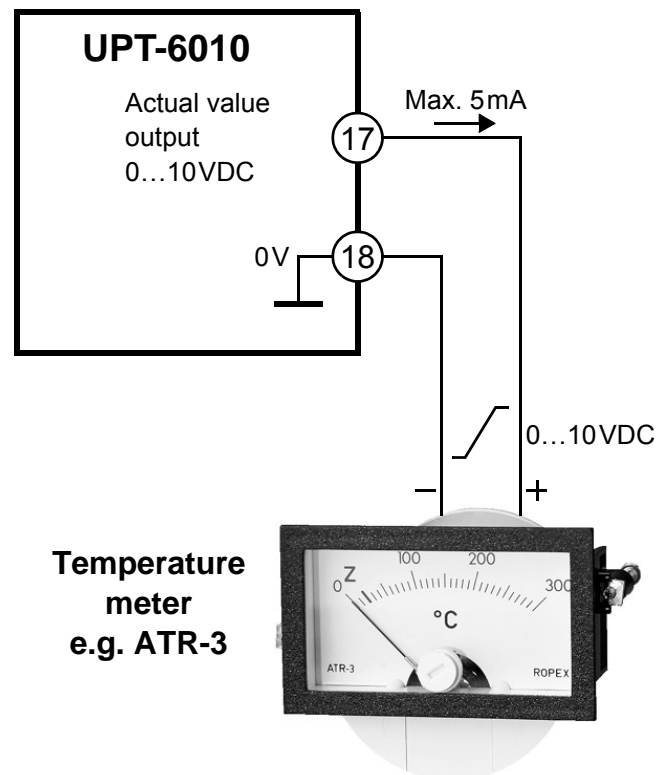

Voltage values:

0VDC → 0°C

10VDC → 300°C or 500°C

(depending on the controller configuration).

The relationship between the change in the output voltage and the ACTUAL temperature is linear.

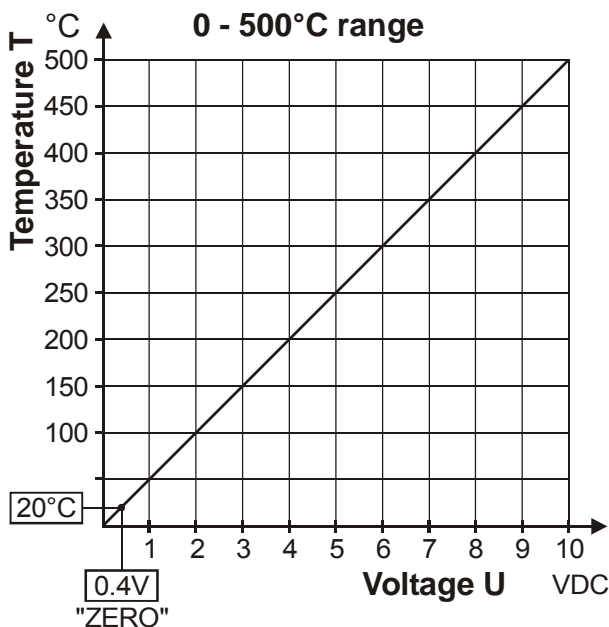
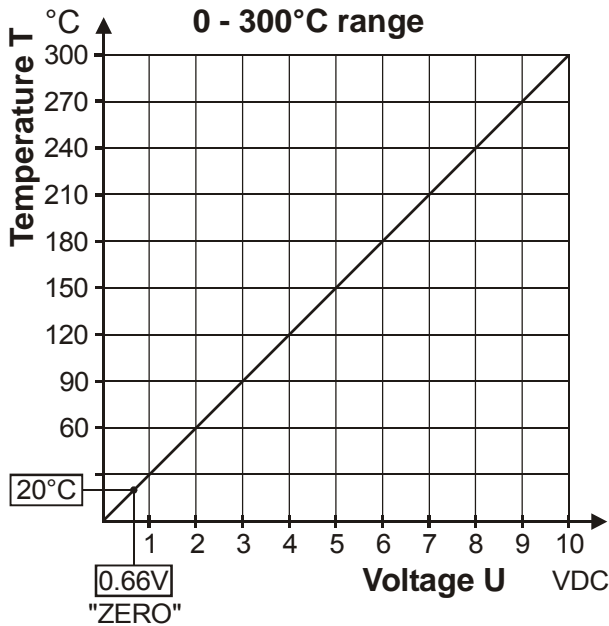

An indicating instrument can be connected to this output in order to visualize the temperature of the heating element.

The characteristics of the ROPEX ATR-x temperature meter (size, scaling, dynamic response) are ideally

suited to this application and this instrument should therefore always be used (see section 4 "Accessories and modifications" on page 6).

The meter not only facilitates SET-ACTUAL comparisons but also enables other criteria such as the heating rate, set point reached within the specified time, cooling of the heating element etc. to be evaluated.

The temperature meter additionally permits disturbances in the control loop (loose connections, contacting or wiring problems) as well as any line disturbances to be observed extremely effectively and interpreted accordingly. The same applies if mutual interference occurs between several neighboring control loops.

⚠ This output is not potential-free and could carry the secondary voltage of the impulse transformer. External grounding is not allowed. If this warning is ignored, the controller will be damaged by frame currents. Contact voltage protection must be installed at the terminals of the external temperature meter.

If a fault is signaled, this analog output is used to display a selective error message (see section 9.17 "Error messages" on page 37).

9.10 Booster connection

The UPT-6010 controller has a connection for an external switching amplifier (booster) as standard. This connection (at terminals 15+16) is necessary for high primary currents (continuous current > 5A, pulsed current > 25A). The switching amplifier should be connected as described in section 7.8 "Wiring diagram with booster connection" on page 16.

⚠ The connecting cable to the external switching amplifier must not be longer than 1 m; it must also be twisted in order to reduce EMC interference to a minimum.

9.11 Diagnostic interface / visualization software

An interface with a 6-pole Western socket is provided for system diagnostics and process visualization. This interface allows a data connection to be set up to the

ROPEX visualization software using the ROPEX CI-USB-1 communication interface.

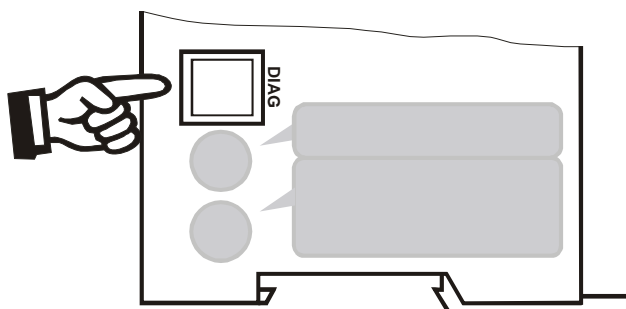

⚠ Only a ROPEX communication interface is allowed to be connected to the diagnostic interface. Connecting another device (e.g. a telephone cable) could result in malfunctions or damage to the controller.

The ROPEX visualization software is described in a separate document.

9.12 Total cycle counter

The number of heatsealing cycles executed since the controller was first delivered is stored internally ("ST" bit = 1). This counter can only be displayed and not reset. It can only be displayed using the ROPEX visualization software (↪ section 9.11 "Diagnostic interface / visualization software" on page 34).

9.13 Operating hours counter

The number of operating hours since the controller was first delivered is stored internally. This counter works with a resolution of six minutes. It can only be displayed and not reset. It can only be displayed using the ROPEX visualization software (↪ section 9.11 "Diagnostic interface / visualization software" on page 34).

9.14 Data memory for error messages and AUTOCAL

To simplify error diagnoses during operation, the UPT-6010 controller has a data memory for error messages (↪ section 9.17 "Error messages" on page 37) and executed AUTOCAL functions (↪ section 9.5.1 "Automatic zero calibration "AUTOCAL" (AC)" on page 26).

The 200 most recent messages are stored. They can be read out and displayed using the ROPEX visualization software (↪ section 9.11 "Diagnostic interface / visualization software" on page 34).

The UPT-6010 also features an integrated clock (↪ section 9.15 "Integrated clock (date and time)" on page 35). All messages are saved in the data memory together with their date and time of occurrence (time stamp).

9.15 Integrated clock (date and time)

The UPT-6010 has an integrated clock. All messages are saved in the data memory (↪ section 9.14 "Data memory for error messages and AUTOCAL" on page 35) together with their date and time of occurrence (time stamp). Error messages can thus be interpreted more accurately, for instance in order to analyze a problem.

The integrated clock can only be set and read out using the ROPEX visualization software (↪ section 9.11 "Diagnostic interface / visualization software" on page 34).

⚠ The clock is operated by means of a maintenance-free capacitor. There is no battery that has to be replaced.

The controller must remain switched on for at least three hours to make sure the clock's capacitor is fully charged. When the controller is switched off, the fully charged capacitor can keep the clock running for approx. 4...6 weeks. If the controller is switched off for longer, the date and time will have to be set again. You do this using the ROPEX visualization software (↪ section 9.11 "Diagnostic interface / visualization software" on page 34).

⚠ The capacitor is not charged when it leaves the factory. When the controller is started up, you must set the clock if you want error messages in the data memory (↪ section 9.14 "Data memory for error messages and AUTOCAL" on page 35) to be saved together with their date and time of occurrence.

⚠ The controller can also be operated without setting the clock. In this case, the date and time values that are saved in the data memory will not be valid (↪ section 9.14 "Data memory for error

messages and AUTOCAL" on page 35). **This has no effect on the temperature control functions.**

9.16 System monitoring / alarm output

To increase operational safety and avoid faulty heatsealing, this controller incorporates special hardware and software features that facilitate selective error detection and diagnosis. Both the external wiring and the internal system are monitored.

These features assist the operator in identifying the cause of abnormal conditions.

A system fault is reported or differentiated by means of the following indications.

A.) Red "ALARM" LED on the controller with three states:

1. **BLINKS fast (4Hz):**

The AUTOCAL function should be executed (error codes 104...106, 211, 302, 303).

2. **BLINKS slowly (1 Hz):**

The system configuration is incorrect and the zero calibration (AUTOCAL function) was unsuccessful (↪ section 8.2 "Controller configuration" on page 17). This corresponds to error codes 111...114).

3. **Lit continuously:**

A fault is preventing the controller from being started (error codes 101...103, 107, 108, 201...203, 304, 305, 307, 308, 9xx).

As a rule, this refers to an external wiring fault.

B.) Fault relay (relay contact terminals 12+13+14):

This relay is set at the factory as follows:

- **DE-ENERGIZED** in operating states A.1 and A.2 but energized if a "START" signal is present in one of these states.
- **ENERGIZED** in operating state A.3.

If the fault relay has the opposite configuration to the factory setting (↪ section 8.2.4 "Configuring the fault relay" on page 19), these states are reversed.

C.) Error code indicated via the PROFINET protocol

If an error occurs, the "AL" bit is set and possibly also the "WA" bit. The error code is contained in the third

word at bit positions 0...9 (↪ section 9.6.9 "Error codes" on page 29).

D.) Error code indicated via the actual value output 0...10VDC (terminals 17+18):

Since a temperature indication is no longer necessary if a fault occurs, the actual value output is used to display error messages in the event of a fault.

Thirteen voltage levels are available for this purpose in the 0...10VDC range, each of which is assigned an error code (↪ section 9.17 "Error messages" on page 37).

If a state that requires AUTOCAL occurs – or if the controller configuration is not correct – (error codes 104...106, 111...114, 211, 302, 303), the signal at the actual value output jumps back and forth at 1Hz between the voltage value corresponding to this error and the end of the scale (10VDC, i.e 300°C or 500°C). If the "ST" bit is set in one of these states, the voltage value does not change any more.

Selective fault detection and indication can thus be implemented simply and inexpensively using the analog input of a PLC with a corresponding error message (↪ section 9.17 "Error messages" on page 37).

If there is a ROPEX analog temperature meter (i.e ATR-x) connected to the analog output of the controller, then the displayed temperature can be matched directly with the error code in case of an alarm. The table below shows the correlation between voltage level, displayed temperature und error code.

Temperature range 300°C [°C]	Temperature range 500°C [°C]	Act. value output voltage [V]	Error code
20	33	0,66	1
40	66	1,33	2
60	100	2,00	3
80	133	2,66	4
100	166	3,33	5
120	200	4,00	6
140	233	4,66	7
↵ 160 ↵ ↵ 300 ↵	↵ 266 ↵ ↵ 500 ↵	↵ 5,33 ↵ ↵ 10 ↵	8
↵ 180 ↵ ↵ 300 ↵	↵ 300 ↵ ↵ 500 ↵	↵ 6,00 ↵ ↵ 10 ↵	9

Temperature range 300°C [°C]	Temperature range 500°C [°C]	Act. value output voltage [V]	Error code
↺ 200 ↻ ↺ 300 ↻	↺ 333 ↻ ↺ 500 ↻	↺ 6,66 ↻ ↺ 10 ↻	10
↺ 220 ↻ ↺ 300 ↻	↺ 366 ↻ ↺ 500 ↻	↺ 7,33 ↻ ↺ 10 ↻	11
↺ 240 ↻ ↺ 300 ↻	↺ 400 ↻ ↺ 500 ↻	↺ 8,00 ↻ ↺ 10 ↻	12
↺ 260 ↻ ↺ 300 ↻	↺ 433 ↻ ↺ 500 ↻	↺ 8,66 ↻ ↺ 10 ↻	13

 An error message can only be reset by setting the "RS" bit or by momentarily interrupting the power to the controller (24VDC supply voltage).

 If an error message is reset using the "RS" bit, it is not reset until the "RS" bit is reset.

 Invalid error messages may appear when the controller is switched off owing to the undefined operating state. This must be taken into account when they are evaluated by the higher-level controller (e.g. a PLC) in order to avoid false alarms.

9.17 Error messages

In addition to the error diagnosis which is coded in the protocol, you can also access the PROFINET diagnosis function (extended controller diagnosis). The error codes appear in the configuring tool in plain text because they are stored in the device master file.

The table below shows the meaning of the error codes. It includes a description of each error and the required corrective action.

The block diagram in section 9.18 "Fault areas and causes" on page 40 enable a particular error to be cleared quickly and efficiently.

Thirteen voltage levels for diagnosing errors appear at the controller's actual value output. The error messages are differentiated even more finely in the controller. The 3-digit error numbers described below can be displayed via the PROFINET interface and using the ROPEX visualization software (↪ section 9.11 "Diagnostic interface / visualization software" on page 34) to facilitate troubleshooting.

 If the actual value output is evaluated in order to identify an error message – in the higher-level controller, for instance – the tolerance window must be adjusted to prevent it from being incorrectly interpreted. Please note the tolerances of the actual value output (↪ section 5 "Technical data" on page 8).

Teil 1 von 3: Error messages (faults)

NOTE: The specified error messages are initially output as faults (stable error voltage level at the actual value output; alarm LED lit continuously; alarm relay is energized).

Error code		Act. value output; Voltage [V]	Caus	Action if machine started for first time	Action if machine already operating, HS band not chang.
1	101	0,66	I _R signal missing	Fault area ①	Fault area ①
2	102	1,33	U _R signal missing	Fault area ③	Fault area ③
3	103	2,00	U _R and I _R signals missing	Fault area ②	Fault areas ②⑨
4	107	2,66	Temperature step down	Fault areas ④⑤⑥ („loose contact“)	Fault areas ④⑤⑥ („loose contact“)
	108		Temperature step up		
	307		Temperature too low/high (↪ section 9.7.2)		
	308				
	309				
	310				
5	201	3,33	Line frequency is missing	Check power supply	Check power supply
	202		Line frequency too high/fluctuates		
	203		Line frequency too low/fluctuates		
6	304	4,00	Heatup time too long (↪ section 9.7.12)	Run RESET	Run RESET
	305		Start temperature too high (↪ section 9.7.10)		
7	901	4,66	No line voltage/Sync-Sig.	↪ section 9.2	↪ section 9.2
	913		Triac defective	Replace controller	Replace controller
	914		Internal fault, controller defective	Replace controller	Replace controller
	915				
	916				
	917		Plug-in jumper for alarm output wrong	Check Plug-in jumper	Check Plug-in jumper
918					

Teil 2 von 3: Error messages (warnings)

NOTE: The specified error messages are initially output as warnings (actual value output jumps back and forth between two values; alarm LED blinks; alarm relay is de-energized). When the "START" signal is activated, the warning changes to a fault (actual value output no longer jumps back and forth, see **bold italic values**; alarm LED lit continuously; alarm relay is energized).

Error code	Act. value output; Voltage [V]	Caus	Action if machine started for first time	Action if machine already operating, HS band not chang.
8	104	I _R signals incorrect, incorrect specification of impulse-transformer	Run AUTOCAL , Check specification of transformer, Fault areas ⑦⑧	Fault areas ④⑤⑥ (loose contact)
	105	U _R signals incorrect, incorrect specification of impulse-transformer		
	106	U _R and/or I _R signals incorrect, incorrect specification of impulse-transformer		
	302	Temperature too low, AUTOCAL wasn't performed, loose contact, ambient temp. fluctuates	Run AUTOCAL and/or fault areas ④⑤⑥ (loose contact)	
	303	temperature too high, AUTOCAL wasn't performed, loose contact, ambient temp. fluctuates		
9	↔ 6,00 ↔ ↔ 10 ↔	Data error	Run AUTOCAL	Run AUTOCAL

Teil 3 von 3: Error messages (warnings)

NOTE: The specified error messages are initially output as warnings (actual value output jumps back and forth between two values; alarm LED blinks; alarm relay is de-energized). When the "START" signal is activated, the warning changes to a fault (actual value output no longer jumps back and forth, see **bold italic values**; alarm LED lit continuously; alarm relay is energized).

Error code	Act. value output; Voltage [V]	Cause	Action if machine started for first time	Action if machine already operating, HS band not chang.
10 111	<i>6,66</i> ↔ 10 ↔	I _R signal incorrect, calibration not possible	Fault area ⑧, check configuration	Fault areas ④ ⑤ ⑥ (loose contact)
11 112	<i>7,33</i> ↔ 10 ↔	U _R signal incorrect, calibration not possible	Fault area ⑦, check configuration	Fault areas ④ ⑤ ⑥ (loose contact)
12 113	<i>8,00</i> ↔ 10 ↔	U _R and I _R signals incorrect, calibration not possible	Fault areas ⑦ ⑧, check configuration	Fault areas ④ ⑤ ⑥ (loose contact)
13	<i>8,66</i> ↔ 10 ↔	Temperature fluctuates, calibration not possible	Run AUTOCAL and/or Fault areas ④ ⑤ ⑥ (loose contact)	Run AUTOCAL and/or Fault areas ④ ⑤ ⑥ (loose contact)
		Ext. calibration temperature too high, calibration not possible	Run AUTOCAL with external calibration temperature ≤40°C	Run AUTOCAL with external calibration temperature ≤40°C
		Ext. calibration temperature fluctuates, calibration not possible	Run AUTOCAL with stabil external calibration temperature	Run AUTOCAL with stabil external calibration temperature

9.18 Fault areas and causes

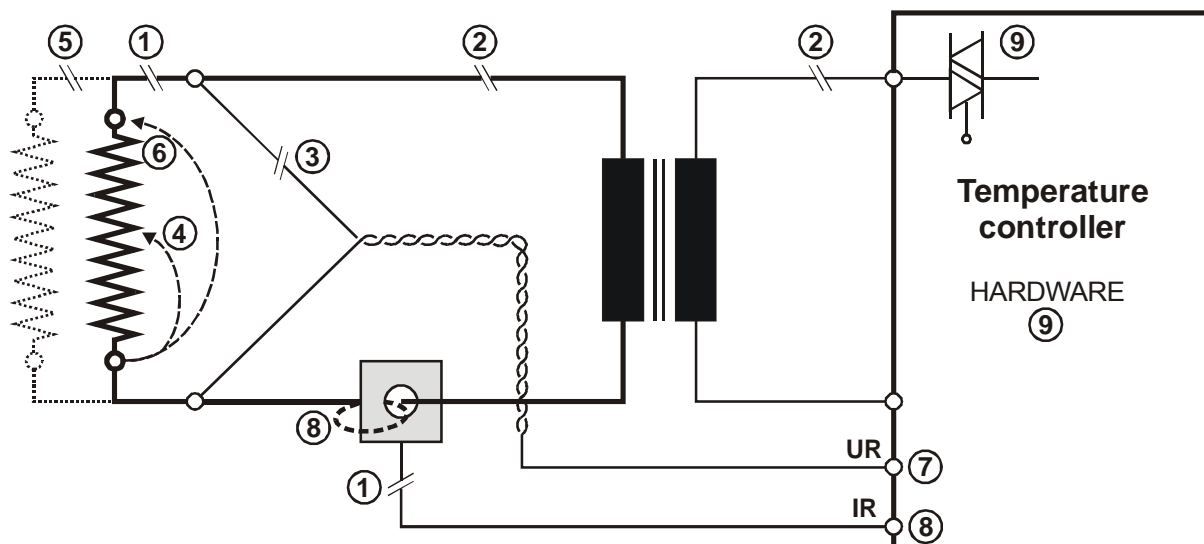



The table below explains the possible fault causes.

Fault area	Explanation	Possible causes
①	Load circuit interrupted after U_R pickoff point	- Wire break, heating element break - Contact to heating element is defective
	PEX-W2/-W3 current transformer signal interrupted	- I_R measurement cable from current transformer interrupted
②	Primary circuit interrupted	- Wire break, triac in controller defective - Primary winding of impulse transformer interrupted
	Secondary circuit interrupted before U_R pickoff point	- Wire break - Secondary winding of impulse transformer interrupted
③	No U_R signal	- Measurement cable interrupted
④	Partial short-circuit (delta R)	- Heating element partially bypassed by conducting part (clamp, opposite heating bar etc.)
⑤	Parallel circuit interrupted	- Wire break, heating element break - Contact to heating element is defective
⑥	Total short-circuit	- Heating element installed incorrectly, no insulation at heating bar ends or insulation incorrectly installed - Heating element completely bypassed by conducting part
⑦	U_R signal incorrect	- U_2 outside of permissible range from 0.4...120VAC
⑧	I_R signal incorrect	- I_2 outside of permissible range from 30...500A
	Turns through PEX-W2/-W3 current transformer incorrect	- Check number of turns (two or more turns required for currents < 30A)
⑨	Internal controller error / no line voltage	- Hardware fault (replace controller) - Jumper for fault relay not connected or incorrectly connected - No line voltage

10 Factory settings

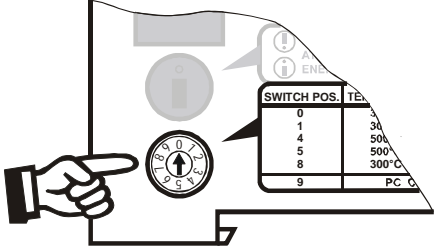
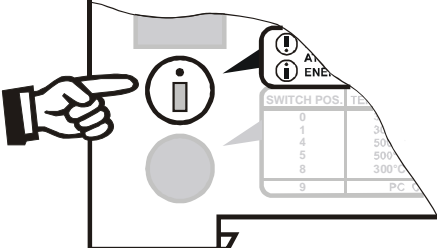
The UPT-6010 CIRUS temperature controller is configured at the factory as follows:







<p><u>Rotary coding switch</u> for heating element alloy and temperature range</p>		<p>Heating element alloy: Alloy A20 Temperature range: 300 °C</p> <p>Rotary coding switch: „0“ position</p>
<p><u>Jumper</u> for fault relay</p>		<p>Fault relay is energized at alarm</p>
<p><u>Temperature diagnosis</u></p>		<p>Temperatur diagnosis: Off</p>
<p><u>Heatup timeout</u></p>		<p>Heatup timeout: Off</p>

11 Maintenance

The controller requires no special maintenance. Regular inspection and / or tightening of the terminals – including the terminals for the winding connections on

the impulse transformer – is recommended. Dust deposits on the controller can be removed with dry compressed air.

12 How to order

	<p>Contr. RES - 6010 / . . . V AC</p> <p>↳ 400: Power supply 400VAC, Art. No. 7501003</p> <p>Scope of supply: Controller includes connector plug-in parts (without current transformer)</p> <p>Modification MOD . . (optional, if required)</p> <p>↳ e.g. 01: MOD 01, Art. No. 800001 (amplifier for low voltage)</p> <p>Please indicate the article numbers of the controller and the required modifications (optional) in all orders, e.g. UPT-6010/400VAC + MOD 01 (controller for 400VAC power supply with amplifier for low voltage) Art Nos. 7501003 + 800001 must be ordered</p>
	<p>Current transformer PEX-W3 Art. No. 885105</p>
	<p>Line filter LF- . . 480</p> <p>↳ 06: Continuous current 6A, 480VAC, Art. No. 885500 35: Continuous current 35A, 480VAC, Art. No. 885506</p>
	<p>Impulse transformer</p> <p>See ROPEX Application Report for design and ordering information</p>
	<p>Communication interface CI-USB-1 Art. No. 885650</p>
	<p>Temp. meter ATR - .</p> <p>↳ 3: 300°C range, Art. No. 882130 5: 500°C range, Art. No. 882150</p>
	<p>Booster B- . . . 400</p> <p>↳ 075: Max. pulse load 75A, 400VAC, Art. No. 885301 100: Max. pulse load 100A, 400VAC, Art. No. 885304</p>

13 Index

Numbers

24VDC supply voltage 8

A

"AA" bit 27
 "AC" bit 26
 Actual value 28
 Actual value output 33
 "AG" bit 27
 "AL" bit 20, 27
 Alarm output 36
 Alloy 18
 Ambient temperature 9
 Analog temperature meter 6
 Application 4
 Application Report 11, 14
 AUTOCAL 20
 Active 27
 Disabled 26, 27
 Starting 26
 Automatic zero calibration 20, 26

B

Booster 6, 7, 16, 43
 Booster connection 34

C

Circuit-breaker 13
 CI-USB-1 7, 35, 43
 Clock 35
 Co correction factor 31
 Communication interface 7, 35, 43
 Controller active 28
 Correction factor Co 31
 Current transformer 3, 6, 7, 14, 43

D

Data format 31
 Data memory 35
 Date 35
 Degree of protection 9
 Device master file (GSDML) 24
 Diagnostic interface 34
 Digital temperature meter 7
 Dimensions 10

E

Error messages 37
 Extended controller diagnosis 30
 External switching amplifier 7

F

Factory settings 42

Fault 27
 Fault diagnosis 6
 Fault relay 8, 19
 Fuse 13

G

GSDML file 24

H

Heating element 3, 19
 Heating element type 8
 Heating time limit 30
 Heatup timeout 32

I

Impulse transformer 3, 7, 13, 43
 Input data 25
 Installation 9, 11
 Installation procedure 11
 Installation regulations 12
 Installationsvorschriften 11

L

Line filter 3, 7, 13, 14, 43
 Line frequency 8
 Line voltage 8

M

Maintenance 42
 Measurement cable 7
 Measurement pause 27
 Measuring impulse duration 30
 Measuring range 8
 Modification MOD 43
 Modifications (MODs) 7
 MODs 7
 Monitoring current transformer 7
 "MP" bit 27

O

Operating hours counter 35
 Output data 27
 Over-current protection 13

P

PEX-W2/-W3 3, 6
 PEX-W3 14, 43
 Power dissipation 9
 Power supply 13
 Power supply system 8
 PROFINET interface 8

R

"RA" bit 20, 28
Replacing the heating element 19
Reset 27
"RS" bit 27

S

Set point 27
Standby mode 33
Start 26
"START" bit 20
Starting temperature 31
Startup and operation 17
System diagnosis 34
System monitoring 36

T

TCR 19
"TE" bit 28

Temperature coefficient 19
Temperature diagnosis 31
Temperature meter 6, 34, 43
Temperature OK 28
Temperature range 8, 18
Temperature reached 28
Time 35
Time stamp 35
"TO" bit 28
Total cycle counter 35
Transformer 3, 7, 13, 43
Type of construction 8

V

Visualization software 34, 35

W

Wiring 12, 13