

CIRUS

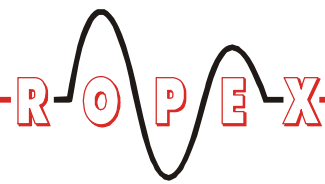

UPT-6011

Operating instructions



21.7.16

ROPEX

Industrie-Elektronik GmbH
Adolf-Heim-Str. 4
D-74321-Bietigheim-Bissingen

Tel.: +49 (0)7142-7776-0
Fax: +49 (0)7142-7776-211

E-Mail: info@ropex.de
Internet: www.ropex.de
Data subject to change

Contents

1	General information	3	6	Device functions	16
1.1	Intended use	3	6.1	LEDs and controls	16
1.2	Heating element	3	6.2	EtherNet/IP™ communication	18
1.3	Impulse transformer	3	6.3	Device description file (EDS)	18
1.4	Current transformer PEX-W2/-W3/-W4	3	6.4	Communication protocol	19
1.5	Line filter	3	6.5	Input data	19
1.6	Standards / CE marking	4	6.6	Output data	21
1.7	Maintenance	4	6.7	Parameter object (class: 0x0F)	23
1.8	Disposal	4	6.8	Integrated web server	41
2	Application	4	6.9	Undervoltage detection	43
3	System description	5	6.10	Temperature meter(actual value output)	43
3.1	Temperature controller	5	6.11	Booster connection	44
3.2	Booster	6	6.12	USB interface for visualization software (ROPEXvisual®)	44
4	Mounting and installation	7	6.13	AUX interface	45
4.1	Installation procedure	7	6.14	Total cycle counter	45
4.2	Installation steps	7	6.15	Operating hours counter	45
4.3	Power supply	8	6.16	Data memory for error messages and AUTOCAL	45
4.4	Line filter	9	6.17	Built-in clock (date and time)	45
4.5	Current transformer PEX-W3/-W4	9	6.18	System monitoring / alarm output	46
4.6	Wiring diagram (standard)	10	6.19	Error messages	46
4.7	Wiring diagram with booster connection	11	6.20	Fault areas and causes	50
5	Startup and operation	12	7	Factory settings	51
5.1	View of the device	12	8	Technical data	53
5.2	Device configuration	12	9	Dimensions	55
5.3	Heating element	14	10	Accessories and modifications	55
5.4	Startup procedure	14	10.1	Accessories	55
			10.2	Modifications (MODs)	56
			11	How to order	57
			12	Index	58

1 General information

This CIRUS temperature controller is manufactured according to DIN EN 61010-1. In the course of its manufacture it passed through quality assurance, whereby it was subjected to extensive inspections and tests. As a result of this, the product left our factory in perfect condition.

The recommendations and warning notes contained in these operating instructions must be complied with, in order to guarantee safe operation.

The device can be operated within the limits indicated in the "Technical Data" without impairing its operational safety. Installation and maintenance may only be performed by technically trained, skilled persons who are familiar with the associated risks and warranty provisions.

1.1 Intended use

CIRUS temperature controllers may only be used for heating and temperature control of heatsealing elements which are expressly approved for them, and providing the regulations, notes and warnings contained in these instructions are observed.

In case of non-observance or use contrary to the intended purpose, there is a risk that safety will be impaired or that the heatsealing element, electrical wiring, transformer etc. will overheat. This is the personal responsibility of the user.

1.2 Heating element

The temperature coefficient of a CIRUS temperature controller is specially adapted to CIRUS heating elements.

 **The controller is not allowed to be operated with any other heatsealing bands because they could be overheated and damaged beyond repair.**

1.3 Impulse transformer

A suitable impulse transformer is necessary in order to guarantee trouble-free operation of the control loop. This transformer must be designed according to VDE 0570 / EN 61558 (isolating transformer with reinforced insulation) and have a one section bobbin. When the impulse transformer is installed, suitable touch protection must be provided in accordance with the national installation regulations for electrical equipment. In addition to this, water, cleaning solutions and conductive fluids must be prevented from seeping into the transformer.

Incorrect installation of the impulse transformer impairs electrical safety.

1.4 Current transformer PEX-W2/-W3/-W4

The current transformer supplied with the CIRUS temperature controller is an integral part of the control system.

Only the original ROPEX PEX-W2, PEX-W3 or PEX-W4 current transformer may be used. Other transformers may cause the equipment to malfunction.

The current transformer may only be operated if it is correctly connected to the CIRUS temperature controller (see section "Startup and operation"). The relevant safety instructions contained in section "Power supply", must be observed. External monitoring modules can be used in order to additionally increase operating safety. They are not included in the scope of supply of the standard control system and are described in a separate document.

1.5 Line filter

The use of an original ROPEX line filter is mandatory in order to comply with the standards and provisions mentioned in section 1.6 "Standards / CE marking" on page 4. This device must be installed and connected according to the instructions contained in section "Power supply" as well as the separate documentation enclosed with the line filter.

1.6 Standards / CE marking

The controller described here complies with the following standards, provisions and directives:

DIN EN 61010-1:2001 (2014/35/EU)	Safety requirements for electrical equipment for measurement, control and laboratory use (low-voltage directive): pollution degree 2, protection class I, measurement category I (for U_R and I_R terminals)
DIN EN 60204-1 (2006/42/EG)	Electrical equipment of machines (machinery directive)
EN 55011:2009+A1:2010 EN 61000-3-2:2006-04+ A1:2009+A2:2009 EN 61000-3-3:2008 EN 61000-6-4:2007+ A1:2011 (2014/30/EU)	EMC genery emissions: Group 1, Class A
EN 61000-6-2:2005 (2014/30/EU)	EMC generic immunity: Class A (ESD, RFI, burst, surge) <u>Exception:</u> Line voltage interruption acc. EN 61000-4-11 is not fulfilled (This leads to a designated error message of the controller)

Compliance with these standards and provisions is only guaranteed if original accessories and / or peripheral components approved by ROPEX are used. If not, then the equipment is operated on the user's own responsibility.

The CE marking on the controller confirms that the device itself complies with the above-mentioned standards.

It does not imply, however, that the overall system also fulfils these standards.

2 Application

This CIRUS temperature controller is an integral part of the "6000" series. Its sole purpose is to control the temperature of CIRUS / UPT heating elements, which are mainly used for impulse-heatsealing PP and PE films.

It is the responsibility of the machine manufacturer and of the user to verify the completely installed, wired and operationally ready system in the machine with regard to its conformity with the safety provisions and the EMC directive (see also section "Power supply"). If peripheral components (e.g. the transformer or the line filter) from other manufacturers are used, no functional guarantee can be provided by ROPEX.

1.7 Maintenance

The controller requires no special maintenance. Regular inspection and / or tightening of the terminals – including the terminals for the winding connections on the impulse transformer – is recommended. Dust deposits on the controller can be removed with dry compressed air.

1.8 Disposal

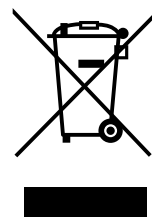

This device is subject to Directive 2012/19/EU concerning the reduction of the increasing amount of waste electrical and electronic equipment and the disposal of uch waste in an environmentally sound way.

It must not be disposed of as residual wase! To guarantee proper disposal and / or the recover of reusable material, please take the device to adesignated municipal collectin point and observe local regulations.

Careless, uncontrolled disposal can cause damage to thenvironment and human health. By ensuring that yourproduct is disposed of or recycled in a responsible way, you can help protect the environment and human health.

3 System description

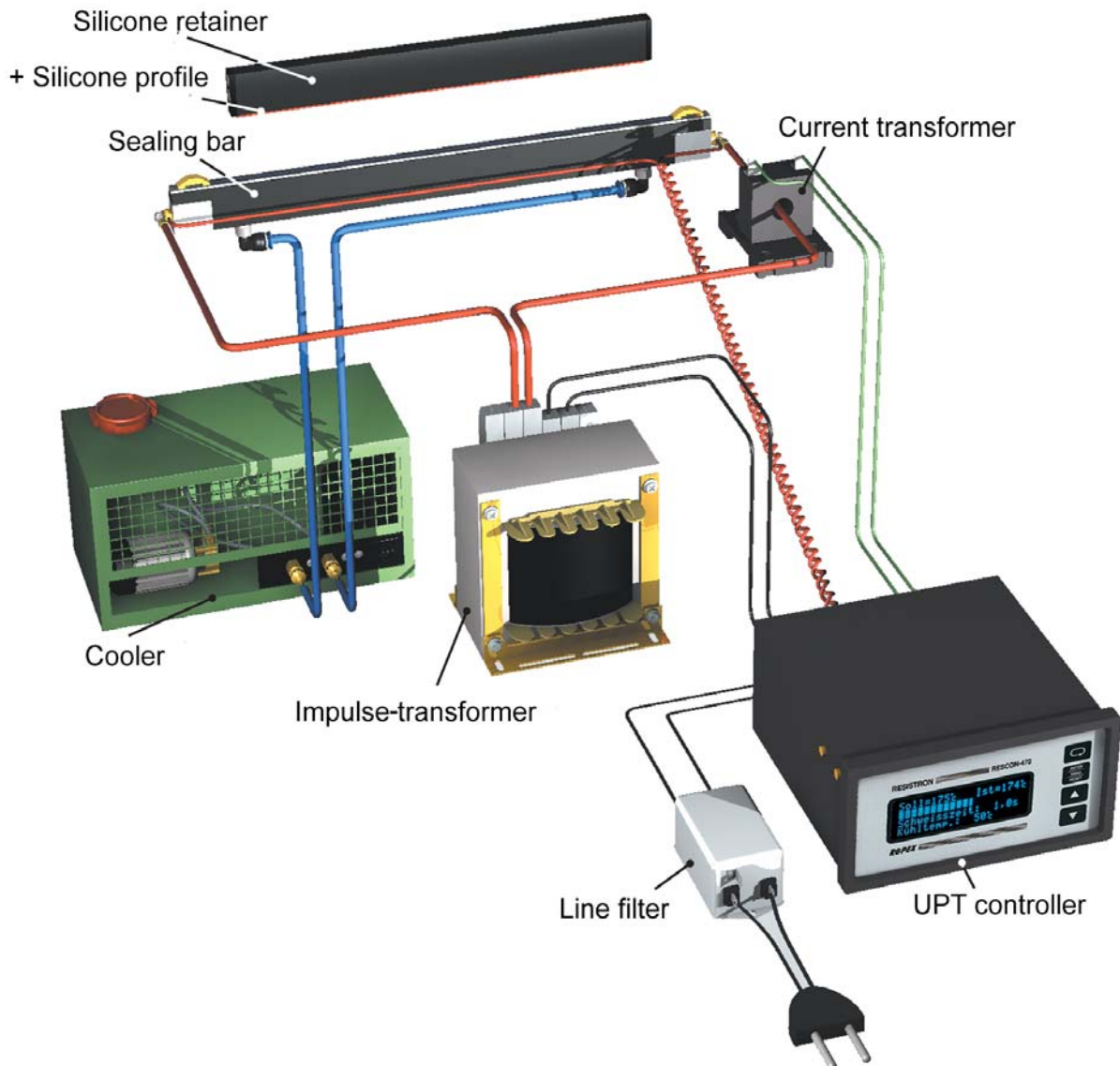

The diagram above shows the basic structure of the overall system.

CIRUS heating elements, and in particular UPT heating elements, are high performance systems which operate efficiently and reliably provided all of the components in the control loop are fully compatible with one another – and optimally adapted to the task at hand. The installation and wiring instructions must be strictly observed. The system was put together and optimized by ROPEX GmbH in an intensive development process. By observing our technical recommendations, you can profit from the optimized functionality of this technology, which reduces the effort for installation, startup, and maintenance to a minimum.

3.1 Temperature controller

The controller determines the resistance of the heating element by measuring the current and voltage at a high sampling rate (line frequency), compares it with the set point and – if the difference is not 0 – adjusts the heating current with the help of a phase controlled transformer so that set = actual.

A highly dynamic thermoelectric control loop is established in this way because purely electrical variables

are measured in rapid succession and the heating layer of the UPT heating element has a small mass.

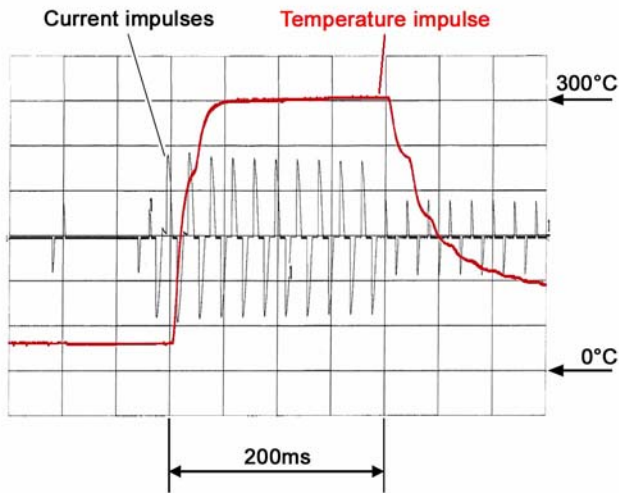

Thanks to the microprocessor based technology, the controller has an optimized control algorithm as well as numerous functions tailored to specific tasks such as "AUTOCAL", ALARM with error diagnosis etc. These are described in detail below.

The CIRUS temperature controller UPT-6011 is equipped with two EtherNet/IP™ interfaces. These interfaces can be used to control all of the controller functions and query controller information.

The ACTUAL temperature of the heatsealing band is supplied to the EtherNet/IP™ interface and to an analog 0...10VDC output. The real temperature of the UPT heating element can thus be visualized on an external indicating instrument (e.g. ATR-x).

The UPT-6011 features an integrated error diagnosis function, which checks both the external system (heating element, wiring etc.) and the internal electronics and outputs a selective error message in the event of a fault.

To increase operational safety and interference immunity, all EtherNet/IP™ signals are electrically isolated from the controller and the heating circuit.

The compact design of the CIRUS UPT-6011 temperature controller and the plug-in terminals make it very easy to mount and install.

3.2 Booster

If the load current exceeds the rated current of the controller (↪ section 8 "Technical data" on page 53), an external switching amplifier (booster) must be used (↪ section 10 "Accessories and modifications" on page 55).

The other system components – UPT sealing bars, transformers, filter, water chiller etc. – are described in separate brochures.

4 Mounting and installation

↪ See also section 1 "General information" on page 3.

! Mounting, installation and startup may only be performed by authorized persons who have received suitable instruction and are familiar with the associated risks and warranty provisions.

4.1 Installation procedure

Proceed as follows to install the CIRUS UPT-6011 temperature controller:

1. Switch off the line voltage and the 24 VDC supply, and verify that the circuit is de-energized.
2. The supply voltage indicated on the nameplate of the CIRUS temperature controller must be identical to the line voltage that is present in the system or machine. The line frequency is automatically detected by the RESISTRON temperature controller in the range from 47 Hz to 63 Hz.
3. Mount the CIRUS temperature controller on a standard top hat rail (DIN TS35 rail according to DIN EN 50022) in the electrical cabinet. If several controllers are mounted on one rail, the minimum clearance specified in section 8 "Technical data" on page 53 must be allowed between them.
4. Wire the system in accordance with the instructions in section 4.3 "Power supply" on page 8, section 4.6 "Wiring diagram (standard)" on page 10, and the ROPEX Application Report. The information provided in section 4.3 "Power supply" on page 8 must also be observed.

Wires used for control or measuring connections must always be laid inside the building.

5. An overcurrent protective device with a maximum rating of 10A must be fitted when the device is installed, e.g.:
 - Miniature circuit breaker to EN 60898 (B, C, D, K, or Z characteristic)
 - Miniature circuit breaker to UL 489 (*) (B, C, D, K, or Z characteristic)
 - Fuse gG to IEC 60269
 - Class CC or Class J fuse to UL 248 (*)

The overcurrent protective devices marked (*) should be used in installations conforming to UL standards.

If one such device is not adequate for the

heatsealing application, two separate overcurrent protective devices should be provided – one for the controller and one for the application (↪ ROPEX Application Report).

The overcurrent protective device must be located directly adjacent to the controller.

The minimum possible specification for this device is indicated in the ROPEX Application Report based on the calculated currents. If a larger overcurrent protective device is fitted, you must match the current carrying capacity of the other components accordingly (e.g. cables, impulse transformer etc.).

6. A disconnecting device must be provided when the system is installed; it must be marked as belonging to the system and fitted in a readily accessible position. If a miniature circuit breaker is used, it can also perform the function of this device.
7. Connect the CIRUS temperature controller to the EtherNet/IP™ scanner using a suitable (standard compliant) cable.

! Check that all system connections – including the terminals for the impulse transformer windings – are securely attached.

8. Make sure the wiring conforms to all relevant national and international installation regulations.

4.2 Installation steps

1. Please refer to the safety and warning notes (↪ section 1 "General information" on page 3).
2. The information provided in the customized ROPEX Application Report, which is specifically prepared by ROPEX for each application, must be observed.
3. All electrical components such as the controller, impulse transformer, and line filter, should be installed as close as possible to the UPT sealing bar(s) in order to avoid unnecessarily long cables.
4. Connect the voltage measurement cable U_R directly to the UPT sealing bar and lay it twisted to the controller (for the UML-1 voltage measurement cable, see ↪ section 10 "Accessories and modifications" on page 55).
5. Ensure an adequate cable cross-section for the primary and secondary circuits (↪ Application Report).
6. Use only ROPEX impulse transformers or trans-

formers approved by ROPEX. Please note the power, duty cycle, and primary and secondary voltages (☞ Application Report).

4.3 Power supply

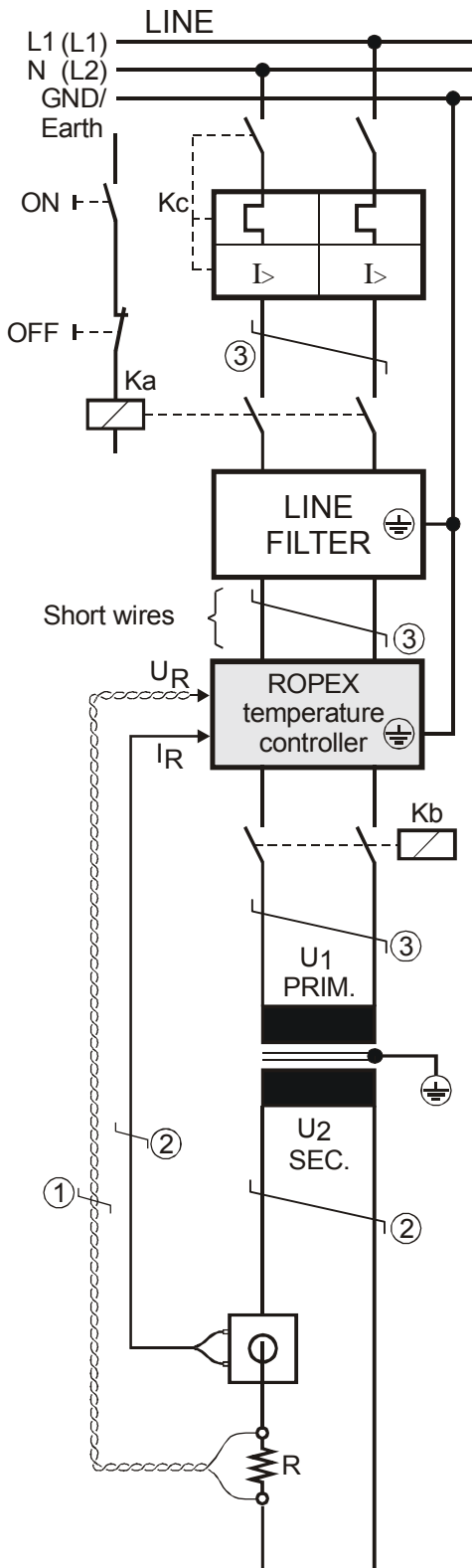

Line

400 VAC
50/60 Hz

Over-current protection

Double-pole circuit-breaker or fuses,
(☞ ROPEX Application Report)

⚠ Short-circuit protection only.

⚠ RESISTRON temperature controller not protected.

Relay Ka

For "HEAT ON - OFF" function (all-pole) or "EMERGENCY STOP".

Line filter

The filter type and size must be determined according to the load, the transformer and the machine wiring (☞ ROPEX Application Report).

⚠ Do not run the filter supply wires (line side) parallel to the filter output wires (load side).

CIRUS temperature controller

Relay Kb

Load break (all-pole), e.g. in combination with the alarm output of the temp. controller (ROPEX recommendation).

⚠ When using a series resistor RV-....-1 the relay Kb shall be installed.

Impulse Transformer

Designed according to VDE 0570/EN 61558 (isolating transformer with reinforced insulation). Connect core to ground.

⚠ Use transformers with a one section bobbin. The power, duty cycle and voltage values must be determined individually according to the application (☞ ROPEX Application Report and "Accessories" leaflet for impulse transformers).

Wiring

The wire cross-sections depend on the application (☞ ROPEX Application Report).

Guide values:

Primary circuit: min. 1.5 mm², max. 2.5 mm²

Secondary circuit: min. 4.0 mm², max. 25 mm²

① Wires must always be twisted (min. 20 turns/meter).

② These wires must be twisted (min. 20 turns/meter) if several control loops are laid together ("crosstalk").

③ Twisting (min. 20 turns/meter) is recommended to improve EMC.

4.4 Line filter

To comply with EMC directives – corresponding to EN 50081-1 and EN 50082-2 – CIRUS control loops must be operated with line filters.

These filters damp the reaction of the phase-angle control on the line and protect the controller against line disturbances.

⚠ The use of a suitable line filter is part of the standards conformity and a prerequisite of the CE mark.

ROPEX line filters are specially optimized for use in CIRUS control loops. Providing that they are installed and wired correctly, they guarantee compliance with the EMC limit values.

You can find the exact specification of the line filter in the ROPEX Application Report calculated for your particular heatsealing application.

For more technical information: ↪ "Line filter" documentation.

It is permissible to supply several CIRUS control loops with a single line filter, providing the total current does not exceed the maximum current of the filter.

The wiring instructions contained in section 4.3 "Power supply" on page 8 must be observed.

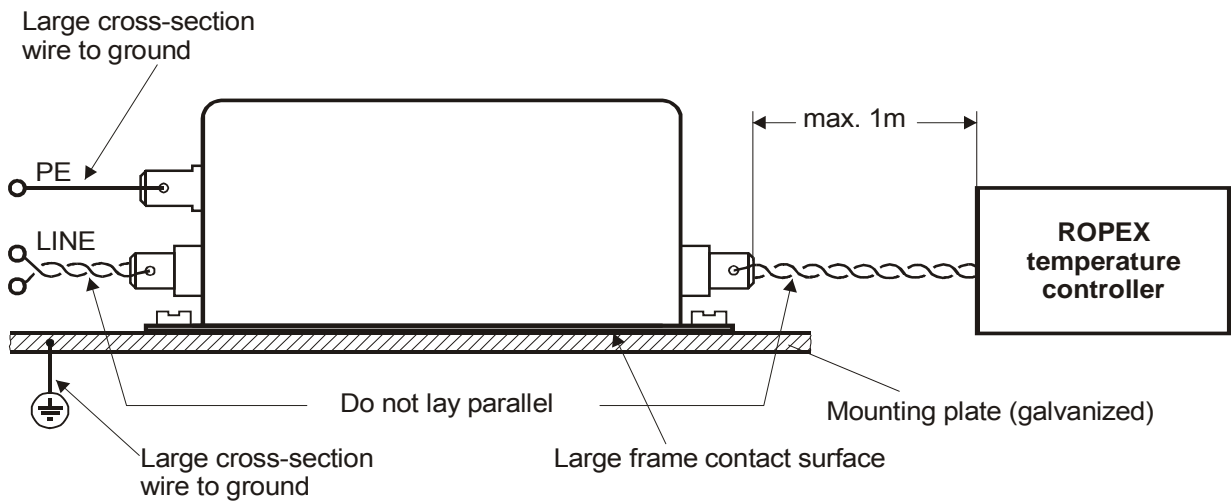

4.5 Current transformer PEX-W3/-W4

The PEX-W3/-W4 current transformer supplied with the RESISTRON temperature controller is an integral part

of the control system. The current transformer may only be operated if it is connected to the temperature controller correctly (↪ section 4.3 "Power supply" on page 8).

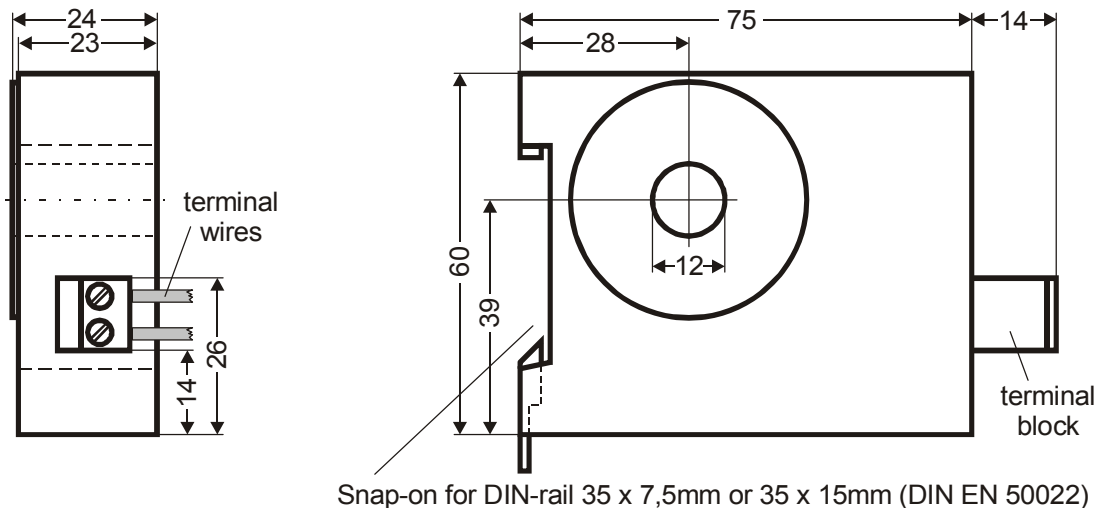

4.6 Wiring diagram (standard)

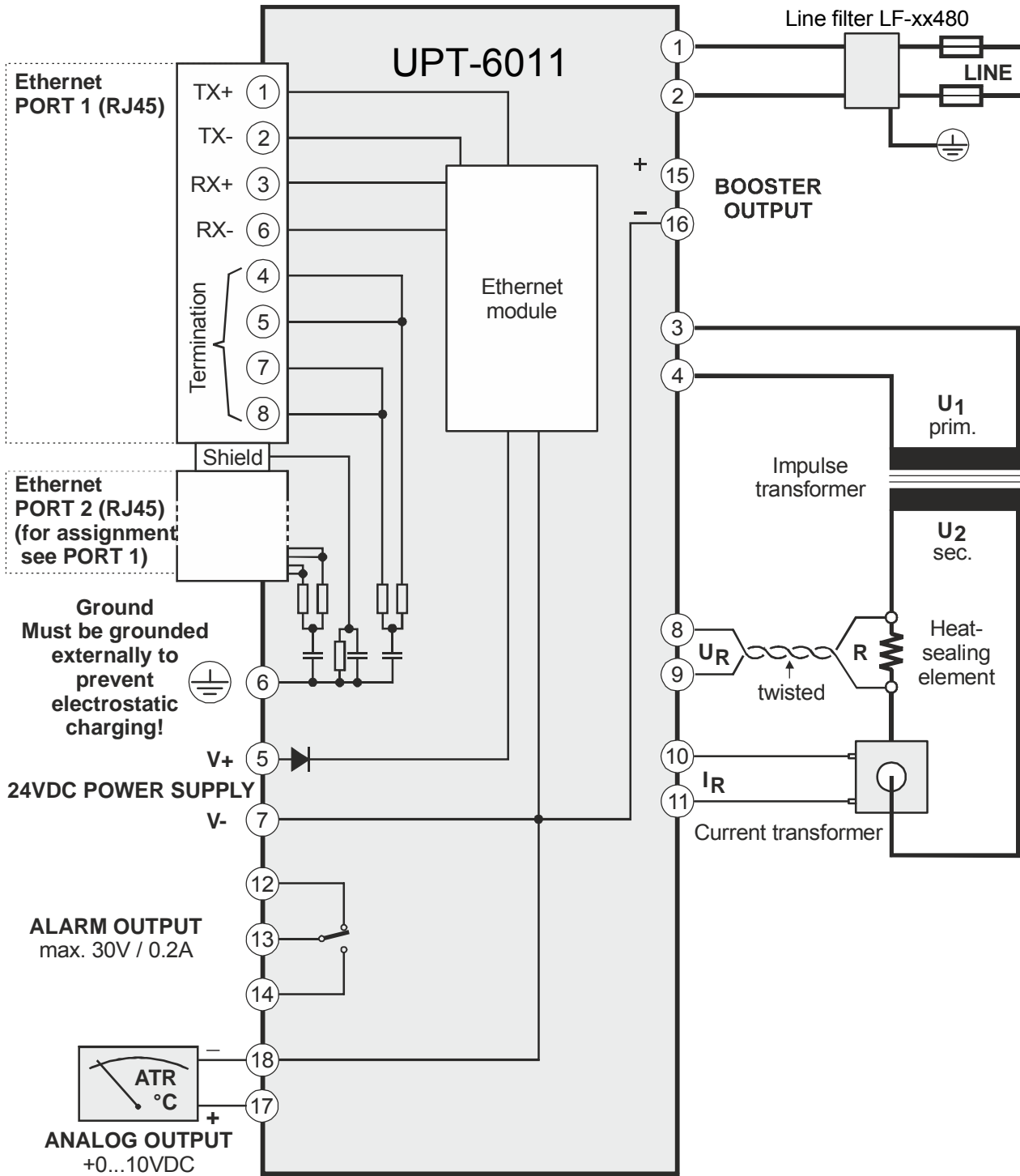

4.7 Wiring diagram with booster connection

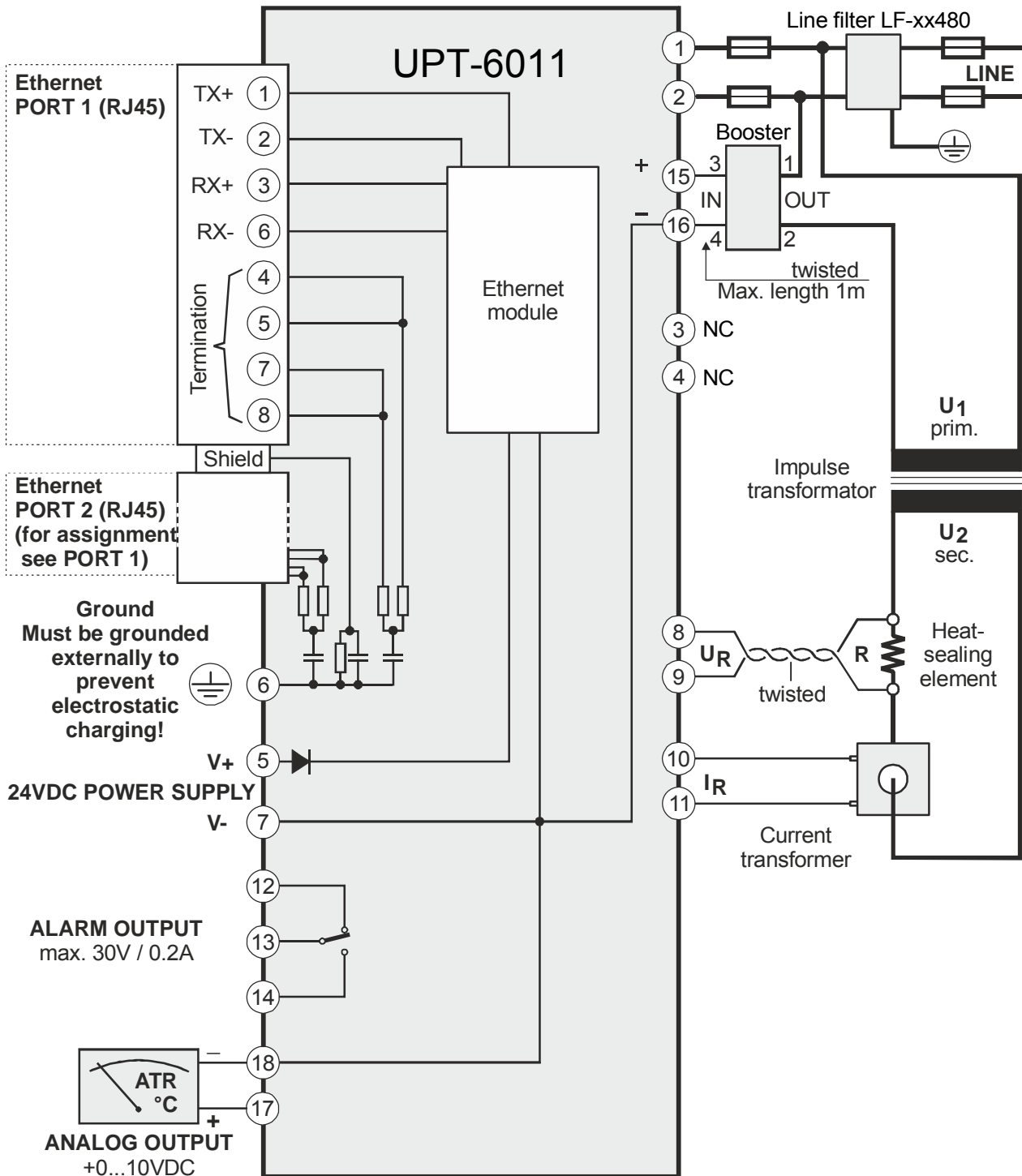

5 Startup and operation

5.1 View of the device

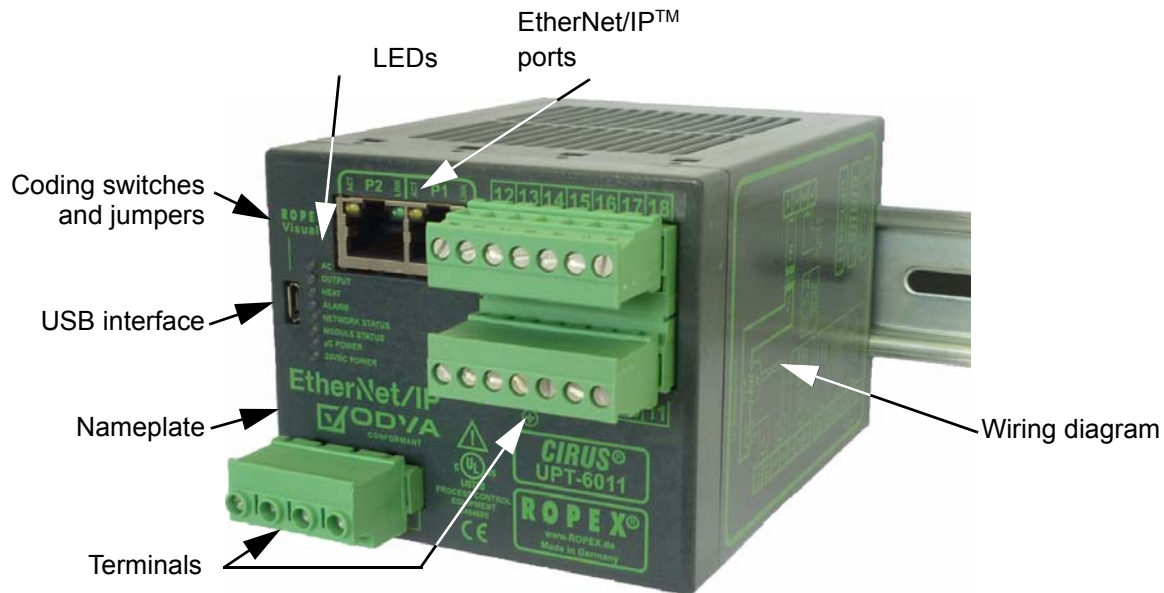

5.2 Device configuration

⚠ The controller must be switched off in order to configure the coding switches and slide switches.

5.2.1 Configuration of the secondary voltage and current ranges

The secondary voltage and current ranges are automatically configured during the automatic calibration

function (AUTOCAL). The voltage is configured in the range from 0.4 VAC to 120 VAC and the current in the range from 30 A to 500 A. If the voltage and / or current are outside of the permissible range, a detailed error message appears on the controller (↪ section 6.19 "Error messages" on page 46).

If the secondary current I_2 is less than 30 A, the secondary high-current wire must be laid twice (or several times) through the PEX-W2, PEX-W3, or PEX-W4 current transformer (↪ ROPEX Application Report).



5.2.2 Configuration of the rotary coding switch for the temperature range and alloy

Switch position	Temp. range	Temp. coefficient	Band alloy
0	300°C	1700ppm/K	(CIRUS)
4	500°C	1700ppm/K	(CIRUS)
9	PC-CONFIGURATION		

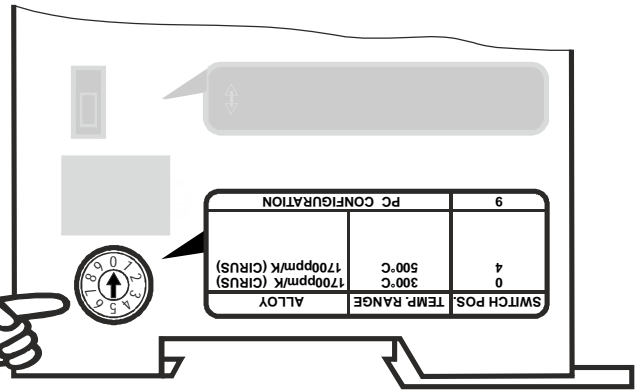
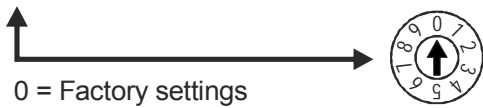

⚠ The setting of the rotary coding switch for the temperature range and alloy can be overwritten with the parameter data (↪ section 6.7 "Parameter object (class: 0x0F)" on page 23).

time the controller is switched on. The preset IP address of the UPT-6011 is configured as follows, depending on the settings of the rotary coding switches:

If the switch is set to "9", more temperature ranges and alloys can be selected in the ROPEX visualization software (↪ section 6.12 "USB interface for visualization software (ROPEXvisual®)" on page 44).

Rotary coding switch	IP address
00	Last IP address assigned is static
01...FD	192.168.001.1...253
FE	Configuration determined by PC visualization software
FF	Last configuration assigned is erased

5.2.3 Configuration of the rotary coding switch for the IP address

These coding switches allow you to set the least significant byte in the IP address of the UPT-6011 in the EtherNet/IP™ network to a value between 0x01 and 0xFD. A new setting does not take effect until the next

IP address selectable.

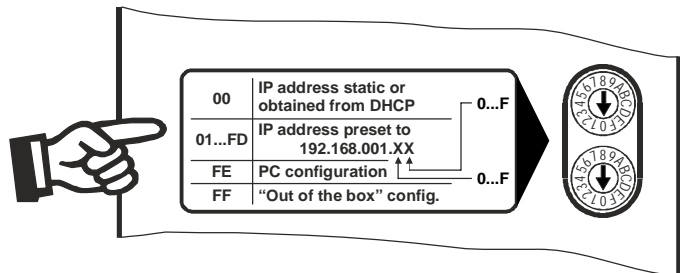
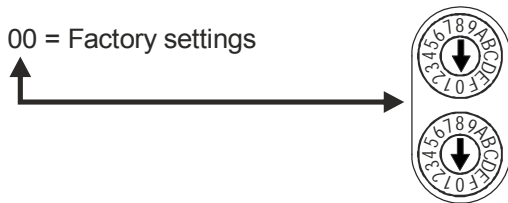

The "01...FE" switch positions allow an IP address to be assigned, or the DHCP client switched on and off, via the EtherNet/IP™ interface either using a software tool (e.g. Rockwell's "BOOT / P-DHCP Server") or by manually accessing the TCP / IP object. These settings

are stored in the controller. However, when the power supply to the controller is momentarily interrupted, the stored values are only used if the rotary coding switches are set to "00". All other switch positions cause the stored values to be temporarily overwritten.

5.2.4 Configuration of the alarm relay

Alarm relay contact opened by alarm/PC-CONFIGURATION.

Alarm relay contact closed by alarm. (factory setting)

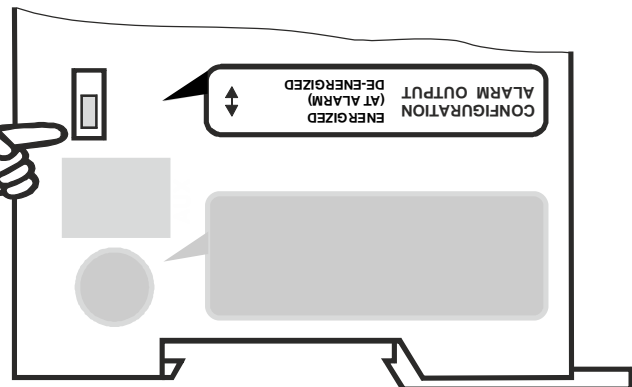

If the switch is set to "Alarm relay de-energized at alarm / PC CONFIGURATION", you can select more alarm output configurations in the ROPEX visualization

software (↪ section 6.12 "USB interface for visualization software (ROPEXvisual®)" on page 44).

5.3 Heating element

5.3.1 General

The heating element is a key component in the control loop because it is not only a heating element but also a sensor. The geometry of the heating element is too complex to be discussed at length here. We shall therefore only refer to a few of the most important physical and electrical properties.

The measuring principle used for this system requires a heating element alloy with a suitable temperature coefficient TCR, i.e. one whose resistance increases as the temperature rises.

Too low a TCR leads to oscillation or uncontrolled heating.

If a heating element with a higher TCR is used, the controller must be calibrated for it.

! The base resistance of the heating element increases continuously during operation (owing to the design). The "AUTOCAL" function must therefore be run again approximately every 100,000 heatsealing cycles in order to prevent ACTUAL temperature measuring errors.

5.3.2 Replacing the heating element

The supply voltage (all poles) must be disconnected from the CIRUS temperature controller in order to replace the heating element.

! The heating element must be replaced in accordance with the instructions provided by the manufacturer.

Each time the heating element is replaced, you must run the "AUTOCAL" function (↪ section 6.5.1 "Automatic zero calibration "AUTOCAL" (AC)" on page 19) and set the correction factor Co (↪ section 6.7.8 "Correction factor Co" on page 38). Any production-related resistance tolerances of the heating element are compensated in this way.

5.4 Startup procedure

Please also refer to section 1 "General information" on page 3 and section 2 "Application" on page 4.

! Mounting, installation and startup may only be performed by authorized persons who have received suitable instruction and are familiar with the associated risks and warranty provisions.

Condition: The device must be correctly installed and connected (↪ section 4 "Mounting and installation" on page 7).

All possible settings are described in detail in section 6 "Device functions" on page 16 and section 5.2 "Device configuration" on page 12.

The essential controller configurations are described below:

1. Switch off the line voltage and the 24VDC auxiliary power supply, and verify that the circuit is de-ener-

gized.

2. The supply voltage indicated on the nameplate of the controller must be identical to the line voltage that is present in the system or machine. The line frequency is automatically detected by the temperature controller in the range from 47 to 63 Hz.
3. Either set the desired device IP address with the rotary coding switches or assign it using a DHCP server (↪ section 5.2 "Device configuration" on page 12).
4. Link the device description file (EDS) into the EtherNet/IP™ scanner (↪ section 6.3), then select the required parameters, make the connections, assign an IP address, and start the communication.
5. Make sure the "ST" bit is not set.
6. Switch on the line voltage and the 24 VDC auxiliary supply (the order is arbitrary).
7. When the voltage is switched on, the yellow "AUTOCAL" LED lights up for approximately 0.3 seconds to indicate that the controller is being powered up correctly.

⚠ If the red "ALARM" LED lights up for 0.3 s when the voltage is switched on in addition to the yellow "AUTOCAL" LED, the configuration of this controller has been changed in the visualization software (↪ section 6.12 "USB interface for visualization software (ROPEXvisual®)" on page 44). In order to avoid malfunctions, please check the controller configuration before continuing the startup procedure.

8. One of the following states then appears:

"ALARM" LED	"OUTPUT" LED	ACTION
OFF	Short impulses every 1.2 s	Go to step 9
BLINKS fast (4 Hz)	OFF	Go to step 9
LIT continuously	OFF	<u>Error code 901</u> (error group: 7): No line voltage / sync signal (↪ section 6.2) <u>Otherwise:</u> Error diagnosis (↪ section 6.19)

9. Activate the "AUTOCAL" function while the heating element is still cold by setting the "AC" bit (AUTOCAL) in the EtherNet/IP™ protocol (↪ section 6.4 "Communication protocol" on page 19). The yellow "AUTOCAL" LED lights up for the duration of the calibration process (approx. 10...15 s). The "AA" bit (AUTOCAL active) is additionally set and a voltage of 0 VDC appears at the actual value output (terminals 17+18). If an ATR-x is connected, it indicates 0...3°C.

After the zero point has been calibrated, the "AUTOCAL" LED goes out and the "AA" bit is reset. A voltage of 0.66 VDC (300°C range and AUTOCAL temperature = 20°C) or 0.4 VDC (500°C range) appears at the actual value output. If an ATR-x is connected, it must be set to "Z".

If the zero point was not calibrated successfully, the "AL" bit (alarm active) is set and the red "ALARM" LED blinks slowly (1 Hz). In this case the controller configuration is incorrect (↪ section 5.2 "Device configuration" on page 12, ROPEX Application Report). Repeat the calibration after correcting the controller configuration.

10. After the zero point has been successfully calibrated, specify a defined temperature by means of the EtherNet/IP™ protocol (set point) and set the "ST" bit. The "RA" bit (control active) is then activated and the "HEAT" LED lights up. The heating and control process can be observed at the actual value output.

The controller is functioning correctly if the temperature (which corresponds to the signal change at the analog output or the actual value in the EtherNet/IP™ protocol) is a regular curve, in other words it must not jump abruptly, fluctuate, or temporarily deviate in the wrong direction. This kind of behavior would indicate that the U_R measurement cable was laid incorrectly.

If an error code is displayed, proceed as described in section 6.19 "Error messages" on page 46.

11. Optimize the heating and control process either by adjusting the correction factor C_o in the parameter data (EDS file) or using the parameter object (↪ section 6.7.8 "Correction factor C_o " on page 38). Any production-related resistance tolerances of the heating element are compensated in this way.

6 Device functions

See also section 4.6 "Wiring diagram (standard)" on page 10.

6.1 LEDs and controls

RX/TX (yellow LED)	Lit or blinking if Ethernet frames are transmitted.
LINK (green LED)	Lit if connection exists to Ethernet.
AUTOCAL (yellow LED)	Lit while AUTOCAL process is executing.
OUTPUT (Green LED)	Indicates pulses in measurement mode. In control mode, luminous intensity is proportional to heating current.
HEAT (yellow LED)	Lit during heating phase.
ALARM (Red LED)	Lit or blinking to indicate fault.
NETWORK STATUS (red/green)	Lit (green) if connection exists to EtherNet/IP scanner; lit (red) to indicate network error.
MODULE STATUS (Red/green)	Lit (green) if there are no communication errors.
µC POWER (green LED)	Lit if internal power supply for EtherNet/IP interface is OK.
24V POWER (Green LED)	Lit if external 24VDC power supply is present.

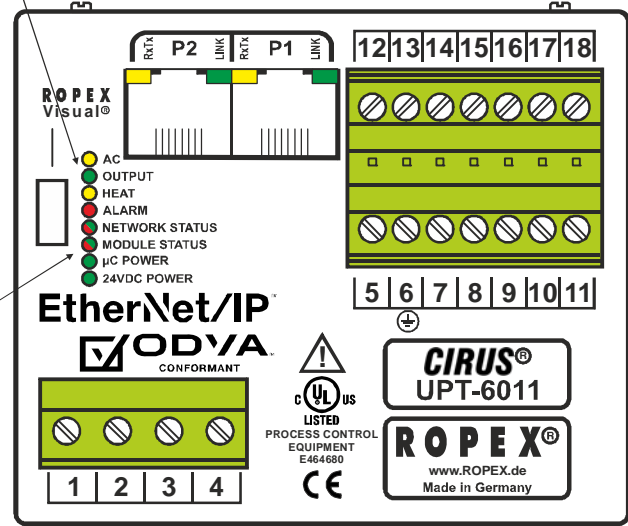

In addition to the functions shown above, the LEDs also indicate various controller operating states. These states are described in detail in the table below:

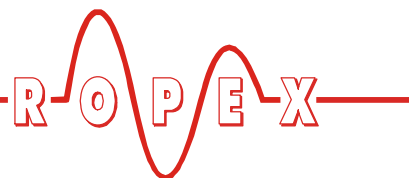

LED	Blinks slowly (1 Hz)	Blinks fast (4 Hz)	Lit continuously
AUTOCAL (yellow)	"RS" bit set (reset)	AUTOCAL requested but function blocked (e.g. START active)	AUTOCAL executing
	LED blinks at a different frequency: Supply voltages incorrect (too low)		
HEAT (yellow)	—	START requested but function blocked (e.g. AUTOCAL active, set temperature < 40°C)	START executing
OUTPUT (green)	In control mode, luminous intensity is proportional to heating current.		
ALARM (red)	Configuration error, no AUTOCAL possible	Controller calibrated incorrectly, run AUTOCAL	Error, ↪ section 6.19
MODULE STATUS	Green: Standby Red: Warning, e.g. rotary coding switch setting changed	Red / green: Self-test	Green: Normal operation Red: Serious communication error
NETWORK STATUS	Green: No connection but IP address received Red: Connection timeout	Red / green: Self-test	Green: At least one connection to scanner Red: IP address of controller already assigned
LINK PORT 1, 2 (green)	—	—	Connection exists to Ethernet
RX / TX PORT 1, 2 (yellow)	Device is transmitting / receiving Ethernet frames		

6.2 EtherNet/IP™ communication

The following sections only describe controller-specific functions. For general information on the EtherNet/IP™ interface and the system configuration, please refer to the description of your PLC.

The controller can communicate via the EtherNet/IP™ interface provided the 24 VDC supply voltage (terminals 19+20) is present.

If no line voltage is present however (e.g. if it is switched off in order to open a door), error code 901 or 201 (error group 7, no line voltage / sync signal) appears on the controller and the alarm relay is switched. This happens due to the absence of line voltage. The error message can be reset by switching on the line voltage again and setting the "RS" bit (↪ section 6.5.3 "Reset (RS)" on page 20).

You can easily process the error code that appears if the line voltage is switched off – or suppress switching of the alarm relay – in the PLC program.

6.3 Device description file (EDS)

The configuring tools for the EtherNet/IP™ scanner interpret the content of the device description file (EDS) and use this information to create a parameter set for the EtherNet/IP™ scanner which controls user data traffic. The ROPEX_UPT-6011_V2_1.eds file of the UPT-6011 contains all essential controller information for the configuration, e.g. the I/O data description, parameter descriptions etc. The device description files and the associated image files (.BMP and .ICO) can be requested by e-mail (support@ropex.de) or downloaded from our website (www.ropex.de).

If the controller already has an IP address, the device description file can also be downloaded from the integrated web server. Alternatively, you can download it from the controller via the file object using CIP services. After linking the required device description file into the configuring tool, you must assign an IP address to the controller. DHCP is activated by default to enable the controller to request an IP address from a DHCP server in the network. You must also select the desired parameter values.

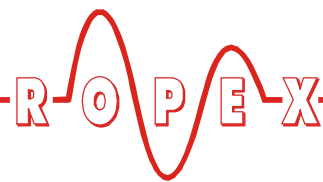

6.4 Communication protocol

The communication protocol consists of 2x16 bit input words and 3x16 bit output words (from the point of view of the controller). This protocol separates the set point and the actual value of the UPT-6011 from the status

information and the control functions, to simplify decoding by the EtherNet/IP™ scanner.

Bits 0...7 form the low byte and bits 8...15 the high byte ("INTEL format").

The 2 x 16-bit **input data** contains the set point in word ① and the control functions in word ②:

①	Spare							Set point / AC temperature									
Name:	0	0	0	0	0	0	0										
Bit no.:	15	14	13	12	11	10	9	8	7	6	5	4	3	2	1	0	

②	Spare					Channel			Spare			Control function				
Name:	0	0	0	0	0	CH2	CH1	CH0	0	0	0	MA	MP	RS	ST	AC
Bit no.:	15	14	13	12	11	10	9	8	7	6	5	4	3	2	1	0

The 3 x 16-bit **output data** contains the actual value in word ①, the status information in word ②, and the error code in word ③:

①	Actual value (signed)															
Name:																
Bit no.:	15	14	13	12	11	10	9	8	7	6	5	4	3	2	1	0

②	Spare				Channel			Status information								
Name:	0	0	0	0	CH2	CH1	CH0	SA	IA	WA	AA	AG	AL	TE	TO	RA
Bit no.:	15	14	13	12	11	10	9	8	7	6	5	4	3	2	1	0

③	Error code															
Name:	0	0	0	0	0	0	A9	A8	A7	A6	A5	A4	A3	A2	A1	A0
Bit no.:	15	14	13	12	11	10	9	8	7	6	5	4	3	2	1	0

6.5 Input data

The term "input data" refers to the data that is transferred from the EtherNet/IP™ scanner to the UPT-6011. It contains the set point as well as the control functions such as START or AUTOCAL for the UPT-6011. These functions are explained in the following.

6.5.1 Automatic zero calibration "AUTOCAL" (AC)

Owing to the automatic zero calibration (AUTOCAL) function, there is no need to adjust the zero point manually on the controller. This function adjusts the con-

troller to the current and voltage signals present in the system and calibrates it to the value which is predefined in the parameter data (↪ section 6.7.4 "Variable calibration temperature" on page 38). If no parameter data is transferred by the EtherNet/IP™ scanner, the default value is 20°C.

Some EtherNet/IP™ scanners do not allow the parameter data to be changed during operation. In this case, the calibration temperature cannot be adapted to the actual ambient conditions in the machines.

The calibration temperature can thus be specified by means of the "Set point / AC temperature" input data whenever the zero point is calibrated, provided this is permitted in the parameter data (↪ section 6.7.4 "Vari-

able calibration temperature" on page 38). You can specify it in the 0...+40°C range. The specified calibration temperature must be entered in the "Set point / AC temperature" input data when the "AUTOCAL" function is activated ("AC" bit = 1). This specified value must not be changed until the "AUTOCAL" function has finished. If the specified temperature is too high (greater than 40°C) or if the specified value fluctuates, an error message appears (error codes 115 and 116; ↪ section 6.19 "Error messages" on page 46).

The AUTOCAL request ("AC" bit = 1) is executed by the controller provided the "AUTOCAL" function is not blocked.

The automatic calibration takes around 10...15 seconds. The heating element is not heated during this period. The yellow LED on the front panel lights up while the "AUTOCAL" function is executing and the controller shows "AUTOCAL active" ("AA" bit = 1) in the output data. The actual value output (terminals 17+18) changes to 0...3°C (corresponds to approx. 0 VDC).

If the temperature of the heating element fluctuates, the "AUTOCAL" function is executed a maximum of three times. If the function still cannot be executed successfully, an error message appears (↪ section 6.19 "Error messages" on page 46).



You should always wait for the heating element to cool down (to ambient temperature) before activating the "AUTOCAL" function.

Reasons for blocked "AUTOCAL" function:

1. An AUTOCAL request cannot be accepted until 10 seconds after the controller is switched on. During this time the controller shows "AUTOCAL blocked" ("AG" bit = 1) in the output data.
2. The "AUTOCAL" function is not activated if the heating element cools down at a rate of more than 0.1 K/s. If the "AC" bit is set, the function is automatically executed when the cooling rate falls below the specified value.
3. If the "START" bit is set ("ST" bit = 1), the "AUTOCAL" function is not executed ("HEAT" LED lit).
4. If the "RESET" bit is set ("RS" bit = 1), the "AUTOCAL" function is not executed.
5. The "AUTOCAL" function cannot be activated if error codes 101...103, 201...203, 801 or 9xx appear as soon as the controller is switched on (↪ section 6.19 "Error messages" on page 46). It also cannot be activated if error codes 201...203, 801, or 9xx appear and the controller has operated

correctly at least once since being switched on.

If the "AUTOCAL" function is blocked ("AG" bit = 1), an AUTOCAL request ("AC" bit = 1) causes the "AUTOCAL" LED to blink fast (4 Hz).

6.5.2 Start (ST)

When the "START" bit is set ("ST" bit = 1), the controller's internal set / actual comparison is enabled and the heating element is heated to the SET temperature. It remains at this temperature either until the "ST" bit is reset or until the actual heating time exceeds the preset heating time limit (↪ section 6.7.5 "Heating time limit" on page 38).

The "HEAT" LED on the front panel of the UPT-6011 lights up continuously for the duration of the heating time.

A start request is not processed as long as the "AUTOCAL" function is active, a fault is present on the controller, the set point is less than 20°C higher than the calibration temperature, or the "RS" bit is set. In this case, the "HEAT" LED blinks.

The heatup process is terminated if the "ST" bit is reset or an EtherNet/IP™ error occurs.

The "ST" bit is only accepted if the "AUTOCAL" function is deactivated and there are no faults.

The alarm relay is switched if the "ST" bit is set while a warning with error code 8...12 (104...106, 111...114, 211, 302, or 303) is indicated (↪ section 6.19 "Error messages" on page 46). The heating element is not heated.

6.5.3 Reset (RS)

This bit resets the controller if the controller shows a fault.

No AUTOCAL or START requests are accepted as long as the "RS" bit is set. Until it is reset again, only error codes 5 and 7 (201...203, 901, 913) are evaluated and output by the error diagnosis function. The power unit is not activated in this state and no measuring impulses are generated. As a result of this, the actual value is no longer updated. The reset request is not accepted until the "RS" bit is reset. EtherNet/IP™ Communications are not interrupted by a controller reset.

The controller actual value output changes to 0...3°C (i.e. approximately 0 VDC) and the "SA" status bit is set in order to set the "RS" bit.

The "AUTOCAL" function is not canceled if the "RS" bit is set while it is executing.

The controller performs an internal initialization lasting approximately 500 ms after the "RS" bit is reset. The

next heatsealing process cannot be started until it has finished.

If a Kb contactor is used to deactivate the control loop (↪ section 4.3 "Power supply" on page 8), it must be reliably energized again 200 ms at the latest after the "RS" bit is reset (note the contactor switching and delay times). If it is energized too late, an error message appears on the controller.

6.5.4 Measurement pause (MP)

No more measuring impulses are generated by the controller as soon as the "MP" bit is set. Until it is reset again, only error codes 5 and 7 (201...203, 901, 913) are evaluated and output by the error diagnosis function. In addition, the actual value is no longer updated. The last valid value before the bit was set is output. As soon as the bit is reset, new measuring impulses are generated, all error messages are evaluated, and the actual value is updated again.

This bit is only active in measurement mode. "ST", "RS", and "AC" take priority.

The bit is suitable for all applications where the electrical connections of the heating element must be disconnected during normal operation without triggering a fault (e.g. sliding rail contacts).

Unlike the "RS" bit (RESET), the "MP" bit does not reset any faults when it is set. The controller is active again as soon as the bit is reset, in other words there is no initialization phase.

When the controller is switched on, it does not evaluate the "MP" bit until the system test (including the functional test of the heating circuit) has been successfully completed. This can take several hundred milliseconds.

6.5.5 Master AUTOCAL (MA)

Setting this control bit starts a calibration as described in section 6.5.1 "Automatic zero calibration "AUTOCAL" (AC)" on page 19. However, if the "AUTOCAL" function is successful, the heating element resistance which is determined by the controller is also used as a reference value, e.g. after replacing the heating element.

This reference value serves to calculate the deviation from the calibration value for all subsequent calibrations (initiated with the "AC" bit). This deviation helps you assess aging of the heating element.

The deviation from the calibration value is queried by means of the parameter object.

6.5.6 Channel selection (CH0...CH2)

The temperature controller has separate memories for up to eight calibration data records. A calibration data record contains the values determined by the temperature controller during the "AUTOCAL" function. By storing the calibration data records, you can alternate between different sealing tools without having to run the "AUTOCAL" function every time the tool is changed. You only need to execute AUTOCAL if you connect a new heating element.

Since different calibration values, AUTOCAL temperatures, correction factors, and temperature coefficients are stored in the controller for this purpose, the required calibration data record 0...7 can be selected with the three bits CH0...CH2. You can switch to another channel at any time.

This function is useful, for instance, in applications where frequent changes of format are necessary. The tools can then be changed as required in order to handle the different formats. A channel containing the relevant calibration data record is assigned to each tool. Once all tools have been calibrated with a unique channel assignment, they can be changed at any time simply by selecting the appropriate channel.

If the application does not require any format changes, the channel can remain set to 0. In this case, the temperature controller behaves in exactly the same way as older models where different calibration data records are not supported.

It is possible to switch to another channel during the "AUTOCAL" function; however, the controller continues working with the original channel until the "AUTOCAL" function has finished. The channel currently being used by the controller is shown in the status information.

6.5.7 Set point

A set point of up to 300°C or 500°C is allowed, depending on the selected temperature range (↪ section 6.7.1 "Temperature range and alloy" on page 38). If you attempt to enter a higher set point, it is limited internally to 300°C or 500°C.

6.6 Output data

The term "output data" refers to the data that is transferred from the UPT-6011 to the EtherNet/IP™ scanner. It contains the current actual value as well as all important information on the current status of the controller. If a fault is signaled, it can be diagnosed accurately with the help of the error code.

6.6.1 AUTOCAL active (AA)

The "AA" bit indicates that the "AUTOCAL" function is executing.

6.6.2 AUTOCAL blocked (AG)

If the "AG" bit is set, the "AUTOCAL" function is temporarily blocked. This is the case if "START" is active or the heating element is still in the cooling phase.

6.6.3 Alarm active (AL)

If the "AL" bit is set, an alarm has been triggered but not yet reset. The error code provides information on the exact cause (↪ section 6.19 "Error messages" on page 46).

6.6.4 Warning active (WA)

This bit can be set in addition to the "AL" bit. If the "WA" bit is set, a warning is output to indicate the current fault. In this case, the alarm relay is not active.

6.6.5 Temperature achieved (TE)

The "TE" bit is set if the actual temperature exceeds 95% of the set temperature. This status bit is reset again as soon as you exit control mode ("ST" bit = 0) or a fault is signaled ("AL" bit = 1).

6.6.6 Temperature OK (TO)

The UPT-6011 checks whether the actual temperature is within a settable tolerance band ("OK" window) either side of the set temperature. The high ($\Delta\vartheta_{high}$) and low ($\Delta\vartheta_{low}$) limits of the tolerance band can be changed independently of one another in the parameter data (↪ section 6.7 "Parameter object (class: 0x0F)" on page 23). The following settings are possible:

1. "Off"
The "TO" bit is always reset.
2. "Active when Tact = Tset" (factory setting)
The "TO" bit is set if the actual value is inside the specified temperature tolerance band. If the actual temperature is outside of the tolerance band, the "TO" bit is reset (see graph below).

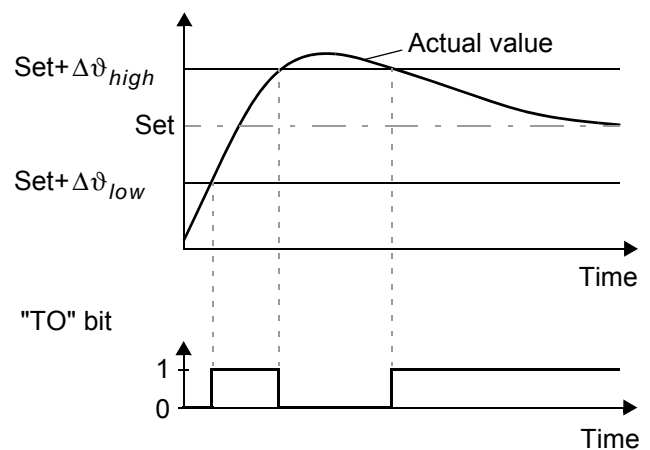

Unlike the "Temperature achieved" status bit ("TE" bit), the actual temperature is evaluated independently of the control mode.

3. "Active when Tact = Tset" with latch function

A heatsealing cycle starts when the "ST" bit is set. The "TO" bit is set when the actual temperature reaches the temperature tolerance band for the first time during a heatsealing cycle. If the actual temperature leaves the tolerance band again while the "ST" bit is still set, the "TO" bit is reset (Fig. a.). If the actual temperature does not leave the tolerance band while the "ST" bit is still set, the "TO" bit is not reset until the start of the next heatsealing cycle (latch function, Fig. b.). The switching state of the "TO" bit can thus be queried after the "ST" bit has been reset and before the start of the next heatsealing cycle.

a.) Temperature *not* OK

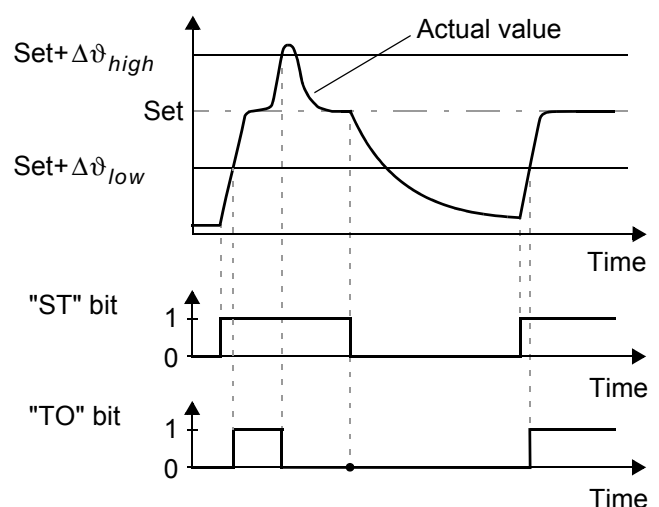

b.) Temperature OK

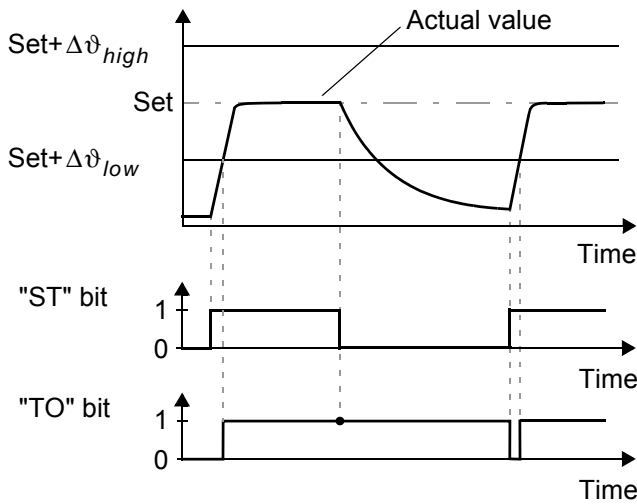

The limits of the tolerance band are adjustable up to a maximum of ±99 K.

6.6.7 Control active (RA)

The UPT-6011 has successfully accepted the "START" request and entered control mode if the "RA" bit = 1.

6.6.8 Info active (IA)

This bit is reserved for future use and is not currently supported (it is always set to 0).

6.6.9 Standby active (SA)

This bit is active if the "RS" bit is set. It shows the PLC when the controller has accepted the "RS" or "MP" bit, so that these bits can be reset again (handshake).

6.6.10 Actual value

6.6.11 All 16 bits of the first word must be interpreted as a signed number (twos complement notation). The resolution is 1°C. During the calibration procedure or if a fault occurs, the actual value is 0. **Error codes**

If a fault is signaled ("AL" bit = 1), you can determine the exact cause with the help of the error code. The error code is contained in the third word at bit positions 0...9 (↪ section 6.19 "Error messages" on page 46).

6.7 Parameter object (class: 0x0F)

In accordance with the CIP specification, the UPT-6011 provides a parameter object containing all of the device parameters.

All instances of the parameter object support the "Get_Attribute_Single" and "Get_Attribute_All" services. The class (instance 0) additionally supports the "Save", "Restore", and "Reset" services. The instances additionally support the "Set_Attribute_Single" service for attribute 1. The parameter object has the following structure:

Instance	Attribute ID	Data type ¹	Name	Default value	Value range
0 (class)	1	UINT	Revision	1	
	2	UINT	Max. instance	17	
	6	UINT	Max. class attribute	9	
	7	UINT	Max. instance attribute	6	
	8	UINT	Parameter class description	13	
	9	UINT	Configuration assembly	102	

Instance	Attribute ID	Data type ¹	Name	Default value	Value range
1	1	USINT	Temperature range / alloy	10	0, 4, 9, 10, 11 (↪ 6.7.1)
	2	USINT	Link path length	6	
	3	EPATH	Link path	20 0F 24 01 30 01	
	4	WORD	Descriptor	0x0000	
	5	USINT	Data type	0xC6	
	6	USINT	Data length	1	
2	1	USINT	Low temperature OK threshold	10 K	3...99 K
	2	USINT	Link path length	6	
	3	EPATH	Link path	20 0F 24 02 30 01	
	4	WORD	Descriptor	0x0000	
	5	USINT	Data type	0xC6	
	6	USINT	Data length	1	
3	1	USINT	High temperature OK threshold	10 K	3...99 K
	2	USINT	Link path length	6	
	3	EPATH	Link path	20 0F 24 03 30 01	
	4	WORD	Descriptor	0x0000	
	5	USINT	Data type	0xC6	
	6	USINT	Data length	1	
4	1	SINT	Calibration temperature	20°C	-1 (= variable), 0...40°C
	2	USINT	Link path length	6	
	3	EPATH	Link path	20 0F 24 04 30 01	
	4	WORD	Descriptor	0x0000	
	5	USINT	Data type	0xC2	
	6	USINT	Data length	1	

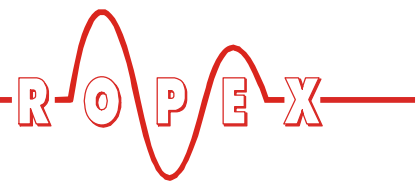

Instance	Attribute ID	Data type ¹	Name	Default value	Value range
5	1	USINT	Heating time limit (10 ms steps)	500 (5.00 s)	0...999 (0...9.99 s)
	2	USINT	Link path length	6	
	3	EPATH	Link path	20 0F 24 05 30 01	
	4	WORD	Descriptor	0x0004 (scaling supported)	
	5	USINT	Data type	0xC7	
	6	USINT	Data length	2	
	13	USINT	Factor	1	
	14	USINT	Divisor	100	
	15	USINT	Base	1	
	16	USINT	Offset	0	
6	1	USINT	Measuring impulse duration	1.7 ms (17)	1.7...3.0 ms (17...30)
	2	USINT	Link path length	6	
	3	EPATH	Link path	20 0F 24 06 30 01	
	4	WORD	Descriptor	0x0004 (scaling supported)	
	5	USINT	Data type	0xC6	
	6	USINT	Data length	1	
	13	USINT	Factor	1	
	14	USINT	Divisor	10	
	15	USINT	Base	1	
	16	USINT	Offset	0	
7	1	BOOL	Data format	Little Endian, Intel (0)	Little Endian, Intel (0), Big Endian, Motorola (1)
	2	USINT	Link path length	6	
	3	EPATH	Link path	20 0F 24 07 30 01	
	4	WORD	Descriptor	0x0000	
	5	USINT	Data type	0xC6	
	6	USINT	Data length	1	

Instance	Attribute ID	Data type ¹	Name	Default value	Value range
8	1	USINT	Correction factor	100	25...200%
	2	USINT	Link path length	6	
	3	EPATH	Link path	20 0F 24 08 30 01	
	4	WORD	Descriptor	0x0000	
	5	USINT	Data type	0xC7	
	6	USINT	Data length	2	
9	1	UINT	Maximum start temperature	100	20...500°C
	2	USINT	Link path length	6	
	3	EPATH	Link path	20 0F 24 09 30 01	
	4	WORD	Descriptor	0x0000	
	5	USINT	Data type	0xC7	
	6	USINT	Data length	2	
10	1	UINT	Temperature coefficient	1700 ppm/K	400...4000 ppm/K
	2	USINT	Link path length	6	
	3	EPATH	Link path	20 0F 24 0A 30 01	
	4	WORD	Descriptor	0x0000	
	5	USINT	Data type	0xC7	
	6	USINT	Data length	2	
11	1	USINT	Temperature range	1 (300 C)	0 (200°C), 1 (300°C), 2 (400°C), 3 (500°C)
	2	USINT	Link path length	6	
	3	EPATH	Link path	20 0F 24 0B 30 01	
	4	WORD	Descriptor	0x0000	
	5	USINT	Data type	0xC6	
	6	USINT	Data length	1	
12	1	USINT	Maximum temperature	300°C	200...500°C
	2	USINT	Link path length	6	
	3	EPATH	Link path	20 0F 24 0C 30 01	
	4	WORD	Descriptor	0x0000	
	5	USINT	Data type	0xC7	
	6	USINT	Data length	2	

Instance	Attribute ID	Data type ¹	Name	Default value	Value range
13	1	BOOL	Temperature diagnosis	Off (0)	Off (0), on (1)
	2	USINT	Link path length	6	
	3	EPATH	Link path	20 0F 24 0D 30 01	
	4	WORD	Descriptor	0x0000	
	5	USINT	Data type	0xC1	
	6	USINT	Data length	1	
14	1	USINT	Temperature diagnosis delay (10 ms steps)	0 s	0...999 (0...9.99 s)
	2	USINT	Link path length	6	
	3	EPATH	Link path	20 0F 24 0E 30 01	
	4	WORD	Descriptor	0x0004 (scaling supported)	
	5	USINT	Data type	0xC7	
	6	USINT	Data length	2	
	13	USINT	Factor	1	
	14	USINT	Divisor	100	
	15	USINT	Base	1	
	16	USINT	Offset	0	
15	1	UINT	Heatup timeout (10 ms steps)	0 s	0...999 (0...9.99 s)
	2	USINT	Link path length	6	
	3	EPATH	Link path	20 0F 24 0F 30 01	
	4	WORD	Descriptor	0x0004 (scaling supported)	
	5	USINT	Data type	0xC7	
	6	USINT	Data length	2	
	13	USINT	Factor	1	
	14	USINT	Divisor	100	
	15	USINT	Base	1	
	16	USINT	Offset	0	

Instance	Attribute ID	Data type ¹	Name	Default value	Value range
16	1	USINT	Temperature OK bit	Active when Tact=Tset	Off (0), active when Tact=Tset (1), active when Tact=Tset with latch (2)
	2	USINT	Link path length	6	
	3	EPATH	Link path	20 0F 24 10 30 01	
	4	WORD	Descriptor	0x0000	
	5	USINT	Data type	0xC6	
	6	USINT	Data length	1	
17	1	USINT	Hold mode	Off	Off (0), on (1), 2 s (2)
	2	USINT	Link path length	6	
	3	EPATH	Link path	20 0F 24 11 30 01	
	4	WORD	Descriptor	0x0000	
	5	USINT	Data type	0xC6	
	6	USINT	Data length	1	
18	1	SINT	Calibration temperature, channel 1	20°C	-1 (= variable), 0...40°C
	2	USINT	Link path length	6	
	3	EPATH	Link path	20 0F 24 12 30 01	
	4	WORD	Descriptor	0x0000	
	5	USINT	Data type	0xC2	
	6	USINT	Data length	1	
19	1	USINT	Correction factor, channel 1	100	25...200%
	2	USINT	Link path length	6	
	3	EPATH	Link path	20 0F 24 13 30 01	
	4	WORD	Descriptor	0x0000	
	5	USINT	Data type	0xC7	
	6	USINT	Data length	2	



Instance	Attribute ID	Data type ¹	Name	Default value	Value range
20	1	UINT	Temperature coefficient, channel 1	1700 ppm/K	400...4000 ppm/K
	2	USINT	Link path length	6	
	3	EPATH	Link path	20 0F 24 14 30 01	
	4	WORD	Descriptor	0x0000	
	5	USINT	Data type	0xC7	
	6	USINT	Data length	2	
21	1	SINT	Calibration temperature, channel 2	20°C	-1 (= variable), 0...40°C
	2	USINT	Link path length	6	
	3	EPATH	Link path	20 0F 24 15 30 01	
	4	WORD	Descriptor	0x0000	
	5	USINT	Data type	0xC2	
	6	USINT	Data length	1	
22	1	USINT	Correction factor, channel 2	100	25...200%
	2	USINT	Link path length	6	
	3	EPATH	Link path	20 0F 24 16 30 01	
	4	WORD	Descriptor	0x0000	
	5	USINT	Data type	0xC7	
	6	USINT	Data length	2	
23	1	UINT	Temperature coefficient, channel 2	1700 ppm/K	400...4000 ppm/K
	2	USINT	Link path length	6	
	3	EPATH	Link path	20 0F 24 17 30 01	
	4	WORD	Descriptor	0x0000	
	5	USINT	Data type	0xC7	
	6	USINT	Data length	2	
24	1	SINT	Calibration temperature, channel 3	20°C	-1 (= variable), 0...40°C
	2	USINT	Link path length	6	
	3	EPATH	Link path	20 0F 24 18 30 01	
	4	WORD	Descriptor	0x0000	
	5	USINT	Data type	0xC2	
	6	USINT	Data length	1	

Instance	Attribute ID	Data type ¹	Name	Default value	Value range
25	1	USINT	Correction factor, channel 3	100	25...200%
	2	USINT	Link path length	6	
	3	EPATH	Link path	20 0F 24 19 30 01	
	4	WORD	Descriptor	0x0000	
	5	USINT	Data type	0xC7	
	6	USINT	Data length	2	
26	1	UINT	Temperature coefficient, channel 3	1700 ppm/K	400...4000 ppm/K
	2	USINT	Link path length	6	
	3	EPATH	Link path	20 0F 24 1A 30 01	
	4	WORD	Descriptor	0x0000	
	5	USINT	Data type	0xC7	
	6	USINT	Data length	2	
27	1	SINT	Calibration temperature, channel 4	20°C	-1 (= variable), 0...40°C
	2	USINT	Link path length	6	
	3	EPATH	Link path	20 0F 24 1B 30 01	
	4	WORD	Descriptor	0x0000	
	5	USINT	Data type	0xC2	
	6	USINT	Data length	1	
28	1	USINT	Correction factor, channel 4	100	25...200%
	2	USINT	Link path length	6	
	3	EPATH	Link path	20 0F 24 1C 30 01	
	4	WORD	Descriptor	0x0000	
	5	USINT	Data type	0xC7	
	6	USINT	Data length	2	
29	1	UINT	Temperature coefficient, channel 4	1700 ppm/K	400...4000 ppm/K
	2	USINT	Link path length	6	
	3	EPATH	Link path	20 0F 24 1D 30 01	
	4	WORD	Descriptor	0x0000	
	5	USINT	Data type	0xC7	
	6	USINT	Data length	2	

Instance	Attribute ID	Data type ¹	Name	Default value	Value range
30	1	SINT	Calibration temperature, channel 5	20°C	-1 (= variable), 0...40°C
	2	USINT	Link path length	6	
	3	EPATH	Link path	20 0F 24 1E 30 01	
	4	WORD	Descriptor	0x0000	
	5	USINT	Data type	0xC2	
	6	USINT	Data length	1	
31	1	USINT	Correction factor, channel 5	100	25...200%
	2	USINT	Link path length	6	
	3	EPATH	Link path	20 0F 24 1F 30 01	
	4	WORD	Descriptor	0x0000	
	5	USINT	Data type	0xC7	
	6	USINT	Data length	2	
32	1	UINT	Temperature coefficient, channel 5	1700 ppm/K	400...4000 ppm/K
	2	USINT	Link path length	6	
	3	EPATH	Link path	20 0F 24 20 30 01	
	4	WORD	Descriptor	0x0000	
	5	USINT	Data type	0xC7	
	6	USINT	Data length	2	
33	1	SINT	Calibration temperature, channel 6	20°C	-1 (= variable), 0...40°C
	2	USINT	Link path length	6	
	3	EPATH	Link path	20 0F 24 21 30 01	
	4	WORD	Descriptor	0x0000	
	5	USINT	Data type	0xC2	
	6	USINT	Data length	1	
34	1	USINT	Correction factor, channel 6	100	25...200%
	2	USINT	Link path length	6	
	3	EPATH	Link path	20 0F 24 22 30 01	
	4	WORD	Descriptor	0x0000	
	5	USINT	Data type	0xC7	
	6	USINT	Data length	2	

Instance	Attribute ID	Data type ¹	Name	Default value	Value range
35	1	UINT	Temperature coefficient, channel 6	1700 ppm/K	400...4000 ppm/K
	2	USINT	Link path length	6	
	3	EPATH	Link path	20 0F 24 23 30 01	
	4	WORD	Descriptor	0x0000	
	5	USINT	Data type	0xC7	
	6	USINT	Data length	2	
36	1	SINT	Calibration temperature, channel 7	20°C	-1 (= variable), 0...40°C
	2	USINT	Link path length	6	
	3	EPATH	Link path	20 0F 24 24 30 01	
	4	WORD	Descriptor	0x0000	
	5	USINT	Data type	0xC2	
	6	USINT	Data length	1	
37	1	USINT	Correction factor, channel 7	100	25...200%
	2	USINT	Link path length	6	
	3	EPATH	Link path	20 0F 24 25 30 01	
	4	WORD	Descriptor	0x0000	
	5	USINT	Data type	0xC7	
	6	USINT	Data length	2	
38	1	UINT	Temperature coefficient, channel 7	1700 ppm/K	400...4000 ppm/K
	2	USINT	Link path length	6	
	3	EPATH	Link path	20 0F 24 26 30 01	
	4	WORD	Descriptor	0x0000	
	5	USINT	Data type	0xC7	
	6	USINT	Data length	2	
39	1	SINT	Date (days since 1972-01-01)	01.01.2000	
	2	USINT	Link path length	6	
	3	EPATH	Link path	20 0F 24 27 30 01	
	4	WORD	Descriptor	0x0000	
	5	USINT	Data type	0xCD	
	6	USINT	Data length	2	

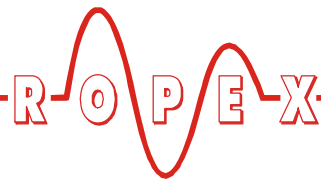

Instance	Attribute ID	Data type ¹	Name	Default value	Value range
40	1	UINT	Time (milliseconds since 00:00)	00:00:00:00	
	2	USINT	Link path length	6	
	3	EPATH	Link path	20 0F 24 28 30 01	
	4	WORD	Descriptor	0x0000	
	5	USINT	Data type	0xCE	
	6	USINT	Data length	4	
41	1	UINT	Operating hours	0	0...9999999.9 h
	2	USINT	Link path length	6	
	3	EPATH	Link path	20 0F 24 29 30 01	
	4	WORD	Descriptor	0x0014	
	5	USINT	Data type	0xC8	
	6	USINT	Data length	4	
42	1	UINT	Cycle counter (non-clearable)	0	0...99999999
	2	USINT	Link path length	6	
	3	EPATH	Link path	20 0F 24 2A 30 01	
	4	WORD	Descriptor	0x0010	
	5	USINT	Data type	0xC8	
	6	USINT	Data length	4	
43	1	UINT	Cycle counter (clearable)	0	0...99999999
	2	USINT	Link path length	6	
	3	EPATH	Link path	20 0F 24 2B 30 01	
	4	WORD	Descriptor	0x0000	
	5	USINT	Data type	0xC8	
	6	USINT	Data length	4	
44	1	UINT	Cycle counter, channel 0	0	0...99999999
	2	USINT	Link path length	6	
	3	EPATH	Link path	20 0F 24 2C 30 01	
	4	WORD	Descriptor	0x0000	
	5	USINT	Data type	0xC8	
	6	USINT	Data length	4	

Instance	Attribute ID	Data type ¹	Name	Default value	Value range
45	1	UINT	Cycle counter, channel 1	0	0...99999999
	2	USINT	Link path length	6	
	3	EPATH	Link path	20 0F 24 2D 30 01	
	4	WORD	Descriptor	0x0000	
	5	USINT	Data type	0xC8	
	6	USINT	Data length	4	
46	1	UINT	Cycle counter, channel 2	0	0...99999999
	2	USINT	Link path length	6	
	3	EPATH	Link path	20 0F 24 2E 30 01	
	4	WORD	Descriptor	0x0000	
	5	USINT	Data type	0xC8	
	6	USINT	Data length	4	
47	1	UINT	Cycle counter, channel 3	0	0...99999999
	2	USINT	Link path length	6	
	3	EPATH	Link path	20 0F 24 2F 30 01	
	4	WORD	Descriptor	0x0000	
	5	USINT	Data type	0xC8	
	6	USINT	Data length	4	
48	1	UINT	Cycle counter, channel 4	0	0...99999999
	2	USINT	Link path length	6	
	3	EPATH	Link path	20 0F 24 30 30 01	
	4	WORD	Descriptor	0x0000	
	5	USINT	Data type	0xC8	
	6	USINT	Data length	4	
49	1	UINT	Cycle counter, channel 5	0	0...99999999
	2	USINT	Link path length	6	
	3	EPATH	Link path	20 0F 24 31 30 01	
	4	WORD	Descriptor	0x0000	
	5	USINT	Data type	0xC8	
	6	USINT	Data length	4	

Instance	Attribute ID	Data type ¹	Name	Default value	Value range
50	1	UINT	Cycle counter, channel 6	0	0...99999999
	2	USINT	Link path length	6	
	3	EPATH	Link path	20 0F 24 32 30 01	
	4	WORD	Descriptor	0x0000	
	5	USINT	Data type	0xC8	
	6	USINT	Data length	4	
51	1	UINT	Cycle counter, channel 7	0	0...99999999
	2	USINT	Link path length	6	
	3	EPATH	Link path	20 0F 24 33 30 01	
	4	WORD	Descriptor	0x0000	
	5	USINT	Data type	0xC8	
	6	USINT	Data length	4	
52	1	UINT	Start temperature	-99	-99...500°C
	2	USINT	Link path length	6	
	3	EPATH	Link path	20 0F 24 34 30 01	
	4	WORD	Descriptor	0x0010	
	5	USINT	Data type	0xC3	
	6	USINT	Data length	2	
53	1	UINT	Device temperature		-60...190°C
	2	USINT	Link path length	6	
	3	EPATH	Link path	20 0F 24 35 30 01	
	4	WORD	Descriptor	0x0010	
	5	USINT	Data type	0xC3	
	6	USINT	Data length	2	
54	1	UINT	Calibration deviation, channel 0	0	-100.00...100.00%
	2	USINT	Link path length	6	
	3	EPATH	Link path	20 0F 24 36 30 01	
	4	WORD	Descriptor	0x0010	
	5	USINT	Data type	0xC3	
	6	USINT	Data length	2	

Instance	Attribute ID	Data type ¹	Name	Default value	Value range
55	1	UINT	Calibration deviation, channel 1	0	-100.00...100.00%
	2	USINT	Link path length	6	
	3	EPATH	Link path	20 0F 24 37 30 01	
	4	WORD	Descriptor	0x0010	
	5	USINT	Data type	0xC3	
	6	USINT	Data length	2	
56	1	UINT	Calibration deviation, channel 2	0	-100.00...100.00%
	2	USINT	Link path length	6	
	3	EPATH	Link path	20 0F 24 38 30 01	
	4	WORD	Descriptor	0x0010	
	5	USINT	Data type	0xC3	
	6	USINT	Data length	2	
57	1	UINT	Calibration deviation, channel 3	0	-100.00...100.00%
	2	USINT	Link path length	6	
	3	EPATH	Link path	20 0F 24 39 30 01	
	4	WORD	Descriptor	0x0010	
	5	USINT	Data type	0xC3	
	6	USINT	Data length	2	
58	1	UINT	Calibration deviation, channel 4	0	-100.00...100.00%
	2	USINT	Link path length	6	
	3	EPATH	Link path	20 0F 24 3A30 01	
	4	WORD	Descriptor	0x0010	
	5	USINT	Data type	0xC3	
	6	USINT	Data length	2	
59	1	UINT	Calibration deviation, channel 5	0	-100.00...100.00%
	2	USINT	Link path length	6	
	3	EPATH	Link path	20 0F 24 3B 30 01	
	4	WORD	Descriptor	0x0010	
	5	USINT	Data type	0xC3	
	6	USINT	Data length	2	

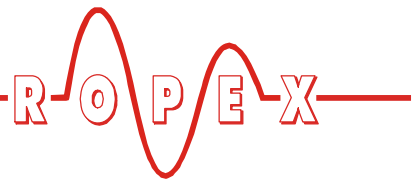

Instance	Attribute ID	Data type ¹	Name	Default value	Value range
60	1	UINT	Calibration deviation, channel 6	0	-100.00...100.00%
	2	USINT	Link path length	6	
	3	EPATH	Link path	20 0F 24 3C 30 01	
	4	WORD	Descriptor	0x0010	
	5	USINT	Data type	0xC3	
	6	USINT	Data length	2	
61	1	UINT	Calibration deviation, channel 7	0	-100.00...100.00%
	2	USINT	Link path length	6	
	3	EPATH	Link path	20 0F 24 3D 30 01	
	4	WORD	Descriptor	0x0010	
	5	USINT	Data type	0xC3	
	6	USINT	Data length	2	

- 1. USINT: Unsigned short integer (8-bit value, unsigned)
- SINT: Short integer (8-bit value, signed)
- UINT: Unsigned integer (16-bit value, unsigned)
- BOOL: 1-bit value
- WORD: 16-bit value
- EPATH: CIP path segment

Changes to one or more instances are normally only temporary, i.e. they are undone again when the supply voltage is interrupted. All write protected instances with the descriptors 0x0010 are an exception (these cannot be changed); the same applies to the instances for the time (31), date (32), and clearable counters (35...43). Changes to these instances take effect immediately and are also effective the next time the device is switched on.

However, changes to other instances can be saved in a retentive memory area of the controller using the CIP "Save (0x16)" service, in which case the values are restored after the supply voltage is reconnected. The CIP "Restore (0x15)" service allows you to load stored values back from the retentive memory area to the temporary memory again at any time in order to undo unwanted changes.

The CIP "Reset (0x05)" service resets all instances of the parameter object to their default values. This applies to both temporary (volatile) and retentive objects.

The "Save", "Restore", and "Reset" services can only be applied to the class (instance 0). All instances of the

parameter object concerned are simultaneously saved or restored.

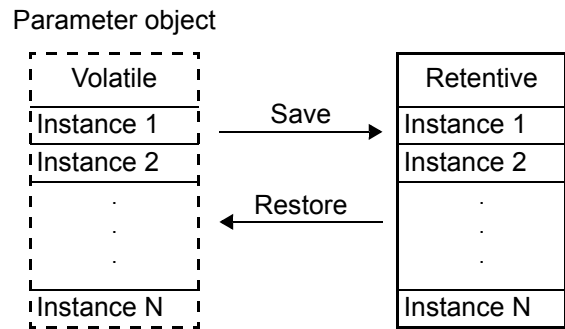

⚠ When the controller is switched on, the last values saved in the retentive parameter object are automatically restored.

⚠ If the controller needs to be replaced, you must load the old parameter data into the new controller using a suitable network configuration tool and then run the "Save" service.

 The parameter object is also reset to the default values if a type 1 reset is triggered on the identity object (class 1).

6.7.1 Temperature range and alloy

This parameter determines both the temperature range and the heatsealing band alloy. You can overwrite the setting of the rotary coding switch (↪ section 5.2.2 "Configuration of the rotary coding switch for the temperature range and alloy" on page 13) by changing the default value (10).

Value	Temperature range	Alloy
0	300°C	TCR = 1700 ppm/K, e.g. CIRUS
4	500°C	TCR = 1700 ppm/K, e.g. CIRUS
9	PC setting (visualization software)	PC setting (visualization software)
10	Rotary coding switch setting	Rotary coding switch setting
11	Variable: Parameter instance 11 is used.	Variable: Parameter instance 10 is used.

By setting this parameter to 11, you apply the value stored in instance 11, attribute 1, to the temperature range and the value stored in instance 10, attribute 1, to the alloy.

 You must always execute the "AUTOCAL" function after changing the "Temperature range / alloy", "Temperature range", or "Temperature coefficient" parameter.

6.7.2 Low temperature OK threshold

Low threshold value for the "OK" window. Refer to section 6.6.6 "Temperature OK (TO)" on page 22 and section 6.7.10 "Temperature diagnosis" on page 39.

6.7.3 High temperature OK threshold

High threshold value for the "OK" window. Refer to section 6.6.6 "Temperature OK (TO)" on page 22 and section 6.7.10 "Temperature diagnosis" on page 39.

6.7.4 Variable calibration temperature

The calibration temperature is set to 20°C by default. You can change it to another value between 0°C and 40°C in order to adapt it to the temperature of the cold heating element.

Some EtherNet/IP™ scanners do not allow the parameter data to be changed during operation. In this case, the calibration temperature cannot be adapted to the actual ambient conditions in the machines.

The calibration temperature can thus be enabled for setting by means of the input data by specifying the value "-1" in the parameter data. The calibration temperature can then be specified via the "Set point / AC temperature" input data (↪ section 6.5.1 "Automatic zero calibration "AUTOCAL" (AC)" on page 19).

You do not need to run the "AUTOCAL" function after changing the calibration temperature.

6.7.5 Heating time limit

The heating time limit provides additional protection against unwanted continuous heating. The controller automatically deactivates the heating impulse after the set heating time limit has elapsed if the start bit remains set for longer than the time specified with this limit. The start bit must be reset before the controller can be started up again.

The heating time limit is activated by default (5.00 s) but can be set to any value between 0 s and 9.99 s (0 and 999).

6.7.6 Measuring impulse duration

The length of the measuring impulses generated by the controller can be set with the parameter at index 10. It may be necessary to set a measuring impulse longer than the default 1.7 ms for certain applications.

6.7.7 Data format

This parameter specifies the order of the bytes ("Little Endian (Intel)" or "Big Endian (Motorola)") in the cyclic data; this setting applies to both input and output data (↪ section 6.4 "Communication protocol" on page 19). We recommend selecting "Big Endian (Motorola)" for Siemens PLCs.

6.7.8 Correction factor Co

The correction factor Co allows you to adapt the controller to the actual conditions in the machine (type of UPT heating element, impulse transformer specification, length of connecting cables, cooling etc.). You can set the required correction factor with this parameter.

Proceed as follows to determine the optimum correction factor C_o :

1. Controller settings:
 - Set temperature: 160...180°C
 - Sealing time: 0.20...0.30 s
2. Heating impulses ("ST" bit = 1):
 Proceed as described in section 6.5.2 "Start (ST)" on page 20.

Slowly increase the correction factor, starting either with the lowest value (50%) or with the value recommended in the ROPEX Application Report minus 25%, until the actual temperature at the end of the heating impulse corresponds to the set temperature. The correction factor should be checked, and if necessary corrected, whenever the machine is operated or the set temperature or the sealing time is changed.

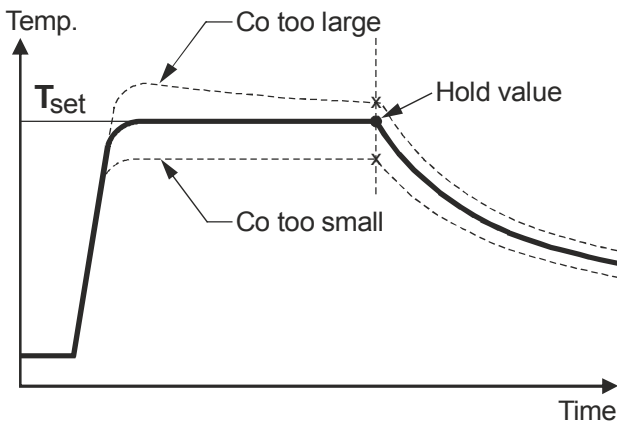

6.7.9 Maximum start temperature

You can set the required maximum start temperature in the parameter data. This temperature is the maximum allowable actual value at the start time. The value is determined by the controller at the start of each impulse and compared with the set value.

This function serves to monitor the cooling circuit.

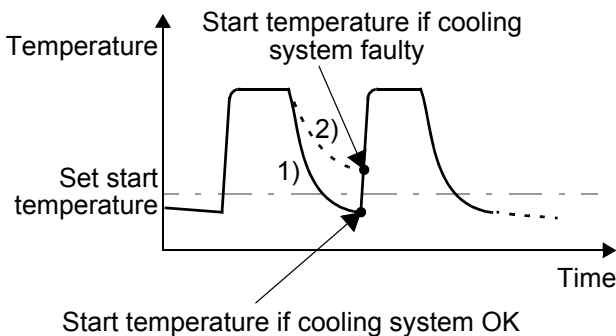

If the cooling system is intact, curve 1) applies. If the cooling system is faulty, curve 2) applies instead

because the water is no longer cooled. The temperature never falls below the value set with this menu step. In this case, the controller ignores the next heatup command. Error code 305 appears and the alarm relay is switched (↪ section 6.19 "Error messages" on page 46). The idea is to prevent the UPT sealing bar from being destroyed.

The maximum value of the setting range is limited by the specified maximum value and the set temperature range. Both values are selected in the parameter data. Setting:

It is advisable not to set this parameter until you have determined the optimum heatsealing parameters (temperature and cooling time) for production. The start temperature should be set to approximately 50% of the heatsealing temperature for the trial run, to enable the optimum working parameters to be established correctly.

6.7.10 Temperature diagnosis

An additional temperature diagnosis can be activated in the parameter data (EDS file). The UPT-6011 checks whether the actual temperature is within a settable tolerance band ("OK" window) either side of the set temperature. The high ($\Delta\vartheta_{high}$) and low ($\Delta\vartheta_{low}$) tolerance limits are the same as for the "Temperature OK" function ("TO" bit ↪ section 6.6.6 "Temperature OK (TO)" on page 22). The limits are set to -10 K and +10 K by default.

If the ACTUAL temperature is inside the specified tolerance band when the "START" signal is activated, the temperature diagnosis is activated as well. If the ACTUAL temperature leaves the tolerance band, the corresponding error code (307, 308) appears and the alarm relay is switched (↪ section 6.19 "Error messages" on page 46).

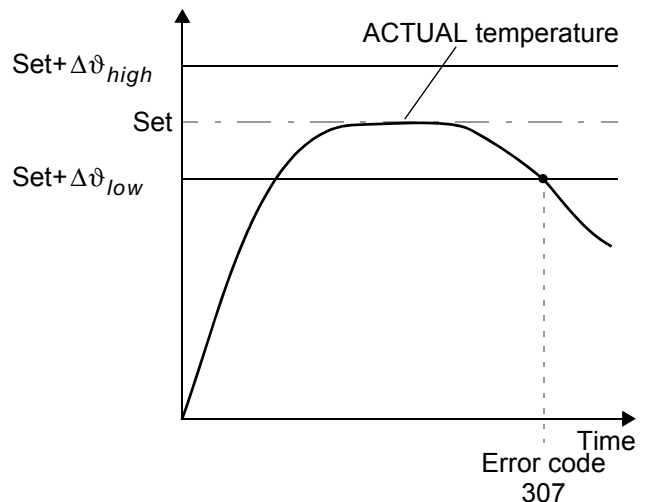

If the temperature diagnosis is not activated by the time the "START" signal is deactivated (i.e. if the ACTUAL temperature does not exceed the high or low tolerance limit), the corresponding error code (309, 310) appears and the alarm relay is switched.

An additional delay time (0..9.99 s) can be set in the parameter data (EDS file). The first time the low tolerance limit is exceeded, the temperature diagnosis is not activated until the configured delay time has elapsed. The temperature diagnosis function can thus be selectively deactivated, e.g. if the temperature drops temporarily owing to the closure of the sealing jaws.

The high and low tolerance limits cannot be set in the ROPEX visualization software. The same limits apply as with the "TO" bit. They can only be set in the parameter data (↪ section 6.7 "Parameter object (class: 0x0F)" on page 23).

6.7.11 Heatup timeout

An additional heatup timeout can be activated in the parameter data (EDS file).

This timeout starts when the "ST" bit is set. The UPT-6011 then monitors the time required for the ACTUAL temperature to reach 95% of the SET temperature. If this time is longer than the configured time, the corresponding error code (304) appears and the alarm relay is switched (↪ section 6.19 "Error messages" on page 46).

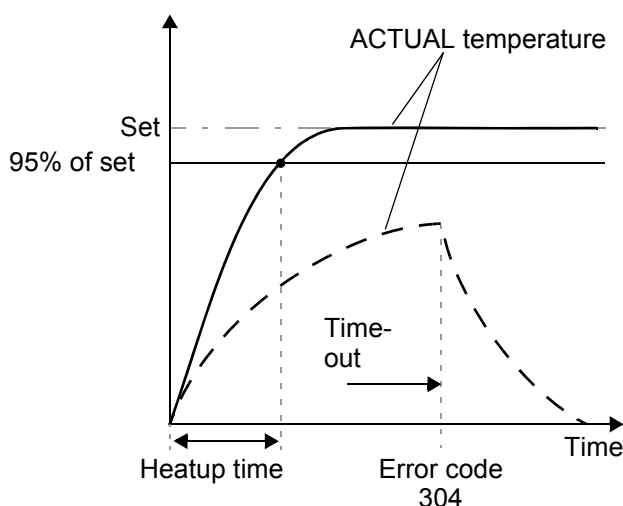

The "Heatup timeout" function must be enabled for use in the parameter data (↪ section 6.7 "Parameter object (class: 0x0F)" on page 23) (default setting: heatup timeout off).

6.7.12 Hold mode

The ACTUAL temperature output via the EtherNet/IP™ protocol can be configured in the parameter data (EDS file) as follows:

1. "Off" (factory setting)

The ACTUAL temperature is always output in real time.

2. "On"

The ACTUAL temperature that was valid at the end of the last heatsealing phase is output. When the controller is switched on, the real ACTUAL temperature is indicated up until the end of the first heating phase.

3. "2 s"

This setting causes the current ACTUAL temperature to be output for an additional 2 seconds by means of the EtherNet/IP™ protocol at the end of a heatsealing phase. The ACTUAL temperature is then output again in real time until the end of the next heatsealing phase.

Hold mode only applies to the ACTUAL temperature which is output via the EtherNet/IP™ protocol and the digital temperature display in the ROPEX visualization software. It has no effect on the ACTUAL temperature that appears at the controller's analog output or is plotted in the graphics window of the ROPEX visualization software.

The various hold modes are shown below:

"ST" bit

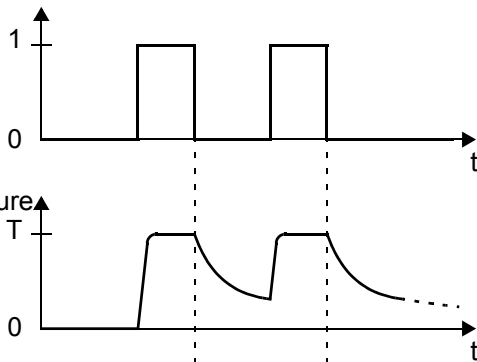

ACTUAL indication

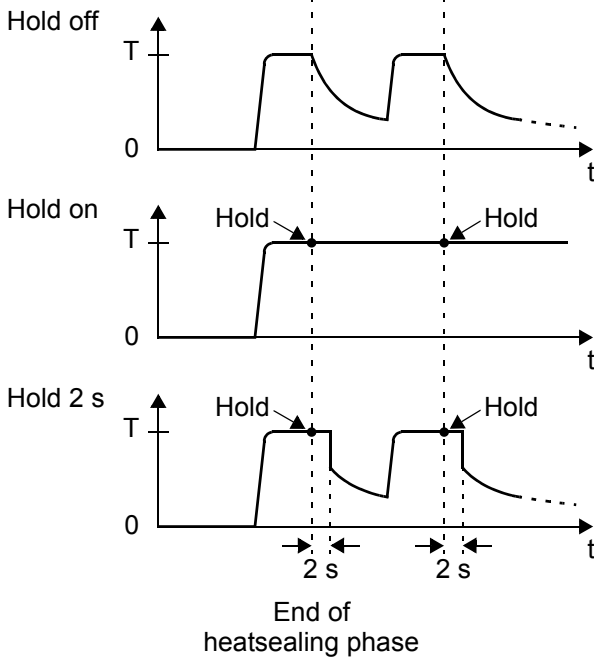

The "Hold mode" function must be activated in the parameter data (↪ section 6.7 "Parameter object (class: 0x0F)" on page 23) (default setting: hold mode off).

6.8 Integrated web server

The integrated web server enables quick and easy access to status information and parameter values of the temperature controller via the existing Ethernet connection. The device protocol can additionally be read out and displayed. A graph showing the last 10 seconds of a heating impulse allows a rapid qualitative evaluation of the controlled system.

The latest version of the operating instructions can be downloaded from the ROPEX website by clicking on the picture of the device on any page. To make sure this latest version is always available in any selectable language, the instructions are not stored in the device; you must therefore have an Internet connection in order to access the operating instructions.

You can go direct to the official ROPEX website by clicking on the ROPEX logo in the top right-hand corner.

The web server uses JavaScript and has been successfully tested with Internet Explorer 9, 10, and 11 as well as with Microsoft Edge. It also works with the latest version of the Safari and Firefox browsers.

6.8.1 Home page

This page contains general product information under "Device Information", for instance the product name, serial number, firmware version, MAC address, and real-time Ethernet protocol. You can also download the correct device description file for your product here (↪ section 6.3 "Device description file (EDS)" on page 18). No Internet connection is necessary to do this because the file is already stored in the device's internal memory.

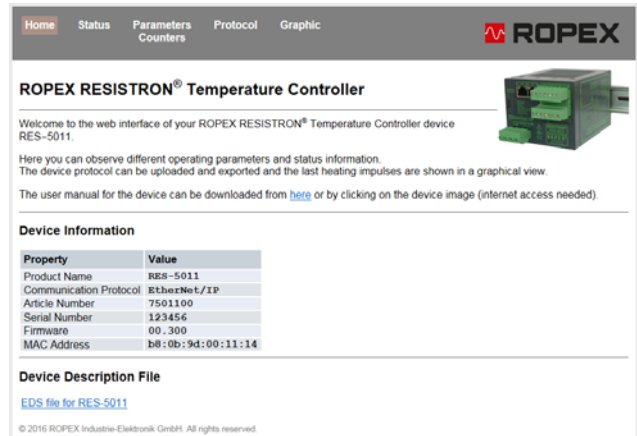

6.8.2 Status page

This page provides an overview of the current controller status.

"Online" indicates whether a connection has been set up to the PLC.

The inputs (↪ section 6.5 "Input data" on page 19) are shown in the left-hand column, the outputs (↪ section 6.6 "Output data" on page 21) in the middle column, and the current status of all device LEDs

(↩ section 6.1 "LEDs and controls" on page 16) in the right-hand column.

6.8.3 Parameters / Counters page

This page shows all parameter values received by the temperature controller from the EtherNet/IP™ scanner. If the parameters have been changed using acyclic services, these changes are also indicated here.

For the meanings of the parameter data, refer to section 6.7 "Parameter object (class: 0x0F)" on page 23.

Under "Counters" you see a list of all cycle and operating hours counters, which are useful for statistical purposes.

6.8.4 Protocol page

You can download and display the device protocol for the temperature controller on this page. You see the

overall size of the protocol ("Total event entries") as well as the upload progress. All entries appear in the form of a table. A timestamp (generated by the built-in clock), the operating hours and cycle counters, and the channel selected at the time are shown for each entry. In addition to errors, the protocol also contains entries of general interest such as "Clock set" or the "AUTOCAL" function. An error code provides information on the cause of all events in the protocol. The error codes are described in detail in section 6.19 "Error messages" on page 46. Each error code is explained in a tooltip when you hover over it briefly.

The data can also be exported to a CSV file to enable further processing in another software program. By clicking on the appropriate button you can select a comma separated format or a semicolon separated format.

The download may take a few seconds, depending on the number of entries which are stored here. The newest events appear at the top of the list.

If any new events occur while this page is displayed, you do not see them until you refresh the list by clicking on the "Protocol" menu again.

6.8.5 Graphic page

The temperature controller has an internal memory which can store temperature curves over a period of up to 10 seconds. This memory is automatically filled when the "ST" bit is set. You can display or export the memory contents on the Graphic page.

By clicking on "Refresh", you cause the graphic data to be downloaded from the memory of the temperature controller and displayed again.

"Clear" clears all data from the memory (disconnecting the 24 VDC supply voltage has the same effect).

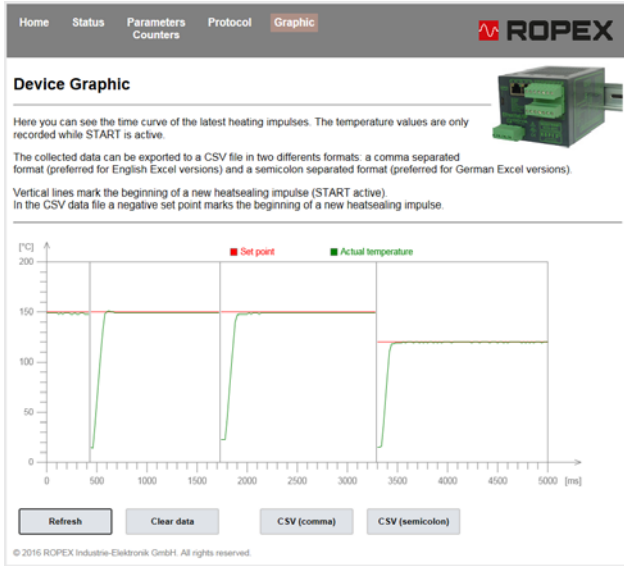

The vertical lines mark the beginning of a new heatsealing impulse ("ST" bit set). A negative set point indicates the start of a new impulse in the exported data. Cooling processes are not normally visible because they take place when the "ST" bit is reset.

6.9 Undervoltage detection

Trouble-free operation of the temperature controller is guaranteed within the line voltage and 24 VDC supply voltage tolerances specified in section 8 "Technical data" on page 53.

If the 24 VDC supply voltage drops below the permitted lower limit, the controller is switched to standby mode. No more heatsealing processes take place and no more measuring impulses are generated. Normal operation is resumed when the input voltage returns to the specified tolerance range again.

Standby mode is indicated by 0...3°C (i.e. approx. 0 V) at the analog output. In addition, the "SA" bit is set in the status word for the cyclic output data.

! Trouble-free operation of the controller is only guaranteed within the specified tolerance range of the input voltage. An external voltage monitor must be connected to prevent low line or 24 VDC supply voltage from resulting in defective heatseals.

6.10 Temperature meter(actual value output)

The UPT-6011 supplies an analog 0...10 VDC signal, which is proportional to the real ACTUAL temperature, at terminals 17+18.

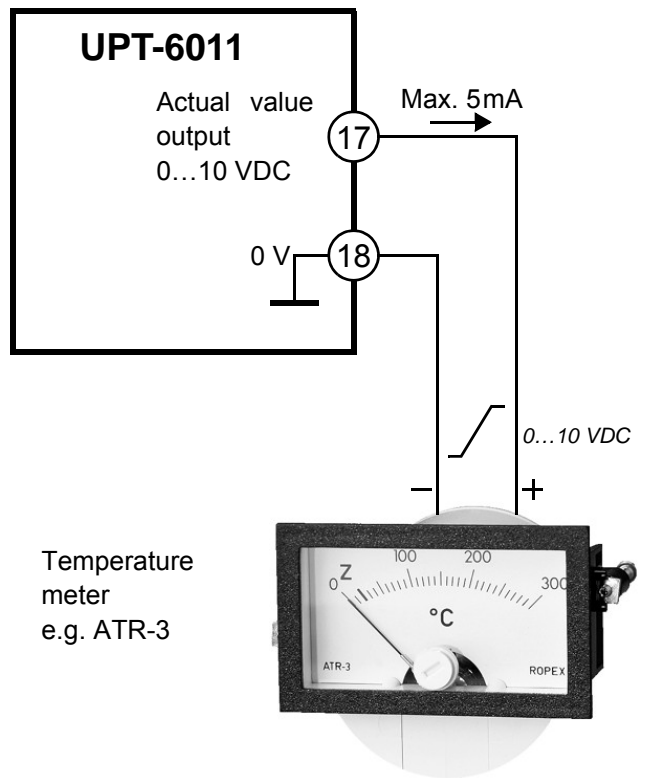

Temperature meter e.g. ATR-3

Voltage values:
 0 VDC → 0°C
 10 VDC → 300°C or 500°C
 (depending on the device configuration)

The relationship between the change in the output voltage and the ACTUAL temperature is linear.

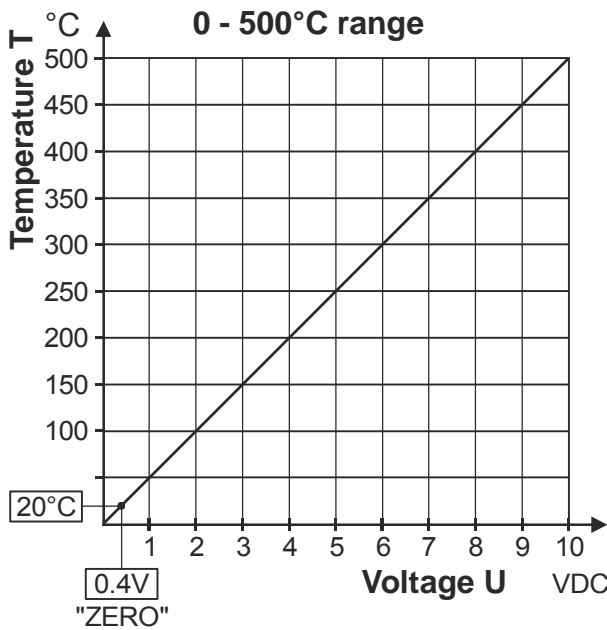
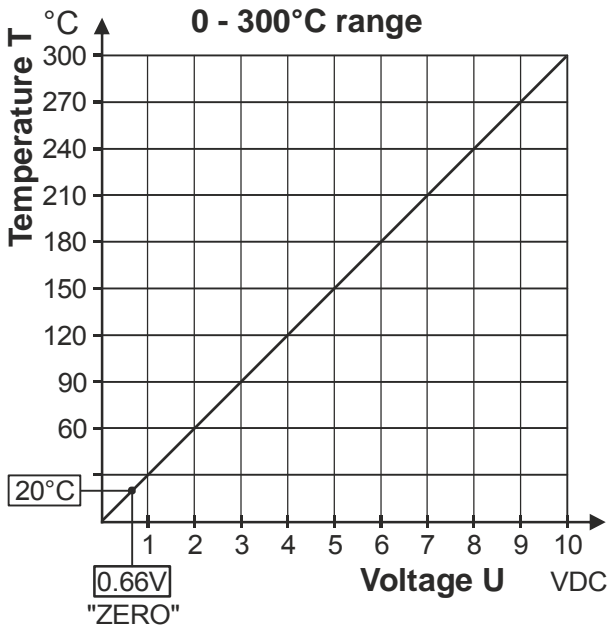

An indicating instrument can be connected to this output in order to visualize the temperature of the heating element.

The ROPEX ATR-x temperature meter is optimally adapted to this application in every respect (size, scale, dynamic behavior), which is why this particular meter should always be used (see section 10 "Accessories and modifications" on page 55).

The meter not only facilitates SET-ACTUAL comparisons but also enables other criteria such as the heating

rate, set point achieved within the specified time, cooling of the heating element etc. to be evaluated.

The temperature meter additionally permits disturbances in the control loop (loose connections, contacting or wiring problems) as well as any line disturbances to be observed extremely efficiently and interpreted accordingly. The same applies if several neighboring control loops interfere with one another. If a fault is signaled, this analog output is used to display a selective error message (see section 6.19 "Error messages" on page 46).

6.11 Booster connection

The UPT-6011 controller has a connection for an external switching amplifier (booster) as standard. This connection (at terminals 15+16) is necessary for high primary currents (continuous current > 5 A, pulsed current > 25 A). The booster should be connected as described in section 4.7 "Wiring diagram with booster connection" on page 11.

! The connecting cable to the booster must not be longer than 1 m; it must also be twisted in order to reduce EMC interference to a minimum.

6.12 USB interface for visualization software (ROPEXvisual®)

A USB interface (type: Micro USB) is provided for system diagnostics and process visualization. This USB interface enables a data connection to be set up to ROPEXvisual®, the ROPEX visualization software.

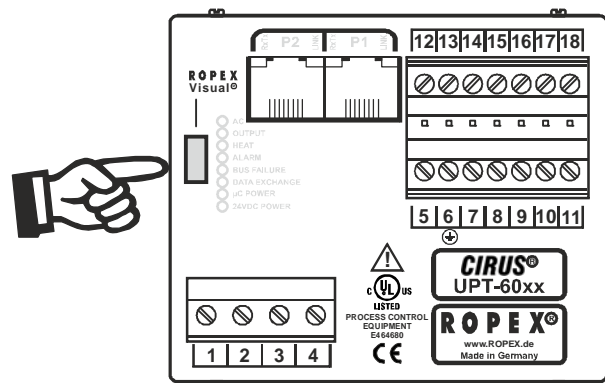

The ROPEX visualization software is described in a separate document.

6.13 AUX interface

Internal interface for diagnostics and maintenance. This interface is not currently available.

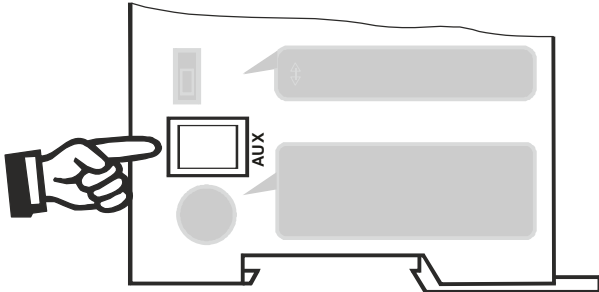

6.14 Total cycle counter

The number of heatsealing cycles executed since the controller was shipped is stored in the internal memory ("ST" bit = 1). This is a read-only counter which cannot be reset. It can be displayed in the ROPEX visualization software (↪ section 6.12 "USB interface for visualization software (ROPEXvisual®)" on page 44), via the integrated web server, or using the acyclic services of the EtherNet/IP™ interface.

6.15 Operating hours counter

The number of operating hours since the controller was shipped is stored in the internal memory. This counter works with a resolution of six minutes. It is a read-only counter which cannot be reset. It can be displayed in the ROPEX visualization software (↪ section 6.12 "USB interface for visualization software (ROPEXvisual®)" on page 44), via the integrated web server, or using the acyclic services of the EtherNet/IP™ interface.

6.16 Data memory for error messages and AUTOCAL

To simplify error diagnoses during operation, the UPT-6011 controller has a data memory for error messages (↪ section 6.19 "Error messages" on page 46) and executed AUTOCAL functions (↪ section 6.5.1 "Automatic zero calibration "AUTOCAL" (AC)" on page 19).

The 400 most recent messages are stored. They can be read out and displayed in the ROPEX visualization software (↪ section 6.12 "USB interface for visualiza-

tion software (ROPEXvisual®)" on page 44) or via the integrated web server.

The UPT-6011 also features a built-in clock (↪ section 6.17 "Built-in clock (date and time)" on page 45). All messages are saved in the data memory together with their date and time of occurrence (timestamp).

6.17 Built-in clock (date and time)

The UPT-6011 has a built-in clock. All messages are saved in the data memory (↪ section 6.16 "Data memory for error messages and AUTOCAL" on page 45) together with their date and time of occurrence (timestamp). Error messages can thus be interpreted more accurately whenever a problem needs to be analyzed.

The built-in clock can be set and read out in the ROPEX visualization software (↪ section 6.12 "USB interface for visualization software (ROPEXvisual®)" on page 44) or using the acyclic services of the EtherNet/IP™ interface. The date and time can be read out but not set via the integrated server.

⚠ A maintenance-free capacitor is used to operate the clock. There is no battery that has to be replaced every now and then.

The controller must remain switched on for at least three hours to make sure the clock's capacitor is fully charged. When the controller is switched off, the fully charged capacitor can keep the clock running for approximately 2...4 weeks. If the controller is switched off for longer, the date and time will have to be set again. You can do this in the ROPEX visualization software (↪ section 6.12 "USB interface for visualization software (ROPEXvisual®)" on page 44) or using the acyclic services of the EtherNet/IP™ interface.

⚠ The capacitor is not charged when it leaves the factory. When the controller is started up, you must set the clock if you want error messages to be saved in the data memory (↪ section 6.16 "Data memory for error messages and AUTOCAL" on page 45) together with their date and time of occurrence.

⚠ The controller can also be operated without the clock. In this case, the dates and times that are saved in the data memory will be invalid (↪ section 6.16 "Data memory for error messages and

AUTOCAL" on page 45) . However, this has no effect on the temperature control functions.

6.18 System monitoring / alarm output

To increase operational safety and avoid faulty heatsealing, this controller incorporates special hardware and software features to facilitate selective error detection and diagnosis. Both the external wiring and the internal system are monitored.

These features significantly assist the operator in identifying the cause of abnormal situations.

A system fault is reported or differentiated by means of the following indications.

A.) Red "ALARM" LED on the controller with three states:

1. Blinking fast (4 Hz):

The "AUTOCAL" function should be executed (error codes 104...106, 211, 302, 303).

2. Blinking slowly (1Hz):

The system configuration is incorrect and the zero calibration ("AUTOCAL" function) was unsuccessful (↪ section 5.2 "Device configuration" on page 12). This corresponds to error codes 111...114).

3. Lit continuously:

A fault is preventing the system from starting (error codes 101...103, 107, 108, 201...203, 304, 305, 307, 308, 9xx).

As a rule, this refers to an external wiring fault.

B.) Alarm relay (relay contact terminals 12+13+14):

This relay is set at the factory as follows:

- **DE-ENERGIZED** in operating states A.1 and A.2 but energized if a "START" signal is present in one of these states.
- **ENERGIZED** in operating state A.3.

If the alarm relay has the opposite configuration to the factory setting (↪ section 5.2.4 "Configuration of the alarm relay" on page 14), these states are reversed.

C.) Error code indicated via the EtherNet/IP™ protocol:

If an error occurs, the "AL" bit is set and possibly also the "WA" bit. The error code is contained in the third word at bit positions 0...9 (↪ section 6.6.11 "All 16 bits of the first word must be interpreted as a signed number

(two's complement notation). The resolution is 1°C. During the calibration procedure or if a fault occurs, the actual value is 0. Error codes" on page 23).

D.) Error code indicated via the actual value output 0...10 VDC (terminals 17+18):

Since a temperature indication is no longer necessary if a fault occurs, the actual value output is used to display error messages whenever a fault is signaled.

Thirteen voltage levels are available for this purpose in the 0...10 VDC range, each of which is assigned an error code (↪ section 6.19 "Error messages" on page 46).

If a state that requires AUTOCAL occurs – or if the device configuration is incorrect – (error codes 104...106, 111...114, 211, 302, 303), the signal at the actual value output jumps back and forth at 1 Hz between the voltage value corresponding to the error and the end of the scale (10 VDC, i.e. 300°C or 500°C). If the "START" signal is present in one of these states, the voltage value does not change any more.

If a ROPEX temperature meter (e.g. an ATR-x) is connected to the controller's analog output, the temperature indication can be directly assigned to the error codes if an alarm is signaled.

An error message can be reset by setting the "RS" bit or by momentarily interrupting the power to the controller (24 VDC supply voltage).

If an error message is reset with the "RS" bit, it is not actually reset until the "RS" bit is reset.

Invalid error messages may appear when the controller is switched off owing to the undefined operating state. This must be taken into account when they are evaluated by the higher-level controller (e.g. a PLC) in order to avoid false alarms.

6.19 Error messages

The table below shows the meaning of the error codes. It includes a description of each error as well as the required corrective action.

The block diagram in section 6.20 "Fault areas and causes" on page 50 helps you clear a particular error quickly and efficiently.

Thirteen voltage levels for diagnosing errors appear at the controller's actual value output. The error messages are even more finely differentiated internally. The 3-digit error codes described below can be displayed via the EtherNet/IP™ interface or in the ROPEX visualization software (↪ section 6.12 "USB interface

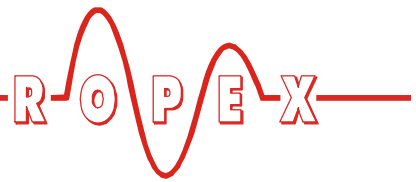

for visualization software (ROPEXvisual®) on page 44) to facilitate troubleshooting).



If the actual value output is evaluated in order to identify an error message – in the higher-

level controller, for instance – the tolerance window must be adjusted to prevent incorrect interpretations. Please note the tolerances of the actual value output (↪ section 8 "Technical data" on page 53).

Part 1 of 3: Error messages (faults)

NOTE: The error messages shown here are output as faults (constant error voltage at actual value output, alarm LED lit continuously, alarm relay energized).

Error code	Act. val. output voltage [V]	Cause	Action if machine started for first time	Action if machine already operated, HS band not changed
101	0.66	No current signal	Fault area ①	Fault area ①
102	1.33	No voltage signal	Fault area ③	Fault area ③
103	2.00	No current / voltage signals	Fault area ②	Fault areas ② ⑨
107	2.66	Temperature step, down	Fault areas ④ ⑤ ⑥ ("loose contact")	Fault areas ④ ⑤ ⑥ ("loose contact")
108		Temperature step, up		
307		Temperature too high / low (↪ section 6.7.10)		
308				
309				
310				
201	3.33	No line frequency / line frequency fluctuates	Check power supply	Check power supply
202		Line frequency too high / fluctuates		
203		Line frequency too low / fluctuates		
304	4.00	Heatup time too long (↪ section 6.7.11)	Perform RESET	Perform RESET
305		Start temperature too high (↪ section 6.7.9)		
901	4.66	No line voltage / sync signal	↪ Section 6.2	↪ Section 6.2
913		Triac defective	Replace device	Replace device
914		Internal fault, device defective	Replace device	Replace device
915				
916				
917		Jumper for alarm output incorrect	Check jumper	Check jumper
918				

Part 2 of 3: Error messages (warnings)

NOTE: The specified error messages are initially output as warnings (actual value output jumps back and forth between two values, alarm LED blinks, alarm relay de-energized). When the "START" signal is activated, the warning changes to a fault (actual value output no longer jumps back and forth, see ***bold italic values***, alarm LED lit continuously, alarm relay energized).

Error code	Act. val. output voltage [V]	Cause	Action if machine started for first time	Action if machine already operated, HS band not changed
104	↔ 5.33 ↔ ↔ 10 ↔	Current signal incorrect, incorrect impulse transformer specification	Perform AUTOCAL , check transformer specification, fault areas ⑦ ⑧	Fault areas ④ ⑤ ⑥ ("loose contact")
105		Voltage signal incorrect, incorrect impulse transformer specification		
106		Current and voltage signals incorrect, incorrect impulse transformer specification		
302		Temperature too low, calibration not performed, loose contact, ambient temp. fluctuates	Perform AUTOCAL and / or fault areas ④ ⑤ ⑥ ("loose contact")	
303		Temperature too high, calibration not performed, loose contact, ambient temp. fluctuates		
211	↔ 6.00 ↔ ↔ 10 ↔	Data error	Perform AUTOCAL	Perform AUTOCAL

Part 3 of 3: Error messages (warnings)

NOTE: The specified error messages are initially output as warnings (actual value output jumps back and forth between two values, alarm LED blinks, alarm relay de-energized). When the "START" signal is activated, the warning changes to a fault (actual value output no longer jumps back and forth, see **bold italic values**, alarm LED lit continuously, alarm relay energized).

Error code	Act. val. output voltage [V]	Cause	Action if machine started for first time	Action if machine already operated, HS band not changed
111	↔ 6.66 ↔ ↔ 10 ↔	Current signal incorrect, no calibration possible	Fault area ⑧, check configuration	Fault areas ④ ⑤ ⑥ ("loose contact")
112	↔ 7.33 ↔ ↔ 10 ↔	Voltage signal incorrect, no calibration possible	Fault area ⑦, check configuration	Fault areas ④ ⑤ ⑥ ("loose contact")
113	↔ 8.00 ↔ ↔ 10 ↔	Current / voltage signals incorrect, no calibration possible	Fault area ⑦ ⑧, check configuration	Fault areas ④ ⑤ ⑥ ("loose contact")
114		Temperature fluctuates, no calibration possible	Perform AUTOCAL and / or fault areas ④ ⑤ ⑥ ("loose contact")	Perform AUTOCAL and / or fault areas ④ ⑤ ⑥ ("loose contact")
115	↔ 8.66 ↔ ↔ 10 ↔	Ext. calibration temp. too high, no calibration possible	Perform AUTOCAL with ext. calibration temperature ≤40°C	Perform AUTOCAL with ext. calibration temperature ≤40°C
116		Ext. calibration temp. fluctuates, no calibration possible	Perform AUTOCAL with stable ext. calibration temperature	Perform AUTOCAL with stable ext. calibration temperature

6.20 Fault areas and causes

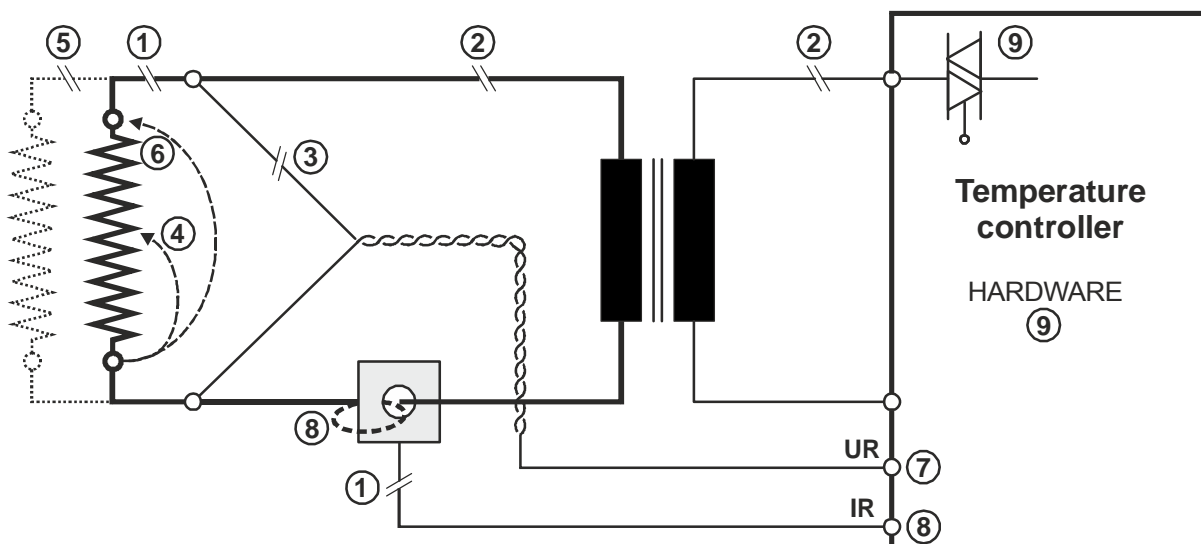



The table below explains the possible fault causes.

Fault area	Explanation	Possible causes
①	Load circuit interrupted after U_R pickoff point	- Wire break, heatsealing band break - Contact to heatsealing band is defective
	PEX-W2/-W3 current transformer signal interrupted	- I_R measurement cable from current transformer interrupted
②	Primary circuit interrupted	- Wire break, triac in controller defective - Primary winding of impulse transformer interrupted - Kb contactor open
	Secondary circuit interrupted before U_R pickoff point	- Wire break - Secondary winding of impulse transformer interrupted
③	No U_R signal	- Measurement cable interrupted
④	Partial short-circuit (delta R)	- Heatsealing band partially bypassed by conducting part (clamp, opposite heatsealing bar etc.)
⑤	Parallel circuit interrupted	- Wire break, heatsealing band break - Contact to heatsealing band is defective
⑥	Total short-circuit	- Heatsealing band incorrectly installed, no insulation at heatsealing bar ends or insulation incorrectly installed - Heatsealing band completely bypassed by conducting part
⑦	U_R signal incorrect	- U_2 outside of permissible range from 0.4...120 VAC
⑧	I_R signal incorrect	- I_2 outside of permissible range from 30...500 A
	Wire incorrectly laid through PEX-W2/-W3 current transformer	- Check number of turns (two or more turns required for currents < 30 A)
⑨	Internal device fault / no line voltage	- Hardware fault (replace controller) - Jumper for alarm relay not connected or incorrectly connected - No line voltage

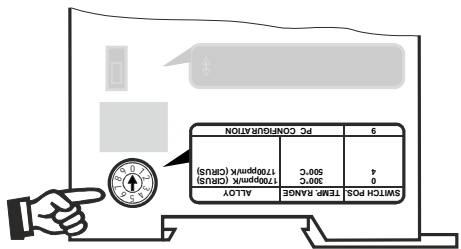

7 Factory settings

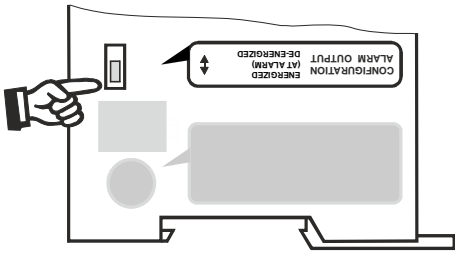

The CIRUS[®] UPT-6011 temperature controller is configured at the factory as follows:

<p><u>Rotary coding switch</u> for heatsealing band alloy and temperature range</p>		<p>Heatsealing band alloy: 1700 ppm/K Temperature range: 300°C</p> <p>Rotary coding switch: "0" position</p>
---	---	--

<p><u>Slide switch</u> for alarm relay</p>		<p>Alarm relay energized at alarm</p>
<p><u>Temperature diagnosis</u></p>		<p>Temperature diagnosis: Off</p>
<p><u>Heatup timeout</u></p>		<p>Heatup timeout: Off</p>

8 Technical data

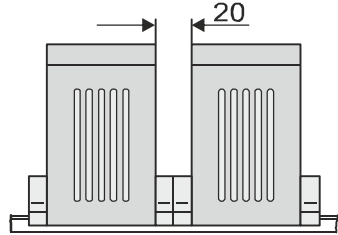
Type of construction	Housing for installation in an electrical cabinet Snaps onto a standard top hat rail (TS35 rail, 35 mm) acc. to DIN EN 50022 Dimensions: 90 x 75mm; height: 135 mm (incl. terminals)
Line voltage	110 VAC -15%...300 VAC +10% (equivalent to 94...330 VAC) Connected between neutral conductor and one line conductor or 110 VAC -15%...415 VAC +10% (equivalent to 94...456 VAC) Connected between two line conductors  The voltage between the line conductor and ground must not be more than 300 VAC.
Power supply system	Balanced TN or TT system, max. 415 VAC Installation category III  Operation in potential-free systems (e.g. an IT system) is only permitted after consultation with ROPEX.
Line frequency	47...63 Hz, automatic adjustment to frequencies in this range
Current consumption (primary current of impulse transformer)	$I_{\max} = 5\text{ A}$ (duty cycle = 100%) $I_{\max} = 25\text{ A}$ (duty cycle = 20%, cycle duration 1 min)
24 VDC supply voltage Terminals 5+7	24 VDC, $I_{\max} = 200\text{ mA}$ Tolerance: $\pm 10\%$ SELV or PELV supplied from max. 300 VAC, Cat II
Measuring range	Secondary voltage U_R : 0.4...120 VAC Secondary current I_R : 30...500 A (with PEX-W2/-W3/-W4 current transformer) ↳ ROPEX Application Report
EtherNet/IP™ interface	2 Ethernet switch ports RJ45 Wiring: IEC 61784-5-3 Data transfer rate: 10 or 100 MHz Data transport layer: Ethernet II, IEEE 802.3 Addressing: DHCP or selectable with rotary coding switch ACD and DLR support: Yes
Heatsealing band type and temperature range	The temperature range and temperature coefficient settings can also be specified in the ROPEX visualization software (↳ section 6.12 "USB interface for visualization software (ROPEXvisual®)" on page 44) in addition to using the rotary coding switch or via the EtherNet/IP™ interface (see below): Temperature range: 200°C, 300°C, 400°C, or 500°C Temperature coefficient: 400...4000 ppm/K (variable setting range) Two different ranges can be set using the rotary coding switch or via the EtherNet/IP™ interface: Temperature coefficient 1700 ppm/K, 0...300°C (CIRUS) Temperature coefficient 1700 ppm/K, 0...500°C (CIRUS)

Analog output (actual value) Terminals 17+18	0...10 VDC, $I_{\max} = 5 \text{ mA}$ Equivalent to 0...300°C or 0...500°C Accuracy: $\pm 1\%$ plus 50 mV
Alarm relay Terminals 12, 13, 14	$U_{\max} = 30 \text{ V (DC/AC)}$, $I_{\max} = 0.2 \text{ A}$, changeover contact, potential-free
Power loss	Max. 20 W
Ambient conditions	Max. altitude: 2000 m Ambient temperature: +5...+45°C Max. relative humidity: 80% at temperatures up to +31°C, decreasing linearly to 50% relative humidity at +45°C
Degree of protection	IP20
UL file	E464680
Installation	<p>A minimum safety clearance of 20 mm all round (e.g. from other devices and wiring) must be allowed when installing the device.</p> <p>The moving clip required for fastening must be facing down for mounting on a horizontal top hat rail.</p> <p>End holders to mechanically fix the controller must be fitted at both ends for mounting on a vertical top hat rail.</p> 
Weight	Approx. 0.5 kg (incl. connector plug-in parts)
Housing material	Plastic, polycarbonate, UL-94-V0
Connecting cable Type / cross-sections	Rigid or flexible; 0.2...2.5 mm ² (AWG 24...12) Plug-in connectors Plug-in connectors: Tightening torque: 0.5...0.6 Nm (screwdriver: SZS 0.6x3.5 mm)  If ferrules are used, they must be crimped in accordance with DIN 46228 and IEC / EN 60947-1. This is essential to ensure proper electrical contact in the terminals.

9 Dimensions

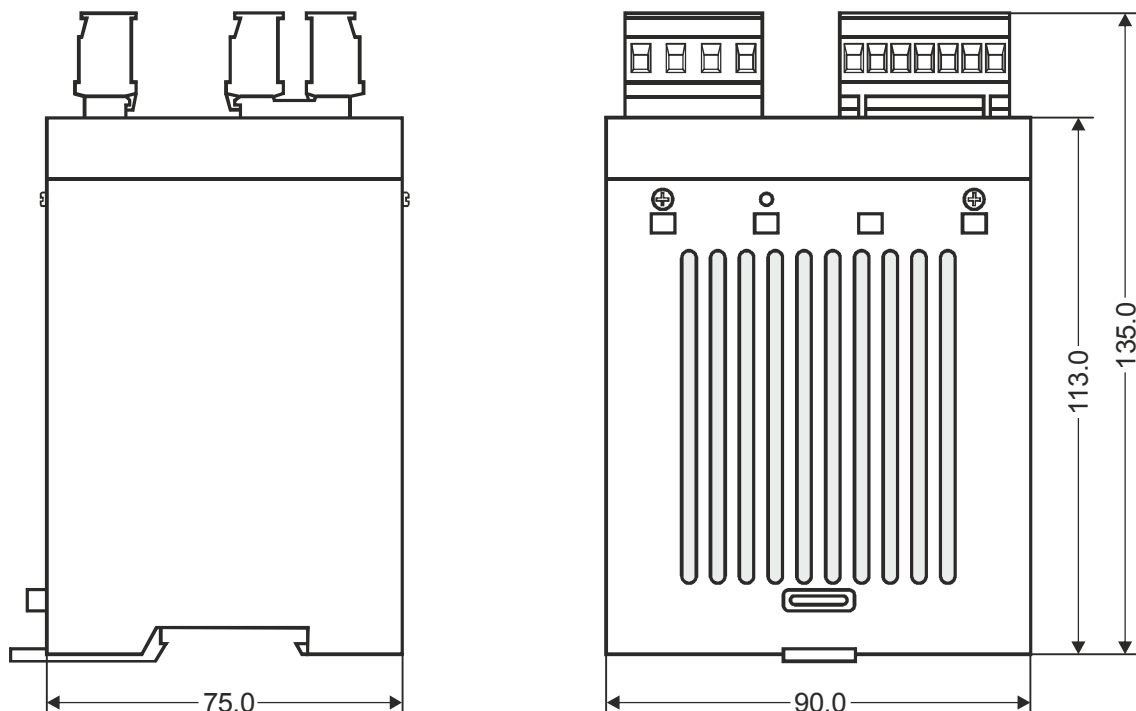







10 Accessories and modifications

A wide range of compatible accessories and peripheral devices are available for the CIRUS UPT-6011 temperature controller. They allow it to be optimally adapted to your specific heatsealing application as well as to the design and operating philosophy of your system.

10.1 Accessories

The products described below are only a few of the wide range of accessories available for CIRUS temperature controllers.

	<p>Analog temperature meter ATR-x For front panel mounting or mounting on a top hat rail (DIN TS35 rail). Analog indication of the ACTUAL heatsealing band temperature in °C. The meter damping of the unit is optimized for the abrupt temperature changes that occur in impulse mode.</p>
	<p>Line filter LF-xx480 Essential to ensure CE conformity. Optimized for CIRUS temperature controllers.</p>

	<p>Impulse transformer TR-x Designed according to VDE 0570 / EN 61558 with a one-section bobbin. Optimized for impulse operation with CIRUS temperature controllers. Specified according to the heatsealing application (↪ ROPEX Application Report).</p>
	<p>Booster External switching amplifier, necessary for high primary currents (continuous current > 5 A, pulsed current > 25 A)</p>
	<p>Current transformer PEX-W3/W4 Essential for measuring the secondary current. The PEX-W4 current transformer also has UL approval.</p>
	<p>Monitoring current transformer MSW For detecting frame short-circuits at the heatsealing band. Used as an alternative to the standard PEX-W2/-W3 current transformer.</p>
	<p>U_R measurement cable UML-1 Twisted cable for measuring the U_R voltage. Suitable for drag chains; contains neither halogens nor silicone.</p>

10.2 Modifications (MODs)







Owing to its universal design, the CIRUS UPT-6011 temperature controller is suitable for a very wide range of heatsealing applications.

One modification (MOD) is available for the CIRUS UPT-6011 temperature controller for implementing special applications.

MOD 01

Booster for low secondary voltages ($U_R = 0.2 \dots 60 \text{ VAC}$). This modification is necessary, for example, for very short or low-resistance heating elements.

11 How to order

	<p>Controller UPT - 6011 Power supply 115...400 VAC, Art. No. 7601100</p> <p>Scope of supply: Controller includes connector plug-in parts (without current transformer)</p> <p>Modification MOD . . (optional, if required) e.g. → 01: MOD 01, Art. No. 800001 (booster for low voltage)</p> <p>Please indicate the article numbers of the controller and the required modifications (optional) in all orders, e.g. UPT-6011 + MOD 01 (controller with booster for low voltage) Art Nos. 7601100 + 800001 must be ordered</p>
	<p>Current transformer PEX-W . → PEX-W3: Art. No. 885105 PEX-W4: Art. No. 885106</p>
	<p>Line filter LF- . . 480 → 06: Continuous current 6 A, 480 VAC, Art. No. 885500 35: Continuous current 35 A, 480 VAC, Art. No. 885506</p>
	<p>Impulse transformer See ROPEX Application Report for design and ordering information</p>
	<p>Temperature meter ATR - . → 3: 300°C range, Art. No. 882130 5: 500°C range, Art. No. 882150</p>
	<p>Booster B- . . . → 075400: Max. pulse load 75 A, 400 VAC, Art. No. 885301 075415: Max. pulse load 75 A, 415 VAC, Art. No. 885302 100400: Max. pulse load 100 A, 400 VAC, Art. No. 885304</p>

12 Index

Numbers

24 VDC supply voltage 53

A

"AA" bit 22
 "AC" bit 20
 Actual value 23
 Actual value output 43
 "AG" bit 22
 "AL" bit 15, 22
 Alarm output 46
 Alarm relay 14, 54
 Alloy 13
 Altitude 54
 Ambient conditions 54
 Ambient temperature 54
 Analog temperature meter 55
 Application 4
 Application Report 7, 9
 AUTOCAL 15
 Active 22
 Blocked 20, 22
 Starting 20
 Automatic zero calibration 15, 19
 AUX interface 45

B

Booster 6, 11, 56, 57
 Booster connection 44

C

Circuit-breaker 8
 Co (correction factor) 38
 Control active 23
 Correction factor Co 38
 Current transformer 3, 6, 9, 57

D

Data format 38
 Data memory 45
 Date 45
 Degree of protection 54
 Device description file (EDS) 18
 Dimensions 55

E

EDS file 18
 Error code format 39
 Error diagnosis 6
 Error messages 46
 EtherNet/IP interface 53
 External switching amplifier 11, 56

F

Factory settings 51
 Fault 22
 Fault areas 50
 Fuse 8

H

Heating element 3, 4, 14
 Heatsealing band type 53
 Heatup timeout 40

I

Impulse transformer 3, 8, 56, 57
 Input data 19
 Installation 7, 54
 Installation procedure 7
 Installation regulations 7
 Installation steps 7

L

Line filter 3, 8, 9, 55, 57
 Line frequency 53
 Line voltage 53

M

Maintenance 55
 Master AUTOCAL (MA) 21
 Measurement cable 56
 Measurement pause 21
 Measuring impulse duration 38
 Measuring range 53
 Modification MOD 56, 57
 "MP" bit 21

O

Output data 21
 Over-current protection 8

P

PEX-W2/-W3/-W4 3
 PEX-W3 9, 57
 PEX-W4 9
 Power loss 54
 Power supply 8
 Power supply system 53

R

"RA" bit 15, 23
 Relative humidity 54
 Replacing the heating element 14
 Reset 20
 ROPEXvisual 44

"RS" bit 20

S

Set point 21

Standby mode 43

Start 20

"START" bit 15

Start temperature 39

Startup 12, 14

System diagnosis 44

System monitoring 46

T

TCR 14

"TE" bit 22

Temperature achieved 22

Temperature coefficient 14

Temperature diagnosis 39, 40

Temperature meter 44, 55, 57

Temperature OK 22

Temperature range 13, 53

Time 45

Timestamp 45

"TO" bit 22

Transformer 3, 8, 56, 57

Type of construction 53

U

UL file 54

USB interface 44

V

View of the device 12

Visualization software 44

W

Web server 41

Wiring 7, 8

Wiring diagram 10, 11