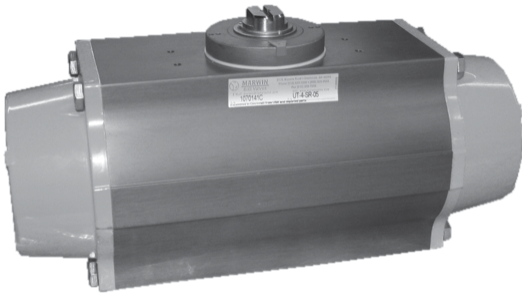

UT-DA Series
UT**-SR Series**

A full range of double acting and spring return actuators designed to NAMUR for air supply ports and top mounting with ISO 5211 for base mounting patterns.

Features

- Dual adjustable open - close stops (UT-0 thru UT-4.5)
- Anti-blowout pinion
- 1,000,000 cycle normal service life
- ISO / DIN Valve Interface
- NAMUR Accessory Mounting
- Long end cap bolts allow spring decompression

Quick Spec	
Product Scope	
Size Range	DA: 0A, 0, 1, 2, 2.5, 3, 3.5, 4, 4.5, 5, 6, 7 SR: 0, 1, 2, 2.5, 3, 3.5, 4, 4.5, 5, 6, 7
Operating Torque Range	DA: 71 to 25469 in-lb @ 80 psi SR: 55 to 9221 in-lb @ 80 psi
Operating Pressure	40 to 115 psig
Casing Pressure	150 psig
Temperature	(NBR standard) -4 to 175°F (opt. high temp. Viton) -4 to 302°F (opt. low temp. HBNR) -40 to 185°F
Media	Air dry or lubricated; noncorrosive gas
Rotation	UT-0 thru UT-4.5: 100° (-5°CW to 5°CW) UT-0A, 5,6,7: 95° (0°CW to 5°CW)
Materials	Casing: Aluminum UNI 6060 Shaft: Steel
Finish	Casing: Hard-coated anodized End Caps: Polyester powder coated
Design Standards	
Thread Design (Port)	ANSI B1.20.1
Mounting Flange (Valve)	ISO 5211
NAMUR Mounting (accessories)	VDI/VDE 3845
ATEX	Atmospheres Explosibles Directive 94/9/EC
PED	Pressure Equipment Directive 97/23/EC

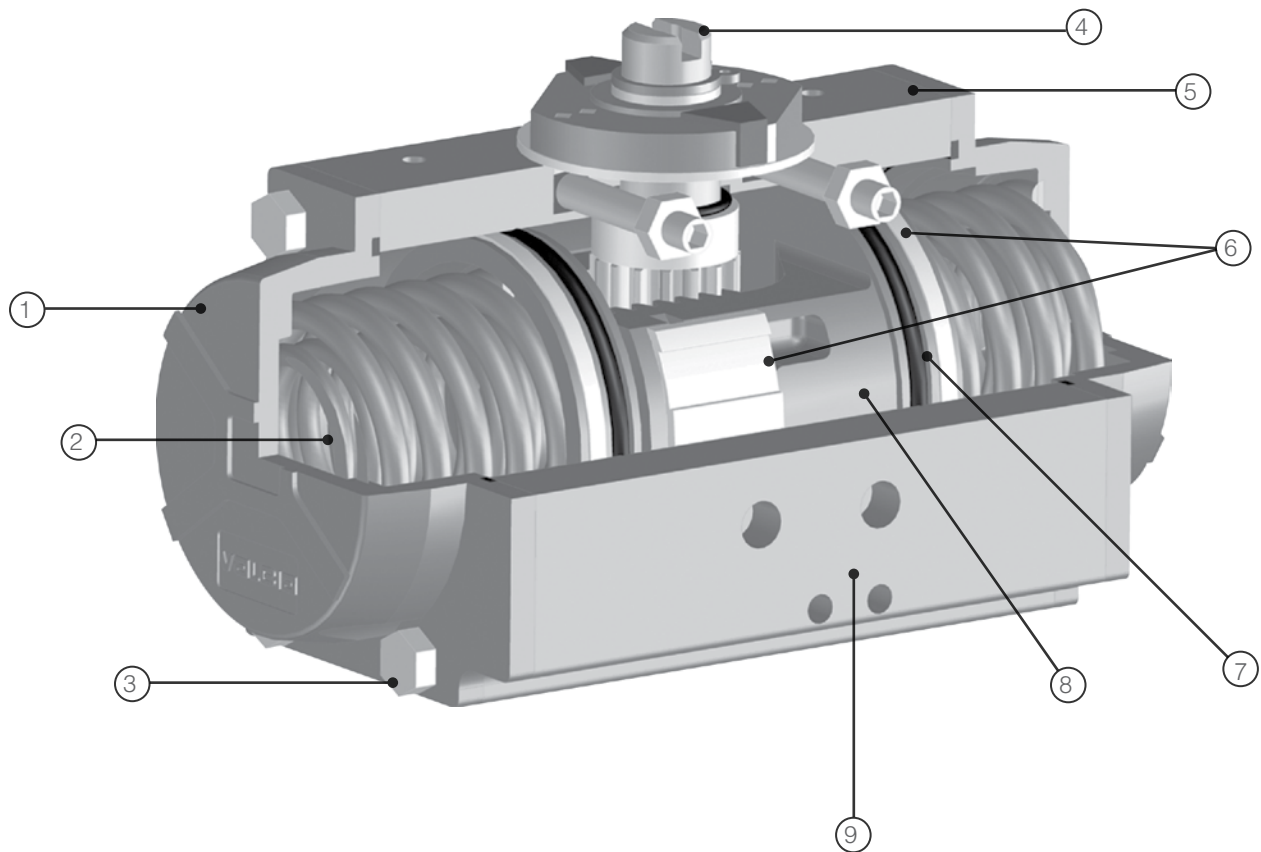

1 Die cast aluminium end caps

- Standard polyester powder coated
- Upon request – nickel plated for corrosive environments

2 Spring sets

- Standard treatment phosphated
- High resistance and reliability
- Spring sets to suit different air pressure/torque requirements

3 End cap screw

- Stainless steel as standard

4 Pinon made in steel

- Nickel-plated for standard version against internal and external corrosion
- Stainless steel for corrosive environments
- Anti-blowout design standard

5 Body manufactured from extruded aluminum UNI 6060

- Hard-coated anodized as standard finish 45-50 (micron)
- High corrosion resistance
- Special finishes epoxy-coated
- Bore finished to high standard to ensure low friction and long life

6 Piston guides in POM

- Large contact area
- Low friction for self-lubricating material
- Long life

7 Seals

- NBR standard version -4°F to 185°F (-20°C to 85°C)
- Viton high temperature version -4°F to 302°F (-20°C to 150°C)
- HNBR low temperature version -40°F to 185°F (-40°C to +85°C)

8 Pistons made from die cast aluminum

- Chemical nickel plating upon request

9 Extended connection

- Top of pinon NAMUR norm
- Solenoid valve connection NAMUR norm & NPT
- Bottom of pinon ISO 5211-DIN 3337

Rotation (Viewed from top)

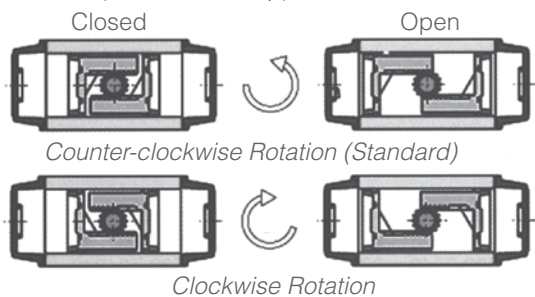

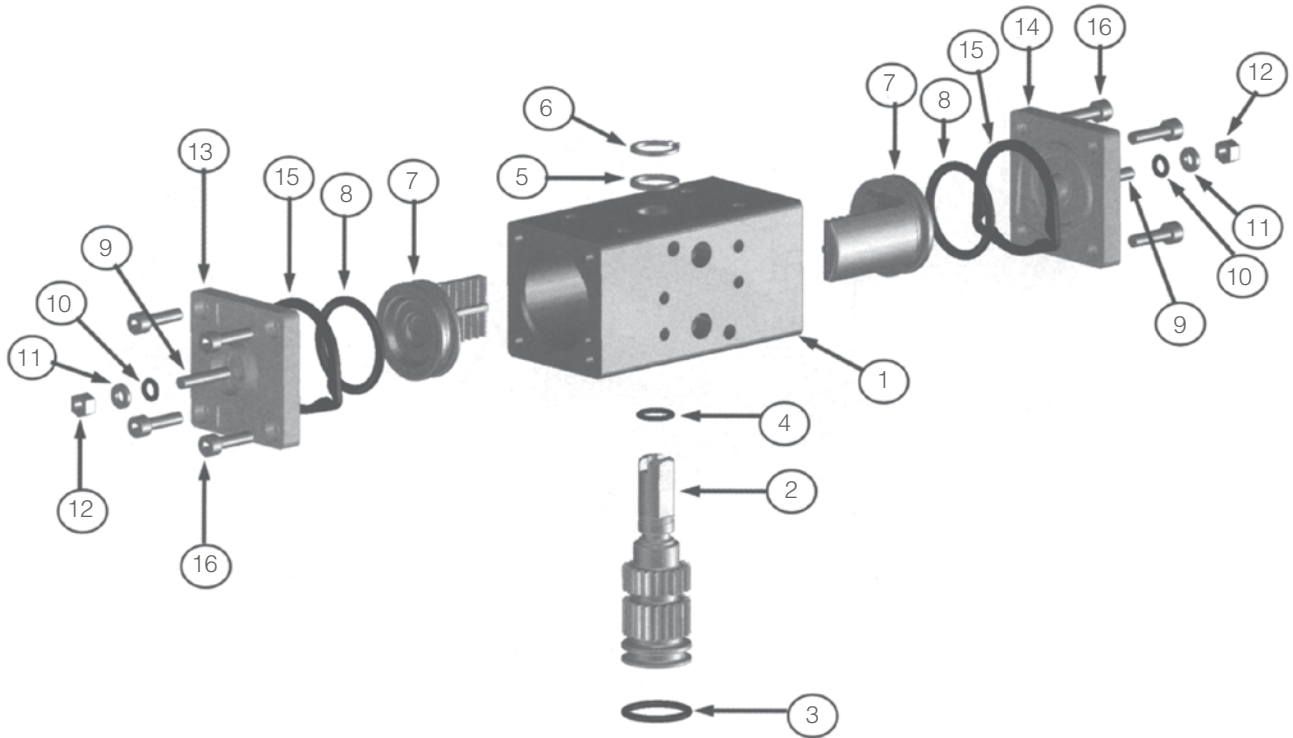

Actuator Parts — UTOA					
Item	Repair Kit	Description	Material	Treatment	Quantity DA
1		Body	Extruded Aluminum	Hard Anodized	1
2		Anti-blowout Pinion	Steel	Nickel Plated	1
*3	R	Lower Pinion O-Ring	NBR		1
*4	R	Top Pinion O-Ring	NBR		1
*5	R	Spacer Ring	(POM) PolyOxyMethylene		1
6	R	Pinion Snap Ring	Steel	Nickel Plated	1
7		Piston	Die Cast Aluminum		2
*8	R	Piston O-Ring	NBR		2
9		Stop Bolt	Stainless Steel		2
*10	R	Stop Bolt O-Ring	NBR		2
11		Washer	Stainless Steel		2
12		Stop Bolt Retaining Nut	Stainless Steel		2
13		Left End Cap	Die Cast Aluminium	Painted	1
14		Right End Cap	Die Cast Aluminium	Painted	1
15	R	End Cap Gaskets	NBR		2
16		End Cap Fixing Screw	Stainless Steel		8

* Parts subject to wear

Note: For high temperature option, Viton replaces NBR, and high temperature grease is used.

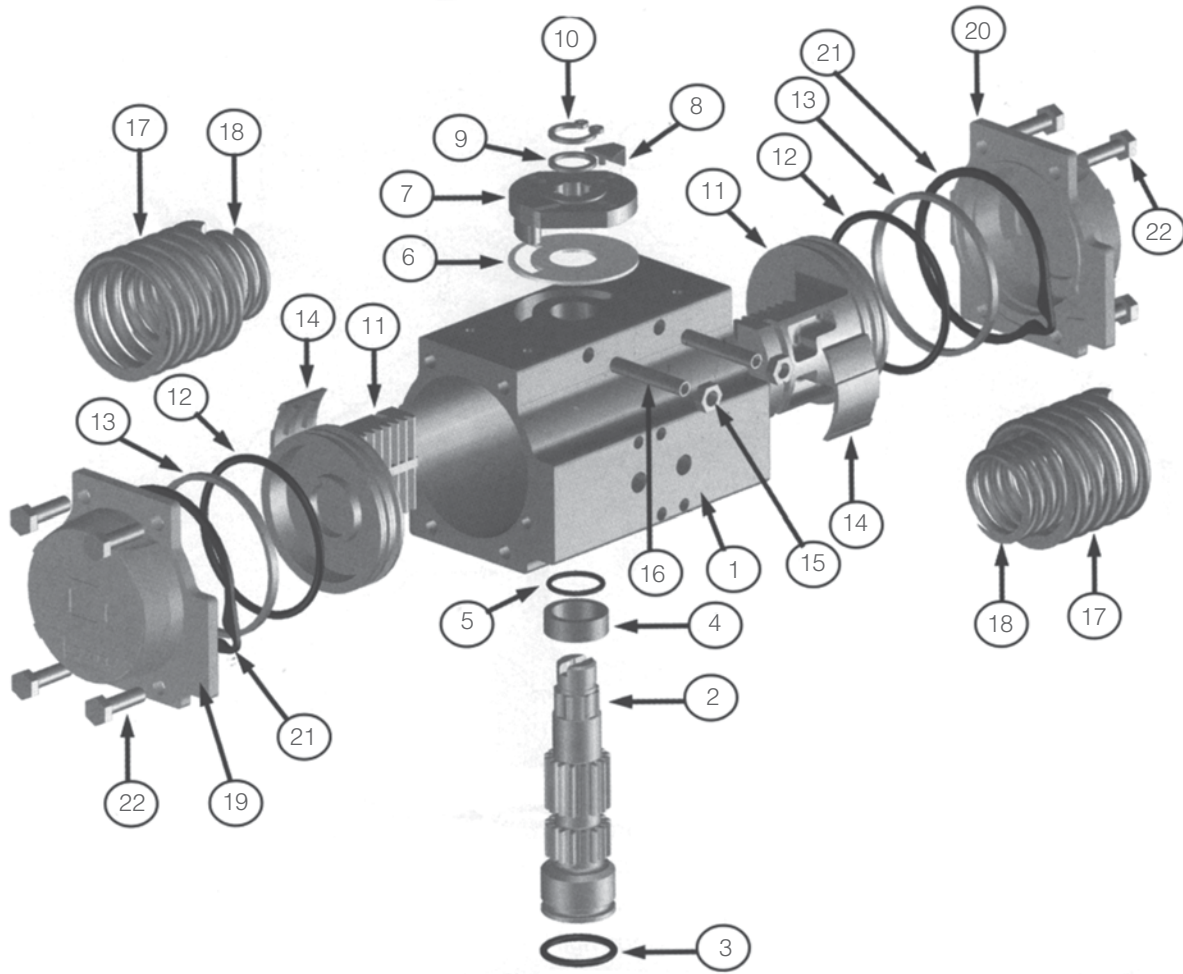

Actuator Parts — UT0 – UT4.5					
Item	Description	Material	Treatment	Quantity DA	Quantity SR
1	Body	Extruded Aluminum	Hard Anodized	1	1
2	Anti-blowout Pinion	Steel	Nickel Plated	1	1
*3	Lower Pinion O-Ring	NBR		1	1
*4	Pinion Spacer Ring	(POM) PolyOxyMethylene		1	1
*5	Top Pinion O-Ring	NBR		1	1
*6	Cam Spacer Ring	(POM) PolyOxyMethylene		1	1
7	Cam	Stainless Steel		1	1
8	Position Indicator	Nylon		2	2
9	Pinion Washer	Stainless Steel		1	1
10	Pinion Snap Ring	Steel	Nickel Plated	1	1
11	Piston	Die Cast Aluminum		2	2
*12	Piston O-Ring	NBR		2	2
*13	Anti-friction Ring	(POM) PolyOxyMethylene		2	2
*14	Piston Thrust Block	(POM) PolyOxyMethylene		2	2
15	Stop Bolt Retaining Nut	Stainless Steel		2	2
16	Stop Bolt	Stainless Steel		2	2
17	External Spring	Steel	Zinc-phosphate	0	See Spring Chart, pg 6
18	Internal Spring	Steel	Zinc-phosphate	0	See Spring Chart, pg 6
19	Left End Cap	Die Cast Aluminum	Painted	1	1
20	Right End Cap	Die Cast Aluminum	Painted	1	1
21	End Cap Gaskets	NBR		2	2
22	End Cap Fixing Screw	Stainless Steel		8	8

* Parts subject to wear

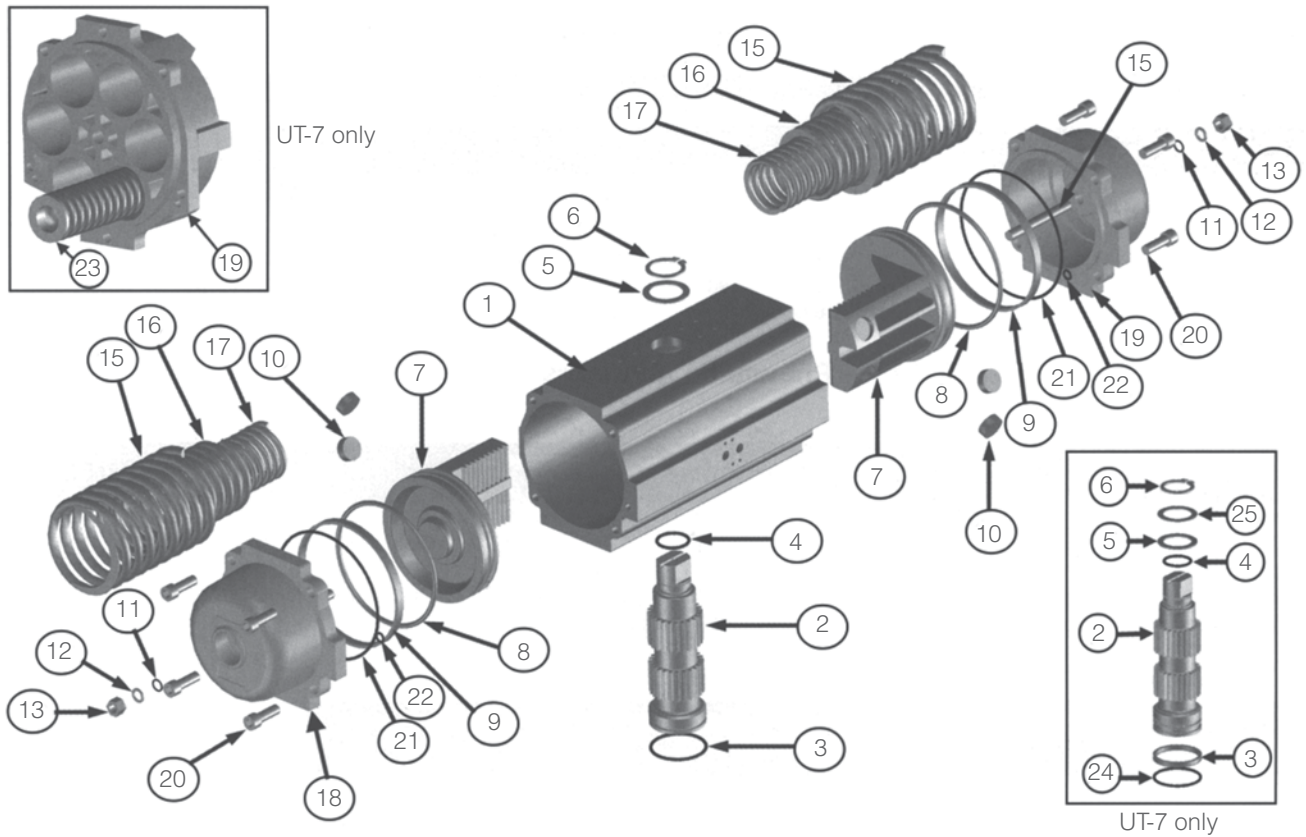

Actuator Parts — UT5, UT6, UT7, UT0A						
Item	Repair Kit	Description	Material	Treatment	Quantity DA	Quantity SR
1		Body	Extruded Aluminum	Hard Anodized	1	1
2		Anti-blowout Pinion	Steel	Nickel Plated	1	1
*3	R	Lower Pinion O-Ring	NBR		1	1
*4	R	Top Pinion O-Ring	NBR		1	1
*5	R	Pinion Spacer Rang	(POM) PolyOxyMethylene		1	1
6	R	Pinion Snap Ring	Steel	Nickel Plated	1	1
7		Piston	Die Cast Aluminum		2	2
*8	R	Piston O-Ring	NBR		2	2
*9	R	Anti-friction Ring	PTFE 15% Graphite		2	2
*10	R	Piston Thrust Block	(POM) PolyOxyMethylene		4 <u>6</u> ***	4 <u>6</u> ***
*11	R	Stop Bolt O-Ring	NBR		2	2
12		Washer	Stainless Steel		2	2
13		Stop Bolt Retaining Nut	Stainless Steel		2	2
14		Stop Bolt	Stainless Steel		2	2
15		External Spring	Steel	Zinc-phosphate	0	See Spring Chart, pg 6
16		Central Spring	Steel	Zinc-phosphate	0	
17		Internal Spring	Steel	Zinc-phosphate	0	
18		Left End Cap	Die Cast Aluminum	Painted	1	1
19		Right End Cap	Die Cast Aluminum	Painted	1	1
20		End Cap Fixing Screw	Stainless Steel		8, <u>12</u> ***	8, <u>12</u> ***
21	R	End Cap O-Ring	NBR		2	2
22	R	Air Supply Hole O-Ring	NBR		2	2
23	†	Compressed Spring ***	Steel		0	See spring chart
*24	† R	Anti-friction Ring ***	PTFE 15% Graphite		1	1
25	† R	Pinion Washer ***	Stainless Steel		1	1

* Parts subject to wear
 † UT-7 only

*** 6 12 Valid for UT-7 only
 Note: for high temperature option, Viton replaces NBR and high temperature grease is used

Spring Chart for UT-0-SR thru UT-4.5SR			
Set No.	Norm Air Supply	External Spring	Internal Spring
1	40	1	1
2	50	2	0
3	60	1	2
4	70-80	2	1
5	90	2	2

Spring Chart for UT-5-SR thru UT-6-SR				
Set No.	Norm Air Supply	External Spring	Center Spring	Internal Spring
1	40	0	2	0
2	50	2	0	0
3	60	1	2	0
4	70	2	0	2
5	80	2	2	0
6	90	2	2	2

Spring Chart for UT-7-SR R		
Set No.	Norm Air Supply	Quantity of Springs for Each Side
1	30	2/3
2	40	3/3
3	50	3/4
4	60	4/4
5	70	4/5
6	75	5/5
7	80	5/6
8	90	6/6

Cycle Time for UT Series Actuators													
Type	0A	0	1	2	2.5	3	3.5	4	4.5	5	6	7	
Double Act. CCW	0.03	0.03	0.06	0.12	0.20	0.30	0.53	0.83	0.98	1.15	1.74	4.50	
Double Act. CW	0.03	0.04	0.08	0.12	0.19	0.27	0.47	0.66	0.93	1.10	1.70	4.50	
Spr. Return, CCW	—	0.09	0.14	0.22	0.31	0.44	0.83	1.08	1.27	1.75	2.38	4.50	
Spr. Return, CW	—	0.09	0.14	0.22	0.31	0.46	0.78	0.90	0.97	1.34	2.19	6.20	

Approximate time per stroke in seconds (one direction) at 80 psi supply pressure without valve

Air Consumption (Volume, Cubic Inches)													
Rotation Direction (DA or SR)	0A	0	1	2	2.5	3	3.5	4	4.5	5	6	7	
CCW (DA & SR)	2.4	6.1	11.6	22.0	31.1	48.2	78.7	99.5	138	220	348	915	
CW (DA)	1.8	7.9	14.0	26.8	39.1	61.0	104	135	193	290	600	1086	
CW (SR)	—	6.7	11.6	22.0	32.3	48.8	84.2	109	146	215	463	946	

$$\text{Air Consumption, Standard cubic inch per stroke} = \frac{(\text{Gage Pressure} + \text{Atmosphere Pressure}) \times \text{Volume, in}^3}{\text{Atmosphere Pressure}}$$

Weight (lbs)													
Type	0A	0	1	2	2.5	3	3.5	4	4.5	5	6	7	
Double Acting	1.1	2.3	3.3	5.6	7.2	11.0	17.8	22.1	34	43	71	154	
Spring Return	—	2.6	4.0	6.9	9.4	14.4	23.9	26.8	45	65	111	193	

Air Supply Pressure

Maximum Pressure: 116 psi (8 bar)

Temperature Range: See Page 2

Position Adjustment

- UT-0A – single adjustable open stop (+/- 5° in CCW direction/ fixed close stop only)
- UT-0 thru UT4.5 – dual adjustable open-close stops standard (+/- 5° in CW and CCW directions)
- UT5 thru UT7 – single adjustable open stop (+/- in CCW direction)/fixed close stop standard; dual adjustable open-close stops optional (+/- 5° in CW and CCW directions)

External Connections: See Page 2

Rotation: See Page 2

Lubrication:

Lubricated: for actuator life (1,000,000 cycles under normal working conditions)

Actuator Selection

Valve Torque

Determine the maximum valve torque from the valve torque chart for the seat material used. This is normally the breakaway torque after the valve has been stationary for the longest period of time. Apply an appropriate service factor to the valve torque to determine the required torque: 20% for normal operation; 50% for dry, dirty or infrequent operation; and 100% for emergency shutoff or throttling control valves

Double Acting Selection

Refer to Double Acting Torque Chart. Read down the applicable Air column to the first torque that exceeds the required torque, then left to the actuator size.

Spring Return Selection

Refer to the Spring Return Torque Chart. Read down the Spring End column to the first torque that exceeds the required torque, then right to the applicable Air End column. If the Air End torque also exceeds the required torque, read left to the actuator size and spring set. If not, move down the chart one actuator size at a time and repeat, until both torques exceed the required torque.

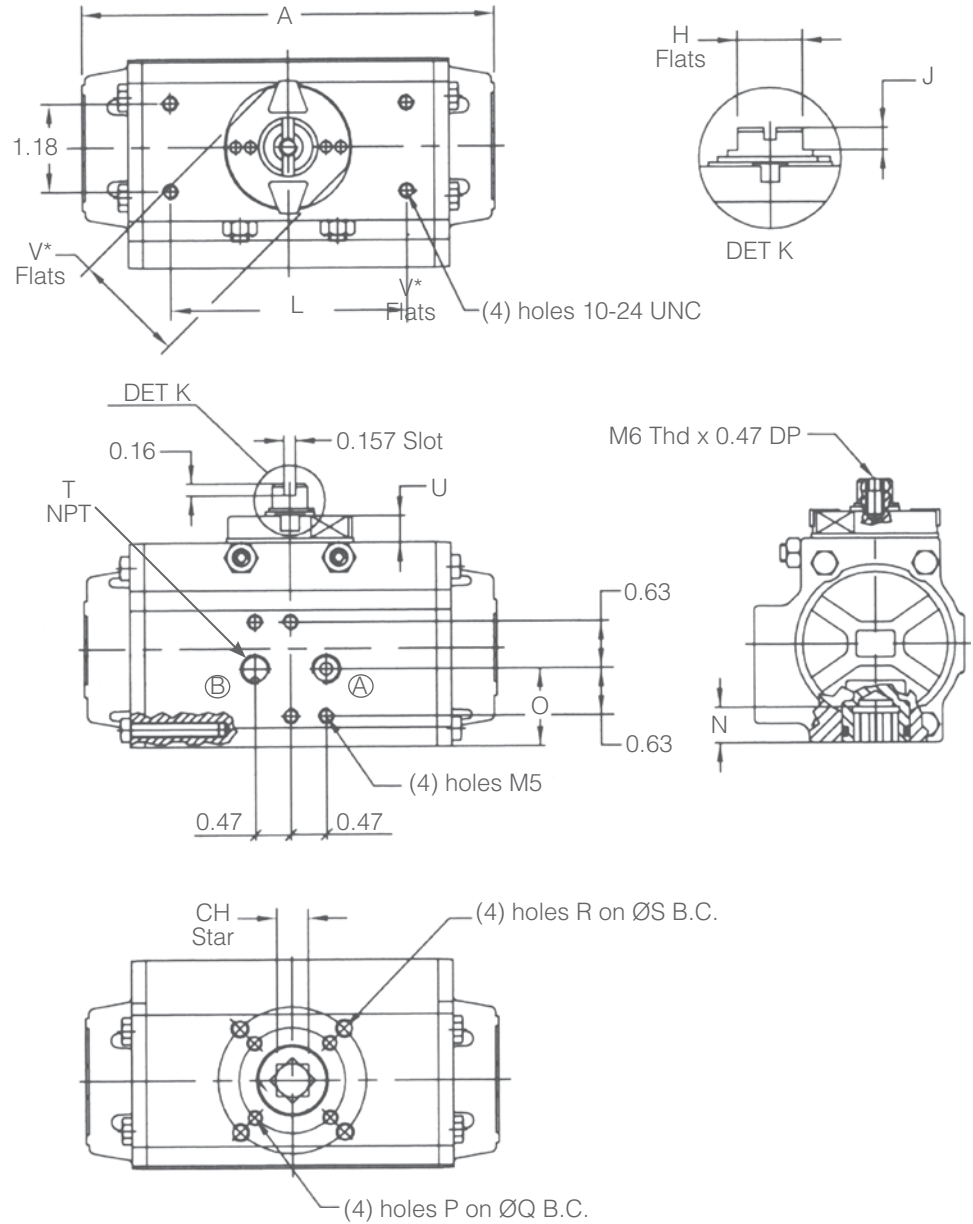

Ports:
 A CCW Rotation
 B CW Rotation

ART0657

Dimensions, Inches																							
Model	UT Series (UT0 – UT4.5)																						
	Inches	Bore	Drilling ISO 5211	CH	A	B	C	D	E	F	G	H	I	ØK	L	N	O	P	Q	R	ØS	T NPT	U
UT0	52	F03-F05	0.433	5.5	2.8	1.2	1.6	2.7	0.79	3.5	0.35	1.73	0.47	3.15	0.47	1.04	10-24 x0.29	1.42	1/4-20 x0.35	1.97	1/8	0.32	1.49
UT1	63	F05-F07	0.551	6.4	3.2	1.4	1.8	3.2	0.79	4.0	0.43	1.97	0.59	3.15	0.63	1.08	1/4-20 x0.31	1.97	5/16-18 x0.47	2.76	1/8	0.32	1.61
UT2	75	F05-F7	0.669	8.2	3.7	1.7	2.1	3.8	0.79	4.6	0.51	2.48	0.75	3.15	0.75	1.38	1/4-20 x0.31	1.97	5/16-18 x0.47	2.76	1/8	0.35	1.97
UT2.5	85	F05-F07	0.669	9.4	4.2	1.9	2.3	4.3	0.79	5.1	0.59	2.48	0.87	3.15	0.75	1.65	1/4-20 x0.31	1.97	5/16-18 x0.47	2.76	1/8	0.35	1.97
UT3	100	F07-F10	0.669	10.7	4.9	2.2	2.7	4.8	0.79	5.6	0.59	2.48	0.87	3.15	0.81	1.97	5/16-18 x0.47	2.76	3/8-16 x0.55	4.02	1/4	0.35	1.97
UT3.5	115	F07-F10	0.866	12.9	5.4	2.5	2.9	5.6	1.18	6.8	0.87	3.39	1.26	5.12	0.94	1.97	5/16-18 x0.47	2.76	3/8-16 x0.55	4.02	1/4	0.57	—
UT4	125	F07-F10	0.866	14.4	5.9	2.7	3.2	6.0	1.18	7.2	0.87	3.39	1.26	5.12	0.94	2.40	5/16-18 x0.47	2.76	3/8-16 x0.55	4.02	1/4	0.57	—
UT4.5	140	F10-F12	1.063	16.9	6.4	3.0	3.4	6.9	1.18	8.1	0.95	3.46	1.38	5.12	1.14	2.80	3/8-16 x0.59	4.02	1/2-13 x0.71	4.92	1/4	0.57	—

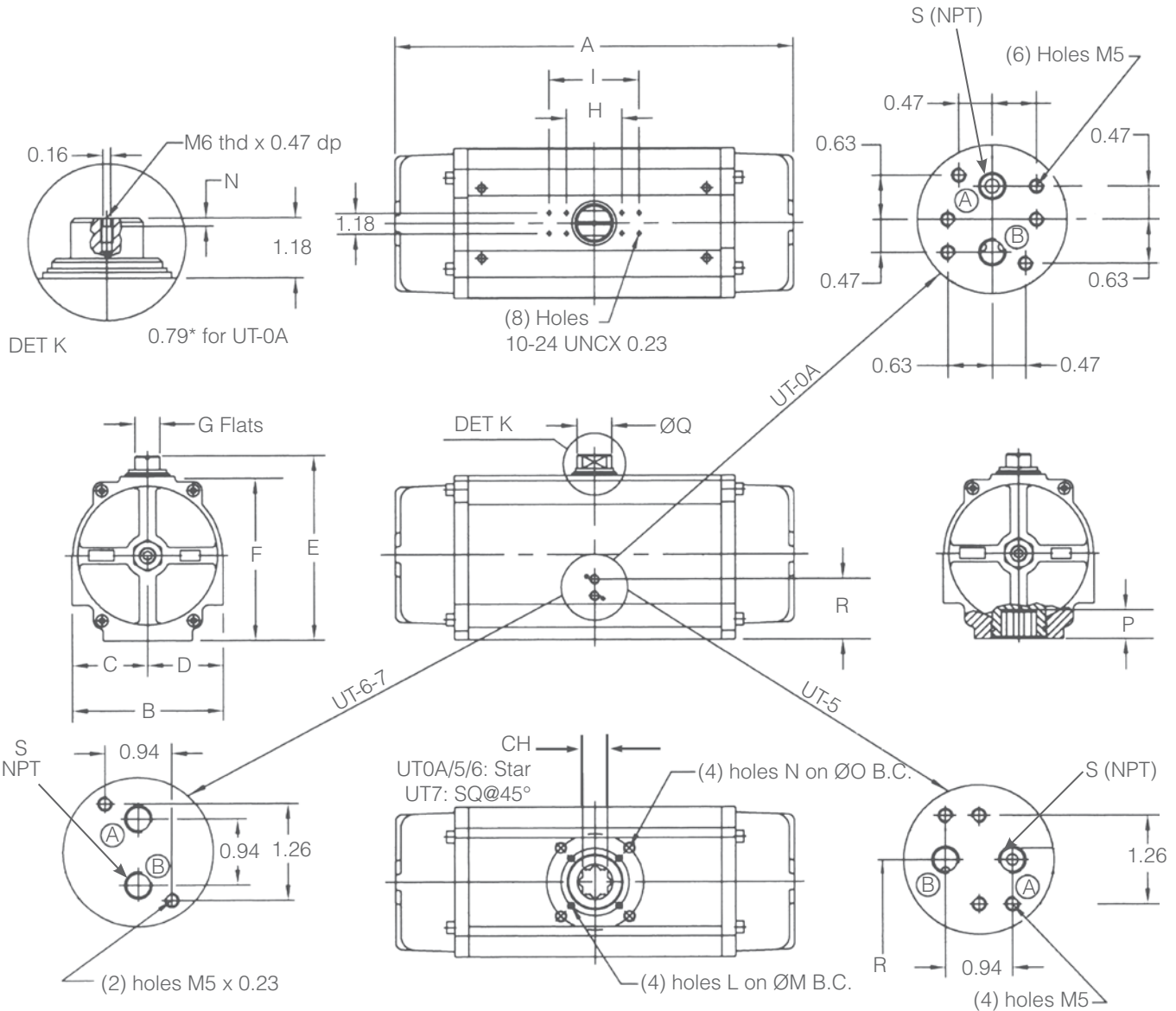

Ports:

A CCW Rotation

B CW Rotation

ART0656

Dimensions, Inches																				
Model	UT Series (UT0A & UT5 – UT7)																			
	Bore	Drilling ISO 5211	CH	A	B	C	D	E	F	G	H	I	L	M	N	O	P	Q	R	S NPT
UT0A*	32	F03	0.354	4.3	1.8	0.9	0.9	2.56	1.77	0.39	1.97	—	—	—	10-24 x0.29	1.42	0.47	0.46	—	1/8
UT5	160	F10-F12	1.063	20.6	7.4	3.4	3.9	8.58	7.4	1.18	3.15	5.12	3/8-16 x0.59	4.02	1/2-13 x0.71	4.92	1.26	1.38	3.21	1/4
UT6*	200	F14	1.417	22.6	8.6	4.3	4.3	10.59	9.41	1.42	3.15	5.12	—	—	5/8-11 x0.98	5.51	1.54	1.97	3.46	1/4
UT7*	270	F16	1.811**	26.5	11.4	5.7	5.7	14.21	13.03	1.42	3.15	5.12	—	—	3/4-10 x1.18	6.50	2.05	1.97	4.76	1/4

* UT-0A, UT-6 and UT-7 require NAMUR based adaptor 26-0002 for mounting NAMUR (direct mount) solenoid valves

** Square female connection at 45° only

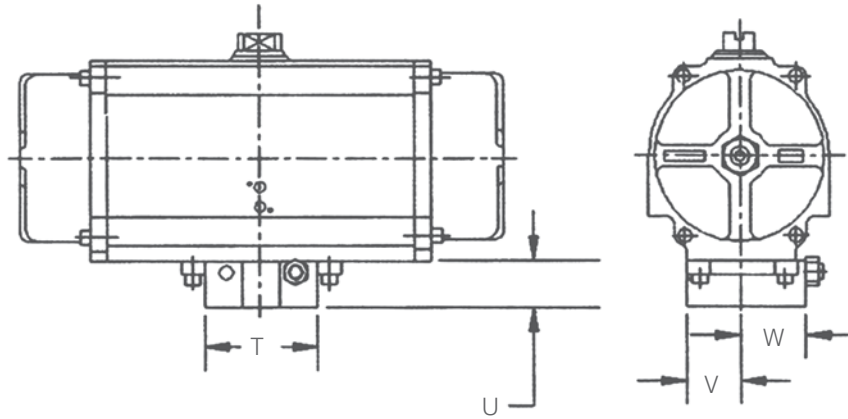

ART0790

Dimensions, Inches (UT 5/6/7 with Optional Dual Limit Stops)				
Model Inches	T	U	V	W
UT5	6.29	1.77	2.20	2.50
UT6	7.48	2.03	2.52	3.11
UT7	9.05	2.68	3.11	4.37

Torque Characteristics

Double Acting

IN AIR (A)

IN AIR (B)

Start → End
Close → Open

The Double Acting Actuator has a constant output torque travel from start to end, clockwise or counter-clockwise rotation

Spring Return

(B) OUT AIR

(A) IN AIR

Direct Rotation Air Start

Air End

Direct Rotation

SPR Start

SPR End

The torque of the Spring Return Actuator is not constant but decreasing. This is due to spring compression during air cycle and spring uncoiling during spring cycle of actuation.

Torque Outputs																	
Model		Spring Torque (in-lbs)		Air Supply Pressure (psig)													
Size	Spring Set			40		50		60		70		80		90		100	
				Air Torque (in-lbs)													
		Start	End	Start	End	Start	End	Start	End	Start	End	Start	End	Start	End	Start	End
UT-0	01	44	32	48	23	72	47	95	70	—	—	—	—	—	—	—	—
	02	59	42	—	—	61	31	84	54	108	77	—	—	—	—	—	—
	03	66	46	—	—	—	—	80	47	104	70	127	94	150	117	—	—
	04	82	57	—	—	—	—	70	31	93	55	116	78	140	101	163	125
	05	105	72	—	—	—	—	—	—	78	32	101	55	125	78	148	102
UT-1	01	85	44	92	38	134	80	176	122	—	—	—	—	—	—	—	—
	02	109	58	—	—	120	56	162	98	204	140	—	—	—	—	—	—
	03	128	71	—	—	—	—	149	79	191	121	233	162	275	204	—	—
	04	152	85	—	—	—	—	136	54	177	96	219	138	261	180	303	222
	05	196	111	—	—	—	—	—	—	151	53	193	95	235	136	276	178
UT-2	01	172	89	168	63	244	138	319	214	—	—	—	—	—	—	—	—
	02	226	118	—	—	215	85	291	160	366	235	—	—	—	—	—	—
	03	249	133	—	—	—	—	275	137	351	212	426	288	502	363	—	—
	04	303	162	—	—	—	—	247	83	322	158	398	234	473	309	549	385
	05	380	205	—	—	—	—	—	—	279	81	354	157	430	232	505	303
UT-2.5	01	242	143	238	109	349	219	460	330	—	—	—	—	—	—	—	—
	02	298	176	—	—	316	163	427	274	537	384	—	—	—	—	—	—
	03	361	215	—	—	—	—	387	211	498	322	609	432	720	543	—	—
	04	417	248	—	—	—	—	354	155	465	265	576	376	687	487	797	633
	05	536	321	—	—	—	—	—	—	392	146	503	257	614	368	725	478
UT-3	01	395	218	384	154	556	326	728	499	—	—	—	—	—	—	—	—
	02	521	288	—	—	485	199	658	372	830	544	—	—	—	—	—	—
	03	564	318	—	—	—	—	628	329	801	502	973	674	1146	847	—	—
	04	691	389	—	—	—	—	558	203	730	375	903	548	1075	720	1248	893
	05	860	489	—	—	—	—	—	—	630	206	802	378	975	551	1147	723
UT-3.5	01	658	363	650	270	935	555	1220	840	—	—	—	—	—	—	—	—
	02	835	449	—	—	848	378	1133	663	1419	949	—	—	—	—	—	—
	03	957	538	—	—	—	—	1044	541	1329	827	1615	1112	1900	1397	—	—
	04	1133	625	—	—	—	—	958	365	1243	650	1528	935	1813	1220	2098	1505
	05	1432	800	—	—	—	—	—	—	1067	352	1352	637	1638	922	1923	1207
UT-4	01	877	470	850	328	1224	703	1599	1077	—	—	—	—	—	—	—	—
	02	1040	560	—	—	1135	539	1509	914	1883	1288	—	—	—	—	—	—
	03	1313	718	—	—	—	—	1351	640	1725	1015	2099	1389	2474	1763	—	—
	04	1477	808	—	—	—	—	1261	477	1636	851	2010	1226	2389	1600	2758	1974
	05	1913	1055	—	—	—	—	—	—	1388	415	1762	789	2136	1164	2511	1538
UT-4.5	01	1345	726	1241	506	1742	1007	—	—	—	—	—	—	—	—	—	—
	02	1522	814	—	—	1644	821	2142	1322	2645	1822	—	—	—	—	—	—
	03	1956	1036	—	—	—	—	1915	861	2415	1362	2916	1862	3416	2363	—	—
	04	2124	1133	—	—	—	—	1807	665	2310	1168	2813	1671	3316	2174	3819	2677
	05	2726	1452	—	—	—	—	—	—	1981	516	2482	1018	2982	1520	3483	2022

Torque Outputs																	
Model		Spring Torque (in-lbs)		Air Supply Pressure (psig)													
Size	Spring Set			40		50		60		70		80		90		100	
		Air Torque (in-lbs)															
		Start	End	Start	End	Start	End	Start	End	Start	End	Start	End	Start	End	Start	End
UT-5	01	1345	885	1921	1390	2644	2140	—	—	—	—	—	—	—	—	—	—
	02	1991	1301	—	—	2228	1503	2952	2217	—	—	—	—	—	—	—	—
	03	2336	1531	—	—	1980	1131	2713	1854	3419	2569	—	—	—	—	—	—
	04	2841	1170	—	—	—	—	2447	1350	3162	2074	3886	2779	—	—	—	—
	05	3327	2230	—	—	—	—	—	—	2737	1507	3452	2240	4175	2963	—	—
	06	4186	2655	—	—	—	—	—	—	—	—	2983	1443	3715	2167	4421	2828
UT-6	01	2168	1540	3718	2904	5069	4317	—	—	—	—	—	—	—	—	—	—
	02	3150	2186	—	—	4413	3308	5770	4681	—	—	—	—	—	—	—	—
	03	3752	2637	—	—	3936	2591	5304	4035	6639	5400	—	—	—	—	—	—
	04	4699	3124	—	—	—	—	4788	3080	6126	4445	7486	5795	—	—	—	—
	05	5327	3726	—	—	—	—	—	—	5443	3613	6822	5008	8182	6385	—	—
	06	6867	4664	—	—	—	—	—	—	—	—	5893	3539	7288	4925	8591	6175
UT-7	01	6973	4469	8574	6017	11883	9317	15309	12743	—	—	—	—	—	—	—	—
	02	8372	5363	7619	4548	10928	7857	14353	11283	—	—	—	—	—	—	—	—
	03	9761	6257	6672	3088	9972	6388	13398	9814	16824	13240	—	—	—	—	—	—
	04	11159	7150	5716	1619	9016	4928	12442	8353	15877	11779	19177	15080	—	—	—	—
	05	12549	8044	—	—	8069	3459	11495	6884	14921	10310	18221	13619	21530	16920	—	—
	06	13947	8938	—	—	—	—	10539	5415	13965	8850	17274	12150	20574	15459	—	—
	07	15336	9832	—	—	—	—	9584	3955	13009	7381	16319	10681	19619	13990	23053	17416
	08	16735	10735	—	—	—	—	8637	2486	12063	5912	15363	9221	18672	12521	22098	15947

Torque Outputs – Double Acting Actuators (in-lbs) Air Supply Pressure (psig)								
Model	40	50	60	70	80	90	100	115
UT-0A	34	43	55	64	71	82	87	101
UT-0	93	117	140	162	186	210	233	268
UT-1	165	206	247	289	330	371	412	474
UT-2	297	371	446	519	594	668	742	854
UT-2.5	423	528	635	740	846	952	1057	1217
UT-3	667	834	1000	1167	1334	1501	1668	1918
UT-3.5	1099	1373	1648	1923	2197	2472	2746	3158
UT-4	1424	1780	2136	2491	2848	3204	3560	4093
UT-4.5	2001	2503	3005	3506	4008	4510	5012	5765
UT-5	2930	3662	4394	5127	5859	6591	7324	8422
UT-6	5488	6866	8239	9612	10981	12359	13732	15792
UT-7	12734	15919	19097	22284	25469	28654	31832	36611

How to Order					
Actuator Series	Size	Type	Rotation	Air Supply to Actuator	Options
UT	0A = 32mm bore	SR = Spring Return (UT-0-7)	CCW = Counter-clockwise Rotation (Standard)	40 = 40 psi	— = None (Standard)
	0 = 52mm bore	SD = Spring Return with Optional Dual Adjustable Stops (UT5-7)	CW = Clockwise Rotation	50 = 50 psi	P = Polyester Coating
	1 = 63mm bore	DA = Double Acting (UT0A-7)		60 = 60 psi	V = Viton Seals
	2 = 75mm bore	DD = Double Acting with Optional Dual Adjustable Stops (UT5-7)		70 = 70 psi	
	2.5 = 85mm bore			80 = 80 psi	
	3 = 100mm bore			90 = 90 psi	
	3.5 = 115mm bore			100 = 100 psi	
	4 = 125mm bore			115 = 115 psi	
	4.5 = 140mm bore				
	5 = 160mm bore				
	6 = 200mm bore				
	7 = 270mm bore				

Sample Ordering Schematic

UT	1	SR	CCW	80	—
----	---	----	-----	----	---