

(NL) Vibrator motoren

>> Maatschets

(D) Vibrationsmotoren

>> Maß-Skizze

(GB) Vibrator motors

>> Dimensions

50 Hz

RS-Type



FRIEDRICH
SCHWINGTECHNIK GmbH



FRIEDRICH



Vimarc®

» Maatschets | Maße | Dimensions

4-polige Vibratormotoren (1460 min⁻¹) | 4-polige Vibrationsmotoren (1460 min⁻¹) | 4 pole Vibrator Motors (1460 min⁻¹)

Arbeitsmoment Arbeitsmoment Working moment kgcm	Centrifugale Kracht Fliehkraft Centrifugal force N	Vermogen Leistungsaufnahme Power consumption kW	Stromstärke bij 400 V Nennstrom bei 400 V Nominal current at 400 V A	Oprengsfactor Leistungsfaktor Power factor cos φ	Aanloop-/Nominiaalstroom Anzugsstrom/Nennstrom Starting current ratio IA/IN	Type	Gatabeelding nr. Lochbild Nr. Motor base No.	Maatschets Maße Dimensions mm																Gewicht Gewicht Weight kg	Kabel Kable Cable mm	Schroeven Schrauben Hexagon screw 8.8
								a	b	c	d	e	f	g	h	j	k	m	n							
60	7012	0,70	1,66	0,84	4,6	BX 60-4 RS		384	192	140	170	212	235	18	114	258	20	67,5	228	54	4x1,5	4xM16				
90	10523	0,70	1,66	0,84	4,6	BX 90-4 RS		416	192	140	170	212	235	18	114	258	20	67,5	228	58	4x1,5	4xM16				
150	17534	0,70	1,66	0,84	4,6	BX 150-4 RS		496	192	140	170	212	235	18	114	258	20	67,5	228	72	4x1,5	4xM16				
200	23379	0,70	1,66	0,84	4,6	BX 201-4 RS		570	192	140	170	212	235	18	114	258	20	67,5	228	77	4x1,5	4xM16				

6-polige Vibratormotoren (980 min⁻¹) | 6-polige Vibrationsmotoren (980 min⁻¹) | 6 pole Vibrator Motors (980 min⁻¹)

kgcm	N	kW	A	cos φ	IA/IN	Type	a	b	c	d	e	f	g	h	j	k	m	n	kg	mm	8.8
40	2108	0,45	1,40	0,82	2,5	BX 40-6 RS	340	192	140	170	212	235	18	114	258	20	67,5	228	52	4x1,5	4xM16
60	3158	0,45	1,40	0,82	2,5	BX 60-6 RS	384	192	140	170	212	235	18	114	258	20	67,5	228	54	4x1,5	4xM16
90	4737	0,45	1,40	0,82	2,5	BX 90-6 RS	416	192	140	170	212	235	18	114	258	20	67,5	228	58	4x1,5	4xM16
150	7894	0,45	1,40	0,82	2,5	BX 150-6 RS	496	192	140	170	212	235	18	114	258	20	67,5	228	68	4x1,5	4xM16
200	10532	0,45	1,40	0,82	2,5	BX 200-6 RS	570	192	140	170	212	235	18	114	258	20	67,5	228	77	4x1,5	4xM16

8-polige Vibratormotoren (740 min⁻¹) | 8-polige Vibrationsmotoren (740 min⁻¹) | 8 pole Vibrator Motors (740 min⁻¹)

kgcm	N	kW	A	cos φ	IA/IN	Type	a	b	c	d	e	f	g	h	j	k	m	n	kg	mm	8.8
40	1206	0,40	1,52	0,65	2,6	BX 40-8 RS	340	192	140	170	212	235	18	114	258	20	67,5	228	52	4x1,5	4xM16
60	1804	0,40	1,52	0,65	2,6	BX 60-8 RS	384	192	140	170	212	235	18	114	258	20	67,5	228	54	4x1,5	4xM16
90	2707	0,40	1,52	0,65	2,6	BX 90-8 RS	416	192	140	170	212	235	18	114	258	20	67,5	228	58	4x1,5	4xM16
150	4501	0,40	1,52	0,65	2,6	BX 150-8 RS	496	192	140	170	212	235	18	114	258	20	67,5	228	68	4x1,5	4xM16
200	6002	0,40	1,52	0,65	2,6	BX 200-8 RS	570	192	140	170	212	235	18	114	258	20	67,5	228	77	4x1,5	4xM16
250	7502	0,40	1,52	0,65	2,6	BX 250-8 RS	660	192	140	170	212	235	18	114	258	20	67,5	228	79	4x1,5	4xM16

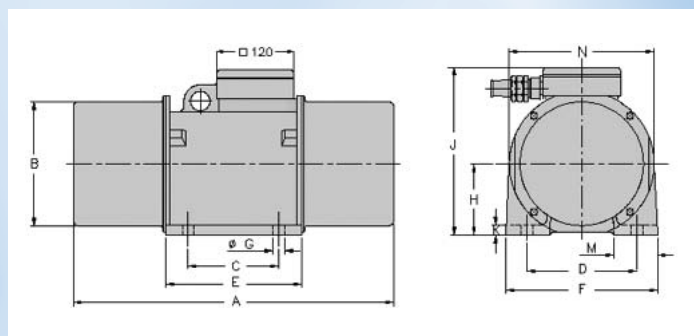

schematische presentatie - schematische Darstellung - schematic diagramm

FRIEDRICH Schwingtechnik GmbH

Postfach 101644 · 42760 Haan · Germany

Tel. +49 (0) 2129-37 90-0 · Fax +49 (0) 2129-37 90-37

www.friedrich-schwingtechnik.de · info@friedrich-schwingtechnik.de

Vimarc® Motor made by FRIEDRICH