

Industrial X-Ray

Cooler Manual XRC-3012-WA 3000 Watt water to air cooler



Document history

| Version | Date | Author | Amendment(s) | Status |
|----------------|-------------|---------------|------------------------|---------------|
| | 12/15/2008 | St. Haferl | | released |
| 1.0 | 07/22/2010 | M. Schmid | Layout / Structure | |
| | 07/22/2010 | St. Haferl | | released |
| 3.0 | 05/18/2011 | M. Schmid | Technical Details | |
| 4.0 | 10/30/2012 | R. Moser | Storage temperature | |
| 5.0 | 07/01/2013 | R. Moser | Update Chapter 3 | |
| 6.0 | 01/12/2015 | M. Schmid | New electrical drawing | |

Contents

| | | |
|-----|-------------------------------|----|
| 1 | Before you start | 4 |
| 2 | Product Description | 5 |
| 3 | Technical data | 6 |
| 3.1 | Physical dimensions | 6 |
| 3.2 | Performance data | 6 |
| 3.3 | Environmental specifications | 6 |
| 3.4 | Settings | 6 |
| 3.5 | Performance data and overview | 7 |
| 4 | Installation | 8 |
| 4.1 | Antifreeze concentration | 8 |
| 5 | Maintenance | 9 |
| 6 | Outline Drawing | 10 |
| 7 | Circuit Diagrams | 11 |
| 7.1 | Electrical diagram | 11 |
| 7.2 | Block diagram | 12 |
| 8 | Declaration of conformity | 13 |

1 Before you start

- Read the manual before setting into operation!
- Coolant: Water or water-glycol mixture (max. 1:1 water - glycol)
- Power supply 230 V 50/60 Hz!
- Run cooling unit always with correct coolant level otherwise cooling capacity is reduced!
- Clean filter regularly according to maintenance instructions, otherwise damage of pump may occur!
- Never operate cooling unit when ball cock is closed, otherwise damage of pump may occur!
- Only use cooling hoses with sufficient pressure resistance and with resistance to used coolant!
- Never operate damaged or leaking equipment!
- Before starting any service work disconnect the cooling unit from the mains.



2 Product Description

The cooling unit XRC-3012-WA is designed for the cooling of a water circuit. The coolant can be water or a mixture of water and antifreeze (water-glycol). Water circulates between the cooling unit and the heat source. The water is re-cooled by an air-cooled heat exchanger.

The system pressure is limited by a bypass valve.

Cooling hoses are connected to the cooling unit via Walther couplings.

Coolant inlet and outlet are marked with the labels:

Inlet: \downarrow \bigcirc ; **Outlet:** \uparrow \bigcirc

The water flow is monitored by an adjustable flow switch, the water temperature by a thermal switch. The contacts of the flow switch and the thermal switch are available as potential free signals on the internal terminal block: safety circuit. Both contacts are connected in series as one common error signal on the external Cannon connector. The contact is open when:

- The water flow is below the minimal set value
- The temperature of the coolant is higher than the maximal set value

3 Technical data

3.1 Physical dimensions

| | |
|-------------------|-------------------------|
| Length: | 483 mm |
| Width: | 406 mm |
| Height: | 481 mm |
| Weight: | 38.5 kg without filling |
| Coolant capacity: | 4.0 l |

3.2 Performance data

| | |
|-------------------------|---|
| Cooling capacity: | 3000 W ($\Delta T \leq 11$ K) |
| Flow rate: | ≥ 5.4 l / min at 4 bar |
| Mains voltage: | 230 V + 10% - 15% 48 - 62 Hz |
| Current consumption: | ≤ 2.6 A |
| Noise level: | 55 dB(A) (50 Hz) distance 1m in any direction 59 dB(A) (60 Hz) distance 1 m in any direction |
| Airflow at 50Hz (60Hz): | 2200 m ³ /h (2600 m ³ /h) |
| Safety class: | IP 33 |

3.3 Environmental specifications

| | |
|--------------------------|---|
| Operational temperature: | -10°C...+ 40°C (use antifreeze if ambient temperature is below 10°C) |
| Storage temperature: | -25°C...+ 70°C (store with antifreeze) |
| Air humidity: | 20%...90% non condensing |

3.4 Settings*

| | |
|---------------------------|-------------|
| Maximum forward pressure: | 6.7 bar |
| Flow switch open: | < 4.0 l/min |
| Flow switch close: | > 4.2 l/min |
| Thermal switch open: | > 50°C |
| Thermal switch close: | < 45°C |

* This setting value is optimized for our XRS modules

3.5 Performance data and overview

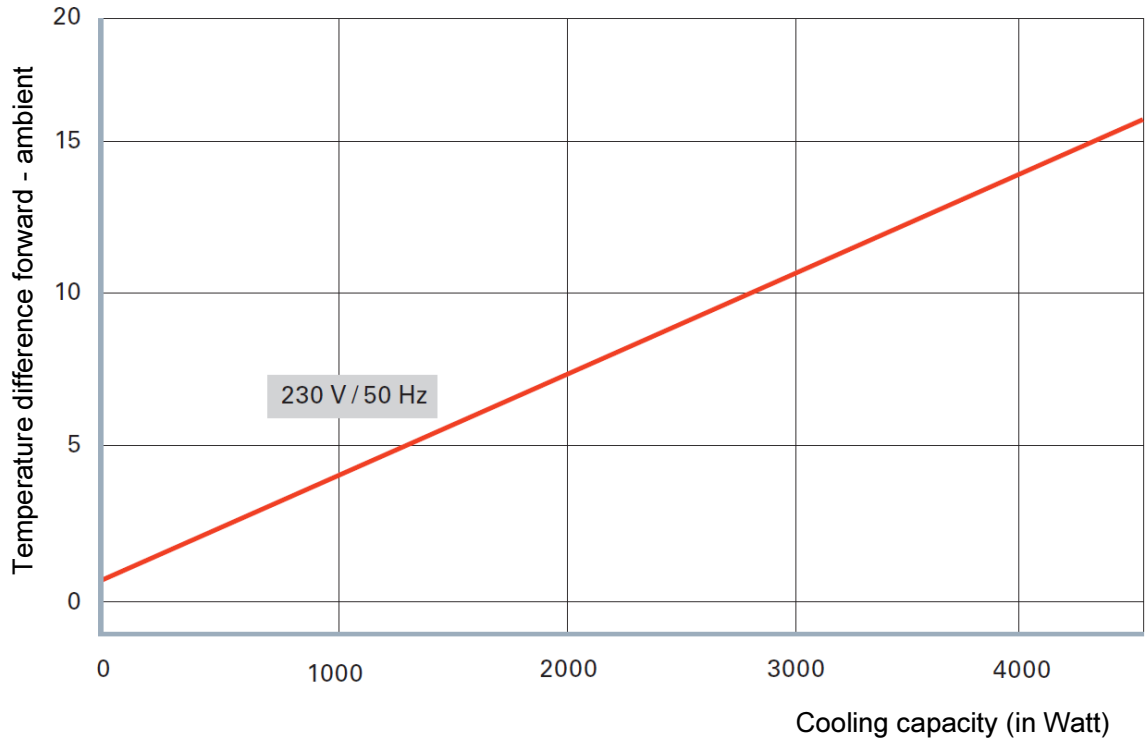

Overview

4 Installation

- The cooling unit must be positioned upright with sufficient clearance for air circulation (minimum clearance of 0,5m from the ventilation grid)
 - Connect the hoses on the cooling unit, respect the flow direction The maximum hose length is 20m provided that the cooler and the heat source are on the same level. If there is a height difference between both, it is shorter.
 - If the unit is exposed to ambient temperature below 0°C, prepare about 4.0 l of water mixed to Glycol according to the concentration table below
 - Open the lid and fill the cooling unit with the cooling mixture (about 4.0 l)
- Notice:
The liquid level must be always above the fins, otherwise the cooling capacity will be reduced !
- Switch on the unit (main switch on the control unit of the X-ray generator). Let the cooling unit run for about 10 minutes to deaerate the water circuit then check the level and refill if required.
 - Close the lid
 - Connect the electrical cable to the X-ray generator, at the rear of the power unit

4.1 Antifreeze concentration

It is essential that the correct antifreeze mix is added. The recommended antifreeze product is Ethylenglycol. See the table below for your guidance. Consult your antifreeze supplier for Ethylenglycol.

| Concentration by volume (%) | Approximate freezing point (°C) |
|-----------------------------|---------------------------------|
| 20 | -9 |
| 25 | -12 |
| 30 | -15 |
| 50 | -25 |

5 Maintenance

Regularly check the water level and refill if necessary.

Heat exchanger

In order to achieve the maximum cooling capacity, keep the heat exchanger of the cooling unit clean. Regularly check it and if necessary clean it:

Proceed as following:

- Disconnect cooling unit from the mains
- Remove complete cover
- Remove dust by forcing it out in the opposite direction from which it entered. If compressed air is available, direct the air against the inside of the heat exchanger
- Mount cover

Pump

About every 6 months check the filter of the pump for clean condition, if necessary more often. For this proceed as following:



Note: If the filter is not in clean condition damage of pump and motor may occur!

Proceed as following:

- Disconnect cooling unit from the mains
- Remove cover
- Close ball cock
- Unscrew filter cap (24 mm nut)



Note: Some water will run out of pump. Collect the water with suitable vessel!

- Clean filter if necessary or replace filter
- Insert filter and mount cap
- Open ball cock

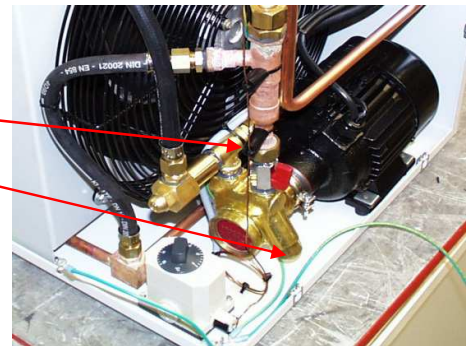

Attention: Never operate cooling unit when ball cock is closed, otherwise damage of pump may occur!

- Mount cover
- Run cooling unit to deaerate cooling circuit (see Setting to work)
- Check water level and refill if necessary

Placing out of operation/Service/Repair

- Disconnect cooling unit from the mains
- Remove hoses
- Remove cap and drain of coolant, collect with suitable vessel
- Mount cap

6 Outline Drawing

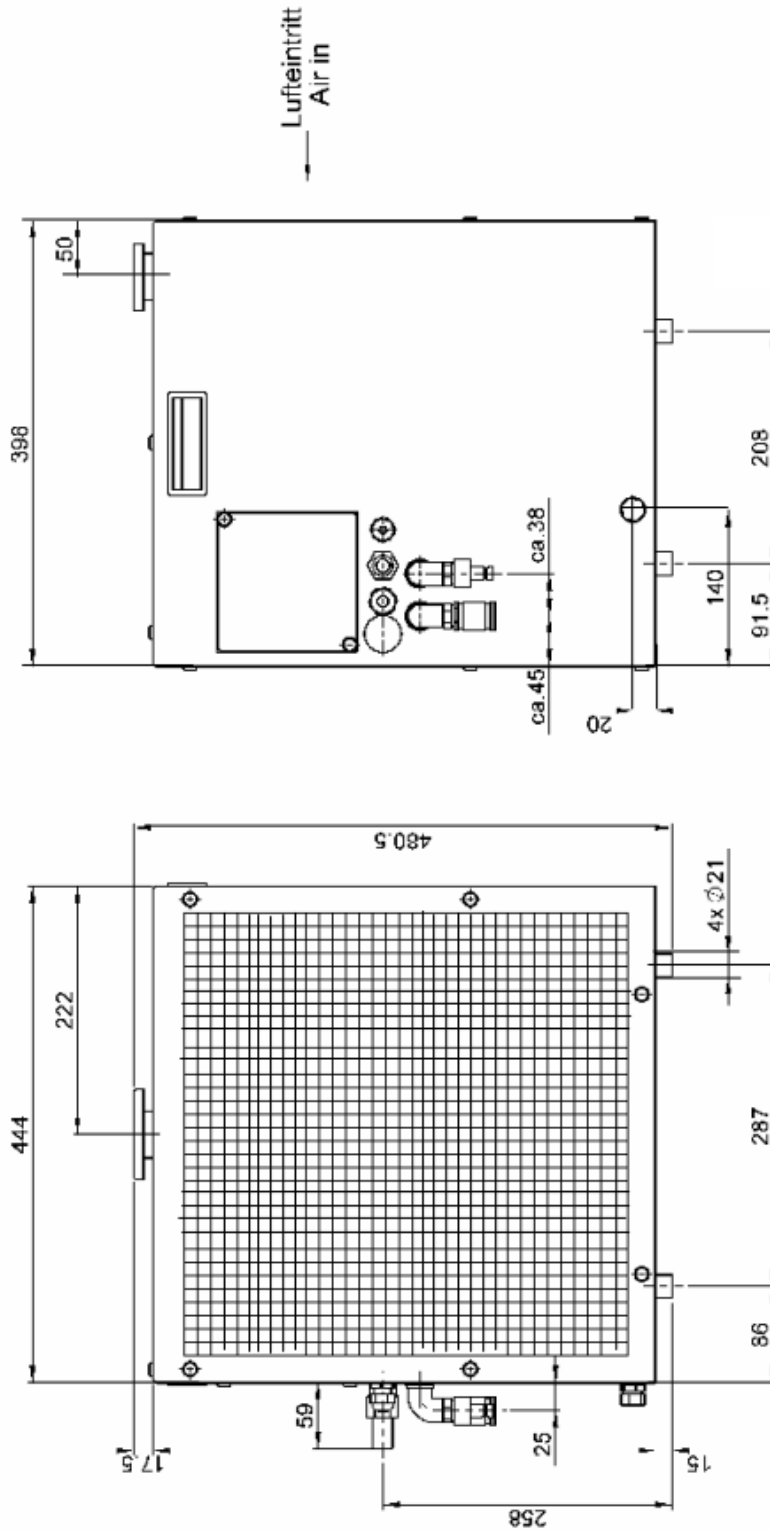

7 Circuit Diagrams

7.1 Electrical diagram

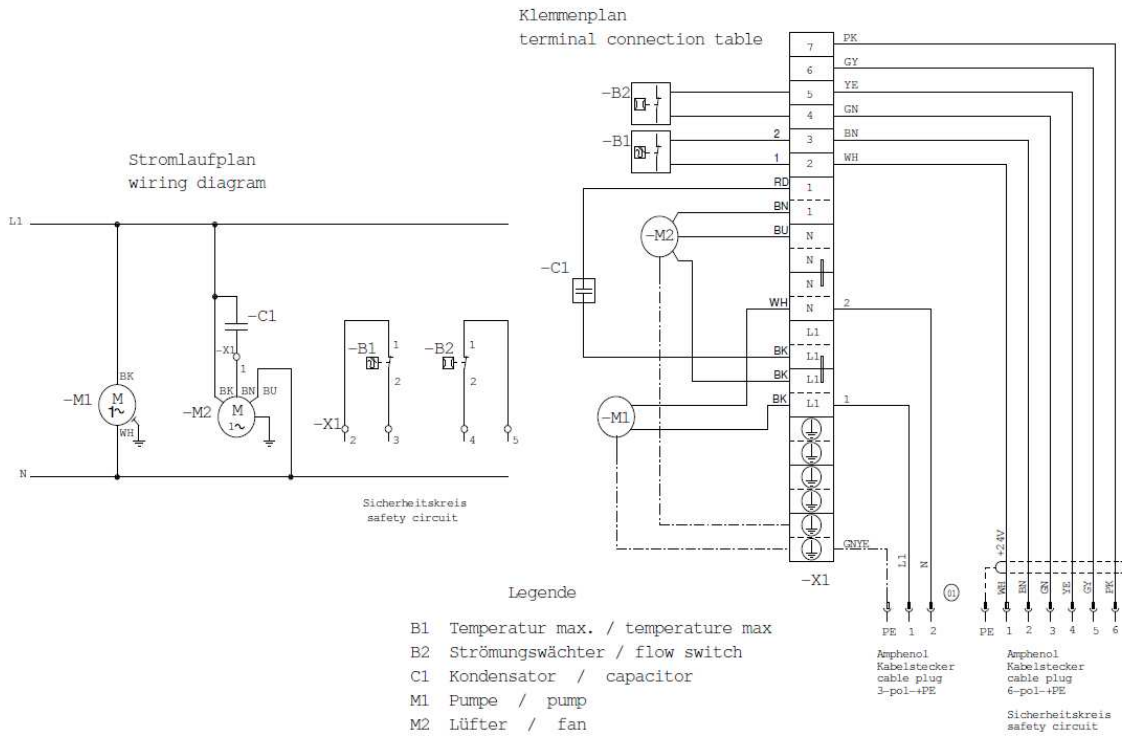

Attention: The cooler has to be fused when used as a stand alone unit with 4A, slow blow type. The default plug is a Cannon plug.

7.2 Block diagram

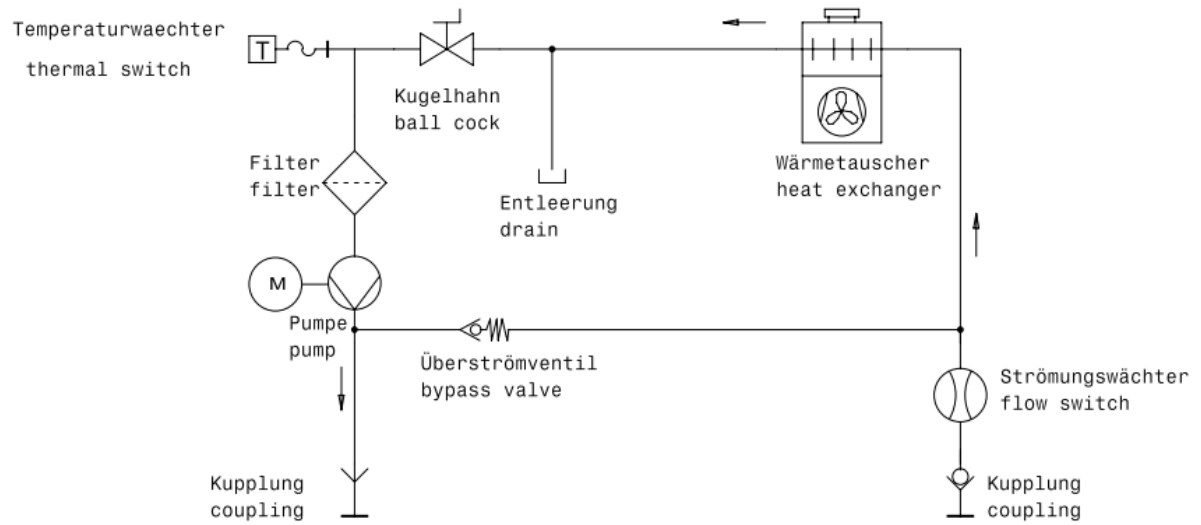

8 Declaration of conformity

EINBAUERKLÄRUNG FÜR UNVOLLSTÄNDIGE MASCHINE
DECLARATION OF INCORPORATION OF PARTLY COMPLETED MACHINERY
DÉCLARATION D'INCORPORATION DE QUASI-MACHINE



| | |
|--|---|
| Hersteller / Adresse: <i>Manufacturer / Address:</i> Fabricant / Adresse: | COMET AG Herrengasse 10 CH-3175 Flamatt |
| Produkte: <i>Products:</i> Produits: | Kühler Cooler Refrroidisseur |
| Bezeichnung / Bestell- Nr. <i>Type / Reference no.</i> Type / No. de référence | XRC-3001-WA 10008640 XRC-3001-WW 10008641 XRC-4501-OA 10008642 XRC-4501-OW 10008643 XRC-1001-WA 20033773 XRCA-3001-WA 20033337 XRCA-5001-OA 20033338 / 20032910 XRC-3012-WA 20049308 XRC-3012-WW 20049309 |

Wir erklären hiermit dass die oben aufgeführte unvollständige Maschine den grundlegenden Sicherheits- und Gesundheitsanforderungen der **Maschinenrichtlinie 2006/42/EG** Anhang I entspricht. Die speziellen Technischen Unterlagen gemäss Anhang VII Teil B wurden erstellt.

*We hereby declare that the partly completed machinery named above satisfies the relevant essential health and safety requirements set out in the Annex I of the **Machinery Directive 2006/42/EC**. The technical file according to the Annex VII part B is available.*

Nous déclarons que la quasi-machine mentionnées ci-dessus satisfait aux exigences essentielles de santé et de sécurité pertinentes énoncées à l'annexe I de la **directive machines 2006/42/CE**. Le dossier technique conforme à l'annexe VII, section B est disponible.

Angewandete Normen
Standards applied
Normes appliqués

DIN EN ISO 12100-1 (2004-04)
DIN EN ISO 12100-2 (2004-04)
DIN EN 60204-1 (2009-10)
DIN EN 349 (2008-09)

Datum: **Dezember 2010**
Date: **December 2010**
Date: **Décembre 2010**

Charles Flükiger
Manager Business Unit X-Ray

Dominique Corpataux
Manager R&D X-Ray Generators, BU X-Ray