

**Cam-operated
switching elements
for 160 A up to 300 A
S306, S307 Series**

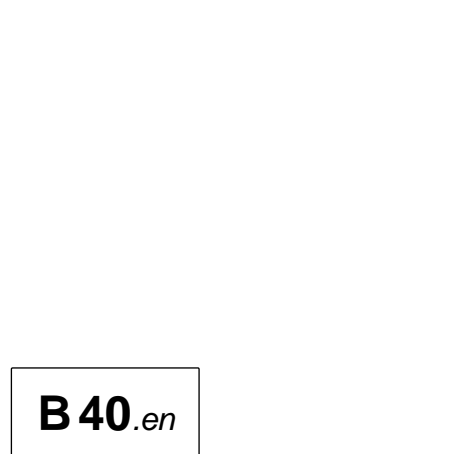
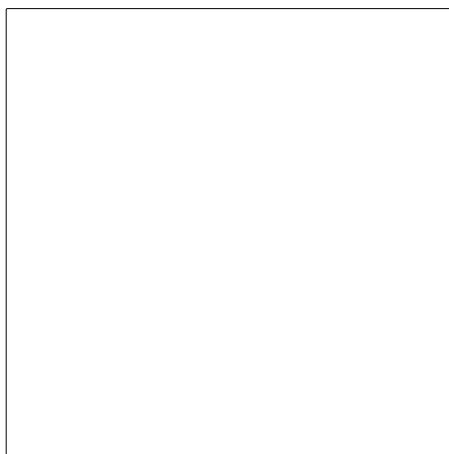
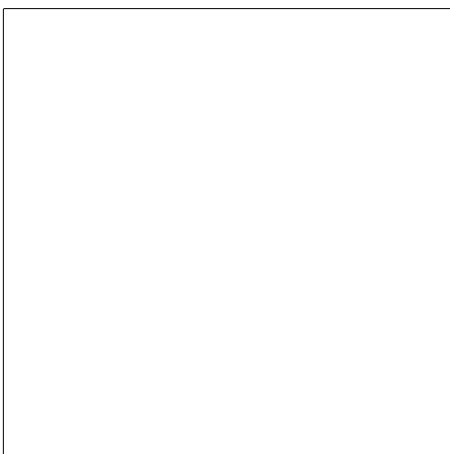
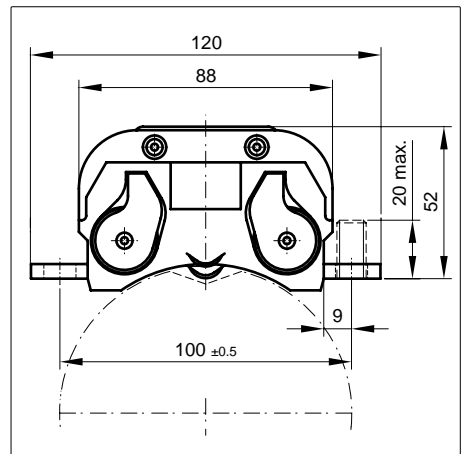
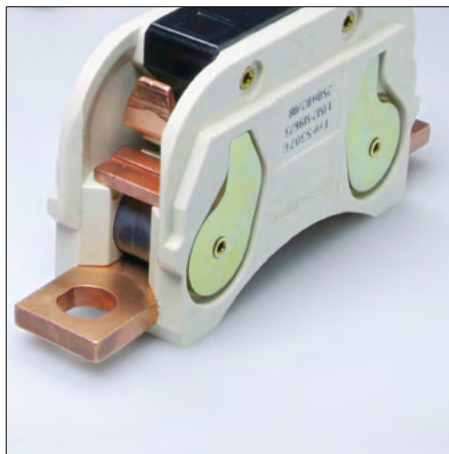
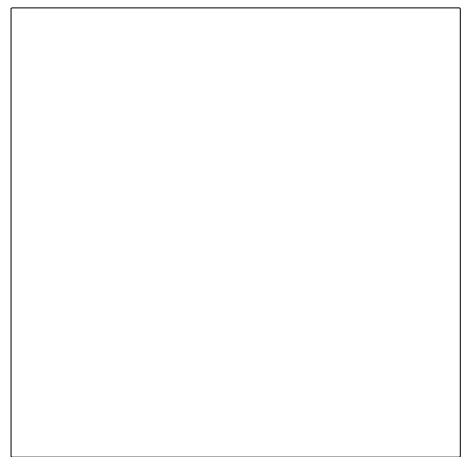

Cam-operated switching elements for 160 A up to 300 A

Series S306, S307

Cam-operated switching elements from Schaltbau are designed for DC and AC applications. Notwithstanding their compact design the series feature an extraordinary breaking capacity which is owed to the double-break contacts and long contact travel that make breaking the circuit a safe and reliable job.

Thus our series have proven themselves to be the reliable switching elements of master controllers, cam switch groups, cam contactors and various other switchgear for many years. They are much demanded for use in industrial trucks, rail vehicles, crane controls, bulk goods unloaders and emergency power supplies.

Application

Series S306, S307

DC applications: For switching voltages below 24 V and where only a low switching power is needed, switching elements without blowout and arc chamber will do. Versions with permanent-magnetic blowout are designed for voltages from 24 V upwards and a corresponding high switching power. When connected with the right polarity the permanent magnets which are embedded in the fixed contacts generate a magnetic field in which plasma is blown out. For use with voltages of over 40 V and switching powers with high plasma volume the optional arc chamber is recommended.

AC applications: Only cam-operated switching elements without magnetic blowout are suitable for use in AC circuits.

The S-shaped fixed contacts together with the contact bridge form an area where the arc is blown out of even with alternating current.

For use with higher switching power we recommend the optional arc chamber.

Cam-operated switching element, design

Series S306, S307

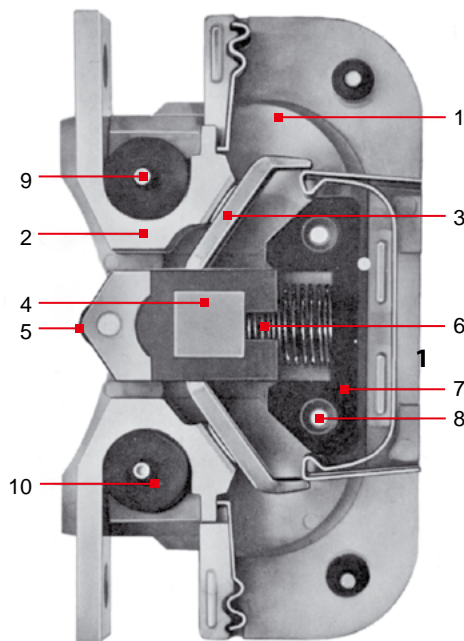

Section through a cam-operated switching element with mounted arc chamber

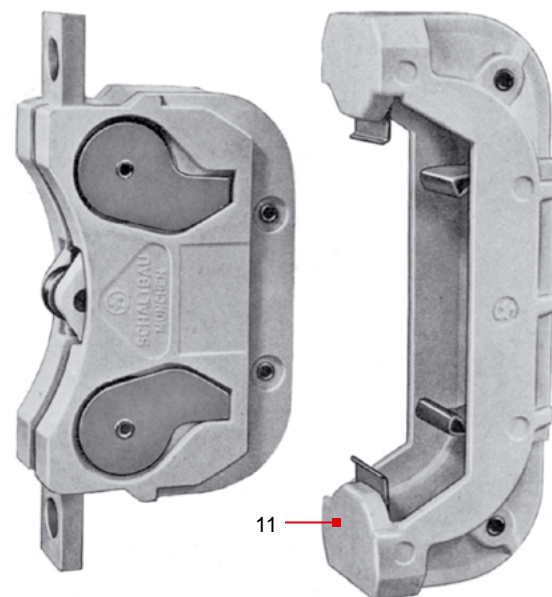

Cam-operated switching element S306 / S307 with disassembled arc chamber

Cam-operated switching elements from Schaltbau have a simple but effective design in accordance with the applicable standards (VDE, DIN).

The drive and contact mechanism is enclosed by the two shells 1 of the housing made of high-quality compression moulded plastic. The V-shaped contact bridge 3 is actuated by a smoothly gliding roller plunger 4 (roller 5). The necessary contact pressure is provided by a spring 6, which is supported by the spring bearing 7. The two hook-shaped fixed contacts 2 also serve as terminals for the connection of the conductor and as

kind of mounting brackets for mounting of the switching element. With DC versions, the permanent magnets 10 are fitted in the bend of the hook-shaped fixed contacts. The two shells of the housing are riveted together by means of the tubular rivets 8 and 9. The disassembled arc chamber is shown by 11.

Note: Observe the right polarity when connecting the cables to a cam-operated switching element with magnetic blowout. Make sure that the wire with the positive potential is connected to the terminal marked "+" (red label on spring bearing).

Ordering code

Series S306, S307

Series S306 Example **S306 A**

Series	S306 Cam-operated switching element	
Version	A	200 A, without blowout, colour marking: green
	C	200 A, with blowout, colour marking: green
	K	160 A, without blowout, colour marking: black
	M	160 A, with blowout, colour marking: black

Series S307 Example **S307 G**

Series	S307 Cam-operated switching element	
Version	A	300 A, without blowout, colour marking: green
	C	300 A, with blowout, colour marking: green
	E	250 A, without blowout, colour marking: black
	G	250 A, with blowout, colour marking: black
	G / N	250 A, with blowout, colour marking: black with key and keyway for arc chute LK-S307-DC
	C / N	300 A, with blowout, colour marking: green with key and keyway for arc chute LK-S307-DC

Arc chamber: Arc chambers the cam-operated switching elements can be fitted with must be ordered separately.

LK-S306	Arc chamber for cam-operated switching element S306
LK-S307	Arc chamber for cam-operated switching element S307
LK-S307-DC	Arc chute especially for cam-operated switching element S307 G / N or S307 C / N with key and keyway for mounting with right polarity, suitable for high voltages

Cam-operated switching elements are often needed as spare parts for Schaltbau cam contactors. So if you need a spare part please also specify the contactor when you order the switching element.

Stock items:

S306 C	200 A, with blowout, colour marking: green
S306 M	160 A, with blowout, colour marking: black
S307 C	300 A, with blowout, colour marking: green
S307 G	250 A, with blowout, colour marking: black

Special design

If you need a special design do not hesitate to contact us. Maybe the type of switching element you are looking for is among our many special designs. If not, we can also supply customized designs. In this case, however, minimum order quantities apply.

Dimension diagrams, Circuit diagram

Series S306, S307

Dimension diagram with arc chamber:

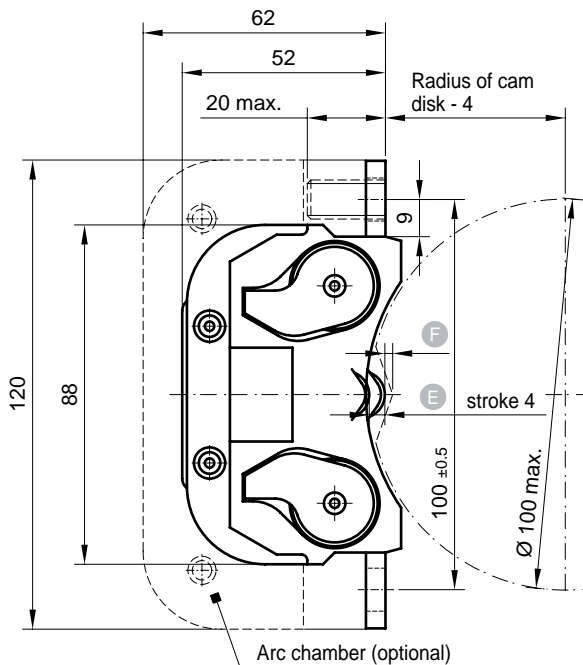

Dimension diagram without arc chamber:

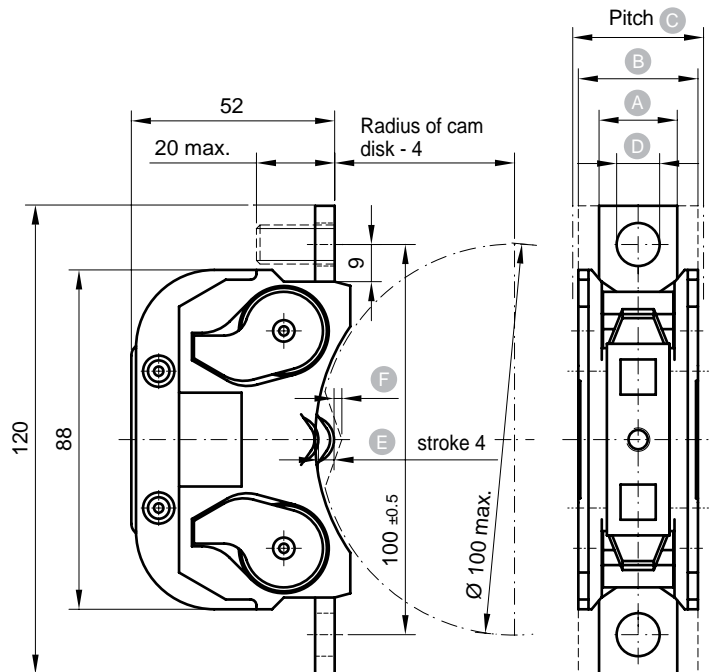

Series	Dimensions in mm				Working stroke	Free stroke
	A	B	C*	D		
S306	16	27	28	Ø9	4 mm	2 mm
S307	20	31	32	Ø11	4 mm	2 mm

Circuit diagram:



* Recommended pitch to facilitate ganging

Specifications, Versions

Series S306, S307

Specifications	
Conv. thermal current I_{th}	See following table »Versions«
Material	Insulating parts: compression moulded plastics Contact pieces: silver plated copper Contact: silver tin oxide (AgSnO ₂)
Mechanical endurance	5 million operating cycles min.
Pollution degree (IEC 60947-1)	PD3
Rated insulation voltage U_i	1,000 V When mounted individually, with actuator made from plastic and normal contact gap
	400 V When mounted in series with minimum clearance 28 and 32 mm resp.
Dimensions (L x D x H)	S306 62 x 27 x 120 mm
	S307 62 x 31 x 120 mm
Weight	S306 A, S306 K 0.23 kg
	S306 C, S306 M 0.28 kg
	S307 A, S307 E 0.27 kg
	S307 C, S307 G 0.33 kg
	S307 C /N, S307 G /N 0.33 kg
Temperature range	-25°C ... +70 °C

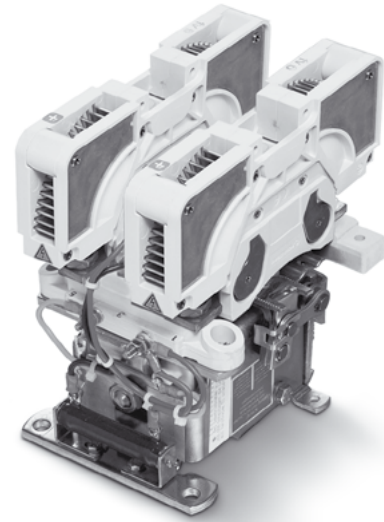



Photo: Schaltbau GmbH

C155 P Series contactor: Fitted with cam-operated switching element S307 C /N and arc chute LK-S307-DC.

Versions

Series*	Conv. thermal current I_{th}	Contact pressure	Permanent magnetic blowout	Actuating force at plunger	Colour marking**	Terminals	Arc chamber (optional)
S306 K	160 A	3.5 N	none	7.0 ... 8.0 N	black	Ø 9.0 mm for M8 screw Torque 3.0 ... 6.0 Nm	LK-S306
S306 M			existent				
S306 A	200 A	5.5 N	none	11.0 ... 13.0 N	green		
S306 C			existent				
S307 E	250 A	5.5 N	none	11.0 ... 13.0 N	black	Ø 11.0 mm for M10 screw Torque 5.0 ... 10.0 Nm	LK-S307
S307 G			existent				
S307 A	300 A	10.0 N	none	20.0 ... 30.0 N	green		
S307 C			existent				
S307 G /N	250 A	5.5 N	existent	11.0 ... 13.0 N	black	Ø 11.0 mm for M10 screw Torque 5.0 ... 10.0 Nm	LK-S307-DC
S307 C /N	300 A	10.0 N	existent	20.0 ... 30.0 N	green		

* Cam-operated switching elements are delivered without the optional arc chamber. So if your application requires the use of an arc chamber, it has to be ordered separately. (for ordering code refer to column Arc chamber).

** In addition to the type label the colour marking of the spring bearing helps to identify the type of switching element that is used.

Inspection and maintenance

Series S306, S307

The mechanical parts of the cam-operated switching elements are basically free of wear and tear under normal operation. So maintenance work like to grease occasionally is not necessary. An occasional inspection of the state of the contacts is, therefore, all that is needed.

Do not smooth the contacts with a file or sand paper only to make them look nicer. Black contacts are the result of the oxidation of silver. AgO, however, is in itself highly conductive and need not be removed at all.

Breaking capacity

Series S306, S307

The breaking capacity of a switching element is a relative value which is influenced by a number of interactive factors like the kind of current (AC or DC), voltage, amperage, switching speed, frequency of operating cycles and design life. So if the maximum is required for one of those conditions, it means that all other conditions must be reduced correspondingly. The exact values can only be determined in several test series.

As a guideline for choosing the right type of switching element that suits your application the below diagrams show the maximum breaking capacity of the switching element.

For use under normal operating conditions these values are to be reduced for reasons of safety and in order to enhance the electrical endurance of the switching element. Based on our experience, it is, therefore, recommendable to limit the

actual breaking capacity to 20% up to 60% of the maximum breaking capacity as shown in the diagrams. The value of the maximum breaking capacity reflects the capacity at which the arc is still being extinguished.

The making capacity depends on both the welding strength of the contact material and the speed of actuation (bouncing). With magnetic actuation the making capacity is between 1000 A and 2000 A depending on the type of the switching element used. Due to the fact that the switching voltage has practically no bearing on the welding strength, this value covers the entire scope of application.

DC applications:

Maximum breaking capacity of cam-operated switching elements S306 and S307 with permanent magnetic blowout and arc chamber.

With switching voltages from 400 V upwards the cam-operated switching element S307 must be used with arc chute LK-S307-DC

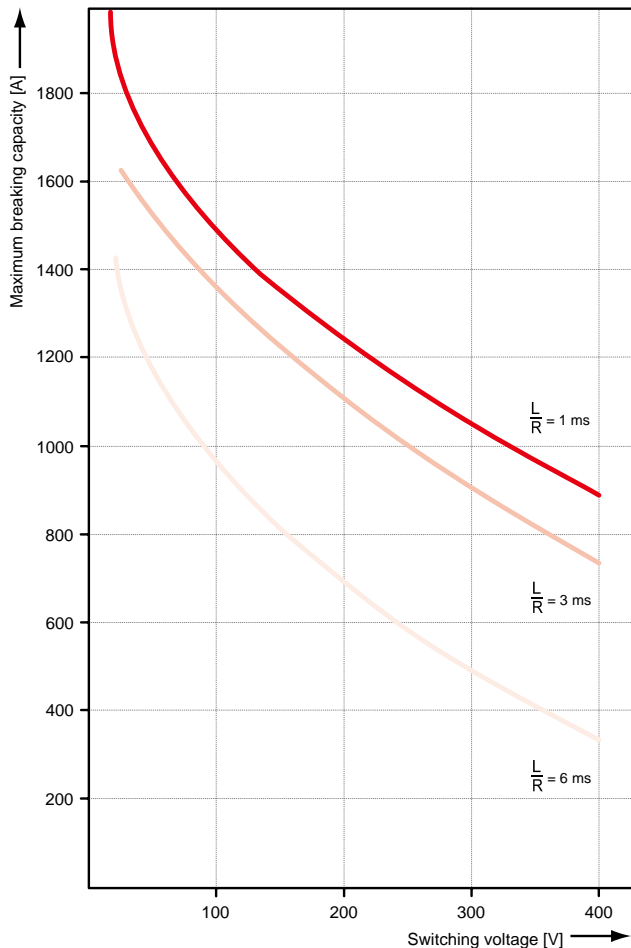

AC applications:

Maximum breaking capacity of cam-operated switching elements S306 and S307 without blowout, with arc chamber

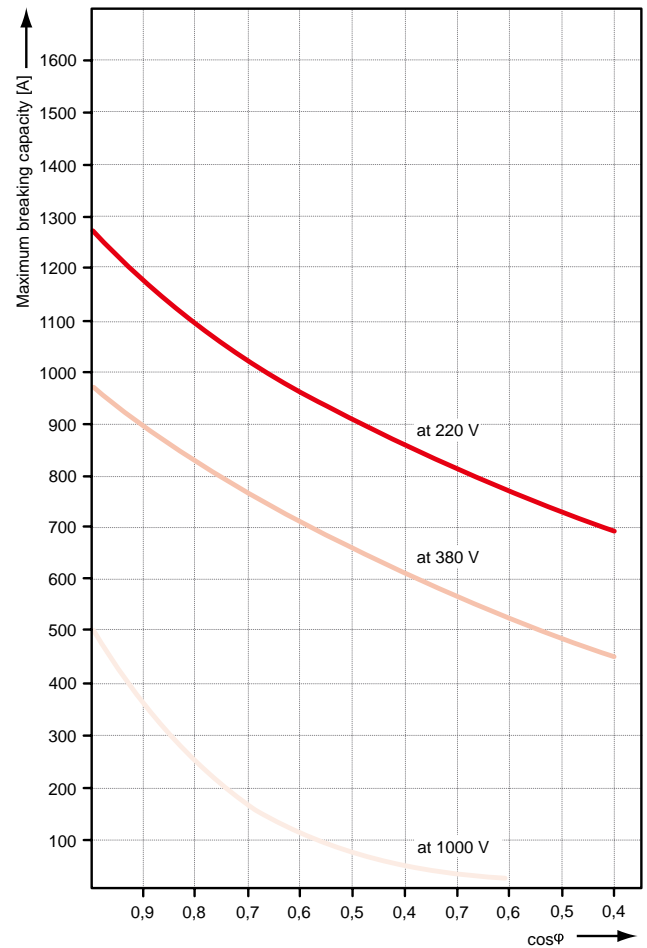

Temperature rise

Series S306, S307

The below curves show the temperature rise of switching elements with different current-carrying capacities. The insulating materials used for our cam-operated switching elements allow for overtemperatures of 90 K at an ambient temperature of 50°C. This results in an upper limiting temperature of 140°C. The temperature rise depends on the cross-sectional area and material of the live parts, the contact pressure, as well as the size of the surface and kind of the contact finish. So make sure to reduce the temperature by using cables with an appropriate wire gauge.

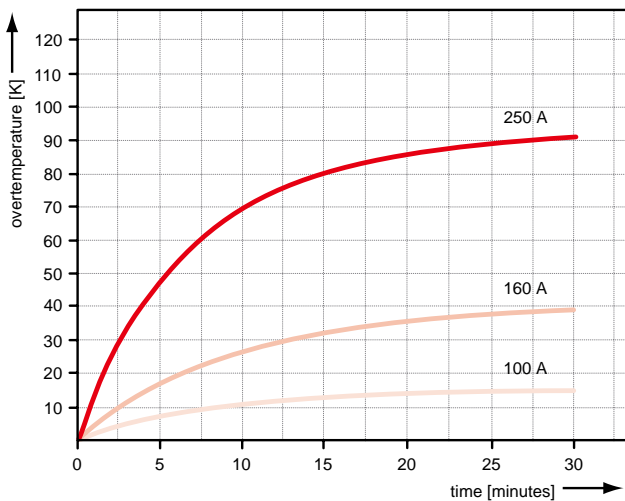

Temperature rise of switching element S306 K and S306 M resp. (wire cross section area 35 mm²)
 The permissible overtemperature is only reached at an amperage of over 160 A. The permissible conventional thermal current is 160 A (contact pressure 3.5 N).

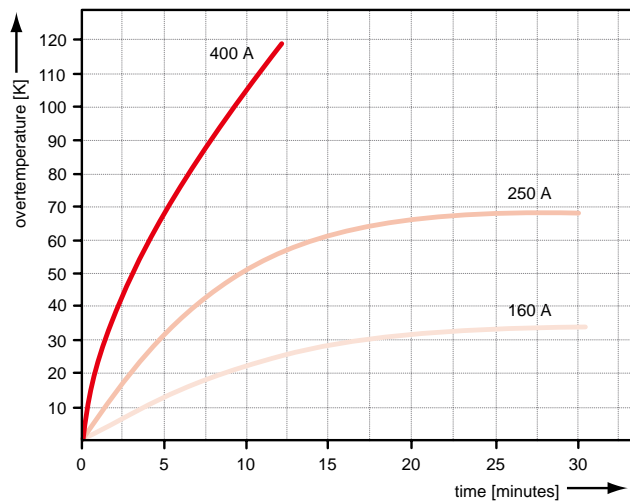

Temperature rise of switching element S307 E and S307 G resp. (wire cross section area 70 mm²)
 The permissible conventional thermal current for this series is 250 A (contact pressure 5.5 N).

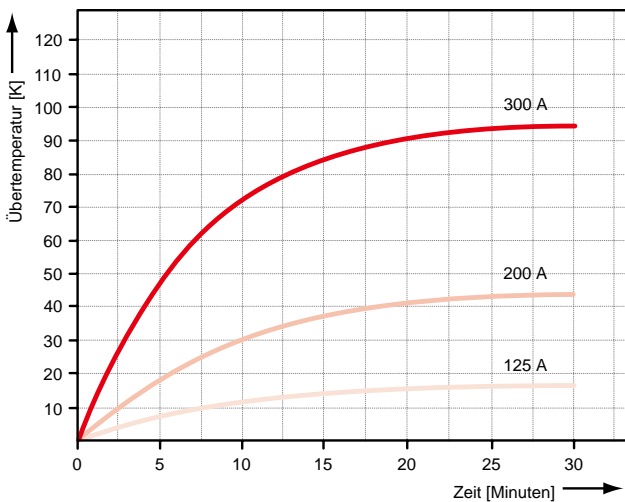

Temperature rise of switching element S306 A and S306 C resp. (wire cross section area 50 mm²)
 The permissible conventional thermal current for this series is 200 A (contact pressure 5.5 N).

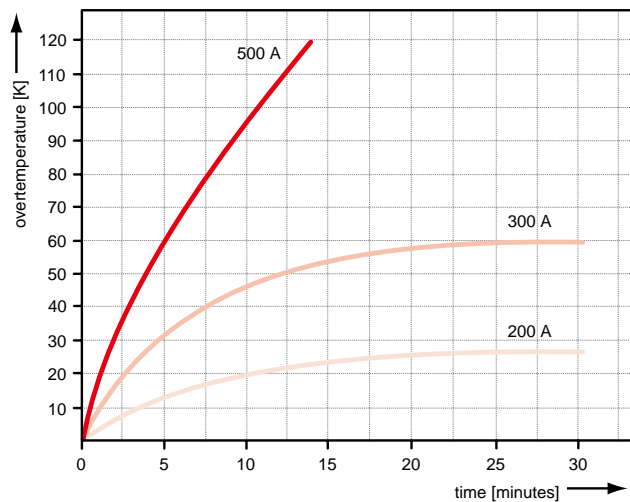

Temperature rise of switching element S307 A and S307 C resp. (wire cross section area 95 mm²)
 The permissible conventional thermal current for this series is 300 A (contact pressure 10 N).

Notes

Two columns of horizontal dotted lines for writing notes.



Schaltbau GmbH manufactures in compliance with RoHS.



The production facilities of Schaltbau GmbH have been IRIS certified since 2008.



Certified to DIN EN ISO 14001 since 2002. For the most recent certificate visit our website.



Certified to DIN EN ISO 9001 since 1994. For the most recent certificate visit our website.

Electrical Components and Systems for Railway Engineering and Industrial Applications

Connectors

- Connectors manufactured to industry standards
- Connectors to suit the special requirements of communications engineering (MIL connectors)
- Charging connectors for battery-powered machines and systems
- Connectors for railway engineering, including UIC connectors
- Special connectors to suit customer requirements

Snap-action switches

- Snap-action switches with positive opening operation
- Snap-action switches with self-cleaning contacts
- Enabling switches
- Special switches to suit customer requirements

Contactors

- Single and multi-pole DC contactors
- High-voltage AC/DC contactors
- Contactors for battery powered vehicles and power supplies
- Contactors for railway applications
- Terminal bolts and fuse holders
- DC emergency stop switches
- Special contactors to suit customer requirements

Control devices

- Master controllers and reversers for railway applications
- Toggle switch devices
- Handles and foot switches for railway applications (dead-man equipment)
- Switching elements with high breaking capacity
- Emergency brake handles
- Signal devices

Transportation system equipment

- Power supplies for passenger coaches (electric equipment)
- Battery chargers for locomotives and passenger coaches
- High-voltage equipment for single and multi-phase operation
- Heating devices and heating controls
- Design and engineering services for high-voltage equipment
- Special equipment to suit customer requirements

Schaltbau GmbH

Hollerithstrasse 5
81829 Munich
Germany

Phone +49 89 9 30 05-0
Fax +49 89 9 30 05-350
e-Mail contact@schaltbau.de
Internet www.schaltbau.de

with compliments: